

PHILIPS

Data handbook



Electronic
components
and materials

Semiconductors and integrated circuits

Part 1b October 1975

Small signal germanium diodes

Small signal silicon diodes

Special diodes

Voltage regulator diodes

Voltage reference diodes

Tuner diodes

SEMICONDUCTORS AND INTEGRATED CIRCUITS

Part 1b

October 1975

General

Germanium small signal diodes (point contact)

(gold bonded)

Silicon small signal diodes (alloyed)

(whiskerless)

special diodes

voltage regulator diodes

voltage reference diodes

tuner diodes

Index

DATA HANDBOOK SYSTEM

Our Data Handbook System is a comprehensive source of information on electronic components, subassemblies and materials; it is made up of three series of handbooks each comprising several parts.

ELECTRON TUBES	BLUE
SEMICONDUCTORS AND INTEGRATED CIRCUITS	RED
COMPONENTS AND MATERIALS	GREEN

The several parts contain all pertinent data available at the time of publication, and each is revised and reissued periodically.

Where ratings or specifications differ from those published in the preceding edition they are pointed out by arrows. Where application information is given it is advisory and does not form part of the product specification.

If you need confirmation that the published data about any of our products are the latest available, please contact our representative. He is at your service and will be glad to answer your inquiries.

This information is furnished for guidance, and with no guarantee as to its accuracy or completeness; its publication conveys no licence under any patent or other right, nor does the publisher assume liability for any consequence of its use; specifications and availability of goods mentioned in it are subject to change without notice; it is not to be reproduced in any way, in whole or in part without the written consent of the publisher.

ELECTRON TUBES (BLUE SERIES)

This series consists of the following parts, issued on the dates indicated.

- | | | | |
|----------------|---|----------------------------------|---------------------|
| Part 1a | Transmitting tubes for communications
and Tubes for r.f. heating | Types PB2/500 ÷ TBW15/125 | April 1973 |
| Part 1b | Transmitting tubes for communication
Tubes for r.f. heating
Amplifier circuit assemblies | | August 1974 |
| Part 2 | Microwave products | | October 1974 |
| | Communication magnetrons | Diodes | |
| | Magnetrons for microwave heating | Triodes | |
| | Klystrons | T-R Switches | |
| | Travelling-wave tubes | Microwave Semiconductor devices | |
| | | Isolators Circulators | |
| Part 3 | Special Quality tubes;
Miscellaneous devices | | January 1975 |
| Part 4 | Receiving tubes | | March 1975 |
| Part 5a | Cathode-ray tubes | | April 1975 |
| Part 5b | Camera tubes; Image intensifier tubes | | May 1975 |
| Part 6 | Products for nuclear technology
Photodiodes | | July 1975 |
| | | Neutron tubes | |
| | Channel electron multipliers | | |
| | Geiger-Mueller tubes | | |
| | N.B. Photomultiplier tubes and Photo diodes will be issued in Part 9 | | |
| Part 7 | Gas-filled tubes | | August 1975 |
| | Voltage stabilizing and reference tube | Thyratrons | |
| | Counter, selector, and indicator tubes | Ignitrons | |
| | Trigger tubes | Industrial rectifying tubes | |
| | Switching diodes | High-voltage rectifying tubes | |
| Part 8 | TV Picture tubes | | October 1975 |

SEMICONDUCTORS AND INTEGRATED CIRCUITS (RED SERIES)

This series consists of the following parts, issued on the dates indicated.

Part 1a	Rectifier diodes and thyristors		June 1974
	Rectifier diodes	Thyristors, diacs, triacs	
	Voltage regulator diodes (> 1, 5 W)	Rectifier stacks	
	Transient suppressor diodes		
Part 1b	Diodes		October 1975
	Small signal germanium diodes	Voltage regulator diodes (< 1, 5 W)	
	Small signal silicon diodes	Voltage reference diodes	
	Special diodes	Tuner diodes	
Part 2	Low frequency transistors		July 1974
Part 3	High frequency and switching transistors		October 1974
Part 4a	Special semiconductors		November 1974
	Transmitting transistors	Dual transistors	
	Microwave devices	Microminiature devices for thick- and thin-film circuits	
	Field-effect transistors		
Part 4b	Devices for opto-electronics		December 1974
	Photosensitive diodes and transistors	Infra-red sensitive devices	
	Light emitting diodes	Photoconductive devices	
	Photocouplers		
Part 5	Linear integrated circuits		March 1975
Part 6	Digital integrated circuits		April 1974
	DTL (FC family)	MOS (FD family)	
	CML (GX family)	MOS (FE family)	

COMPONENTS AND MATERIALS (GREEN SERIES)

These series consists of the following parts, issued on the dates indicated.

Part 1 Functional units, Input/output devices,

Electro-mechanical components, Peripheral devices June 1974

High noise immunity logic FZ/30-Series	Circuit blocks 90-Series
Circuit blocks 40-Series and CSA70	Input/output devices
Counter modules 50-Series	Electro-mechanical components
Norbits 60-Series, 61-Series	Peripheral devices

Part 2a Resistors

September 1974

Fixed resistors	Negative temperature coefficient thermistors (NTC)
Variable resistors	Positive temperature coefficient thermistors (PTC)
Voltage dependent resistors (VDR)	Test switches
Light dependent resistors (LDR)	

Part 2b Capacitors

November 1974

Electrolytic and solid capacitors	Ceramic capacitors
Paper capacitors and film capacitors	Variable capacitors

Part 3 Radio, Audio, Television

February 1975

FM tuners	Components for black and white television
Loudspeakers	Components for colour television *)
Television tuners, aerial input assemblies	

Part 4a Soft ferrites

April 1975

Ferrites for radio, audio and television	Ferroxcube potcores and square cores
Beads and chokes	Ferroxcube transformer cores

Part 4b Piezoelectric ceramics, Permanent magnet materials May 1975

Part 5 Ferrite core memory products

July 1975

Ferroxcube memory cores	Core memory systems
Matrix planes and stacks	

Part 6 Electric motors and accessories

September 1975

Small synchronous motors	Miniature direct current motors
Stepper motors	

Part 7 Circuit blocks

September 1971

Circuit blocks 100 kHz-Series	Circuit blocks for ferrite core memory drive
Circuit blocks 1-Series	
Circuit blocks 10-Series	

Part 8 Variable mains transformers

July 1975

*) Deflection assemblies for camera tubes are now included in handbook series "Electron tubes", Part 5b.



General

Type designation

Rating systems

Letter symbols

Colour codes

Packing

Mounting and soldering

PRO ELECTRON TYPE DESIGNATION CODE
FOR SEMICONDUCTOR DEVICES

This type designation code applies to discrete devices and to multiple devices ¹⁾

The type designation consists of:

TWO LETTERS FOLLOWED BY A SERIAL NUMBER

The first letter gives an indication of the material

- A Material with a band gap of 0.6 to 1.0 eV, such as germanium
- B Material with a band gap of 1.0 to 1.3 eV, such as silicon
- C Material with a band gap of 1.3 eV and more, such as gallium arsenide
- D Material with a band gap of less than 0.6 eV, such as indium antimonide
- R Compound material as employed in Hall generators and photoconductive cells

¹⁾ A multiple device is defined as a combination of similar or dissimilar active devices, contained in a common encapsulation that cannot be dismantled, and of which all electrodes of the individual devices are accessible from the outside.

Multiples of similar devices as well as multiples consisting of a main device and an auxiliary device are designated according to the code for discrete devices described above.

Multiples of dissimilar devices of other nature are designated by the second letter G.

TYPE DESIGNATION

The second letter indicates primarily the main application respectively main application and construction if a further differentiation is essential

- A Detection diode, switching diode, mixer diode
- B Variable capacitance diode
- C Transistor for a.f. applications ($R_{th\ j-mb} > 15\ ^\circ C/W$)
- D Power transistor for a.f. applications ($R_{th\ j-mb} \leq 15\ ^\circ C/W$)
- E Tunnel diode
- F Transistor for h.f. applications ($R_{th\ j-mb} > 15\ ^\circ C/W$)
- G Multiple of dissimilar devices (see note on page 1); Miscellaneous
- H Magnetic sensitive diode; Field probe
- K Hall generator in an open magnetic circuit, e.g. magnetogram or signal probe
- L Power transistor for h.f. applications ($R_{th\ j-mb} \leq 15\ ^\circ C/W$)
- M Hall generator in a closed electrically energised magnetic circuit, e.g. Hall modulator or multiplier
- N Photocoupler
- P Radiation sensitive device ¹⁾
- Q Radiation generating device
- R Electrically triggered controlling and switching device having a break-down characteristic ($R_{th\ j-mb} > 15\ ^\circ C/W$)
- S Transistor for switching applications ($R_{th\ j-mb} > 15\ ^\circ C/W$)
- T Electrically, or by means of light, triggered controlling and switching power device having a breakdown characteristic ($R_{th\ j-mb} \leq 15\ ^\circ C/W$)¹⁾
- U Power transistor for switching applications ($R_{th\ j-mb} \leq 15\ ^\circ C/W$)
- X Multiplier diode, e.g. varactor, step recovery diode
- Y Rectifying diode, booster diode, efficiency diode ¹⁾
- Z Voltage reference or voltage regulator diode ¹⁾

¹⁾ For the type designation of a range see page 4.

The serial number consists of:

Three figures for semiconductor devices designed primarily for use in domestic equipment

One letter and two figures for semiconductor devices designed primarily for use in professional equipment

VERSION LETTER

A version letter can be used, for instance, for a diode with up-rated voltage, for a sub-division of a transistor type in different gain ranges, a low noise version of an existing transistor and for a diode, transistor, or thyristor with minor mechanical differences, such as finish of the leads, length of the leads etc. The letters never have a fixed meaning, the only exception being the letter R.

TYPE DESIGNATION FOR A RANGE OF SEMICONDUCTOR DEVICES

The type designation of a range of variants of:

- a) voltage reference or voltage regulator diodes (second letter Z)
- b) rectifier diodes (second letter Y)
- c) thyristors (second letter T)
- d) radiation detectors

distinctly belonging to one basic type may be qualified by a suffix part which is clearly separated from the basic part by a hyphen (-)

THE BASIC PART being the same for the whole range, is in accordance with the designation code for discrete devices.

THE SUFFIX PART consists of:

- a) for voltage reference or voltage regulator diodes

one letter followed by the typical working voltage and where appropriate the letter R ¹⁾
The first letter indicates the nominal tolerance of the working voltage in %.

A	1%
B	2%
C	5%
D	10%
E	15%

The typical working voltage is related to the nominal current rating for the whole range. The letter V is used to denote the decimal comma when this occurs.

- b) for rectifier diodes

a number and where appropriate the letter R ¹⁾

The number generally indicates the maximum repetitive peak reverse voltage. For controlled avalanche types it indicates the maximum crest working reverse voltage.

- c) for thyristors

a number and where appropriate the letter R ¹⁾

The number generally indicates either the maximum repetitive peak reverse voltage or the maximum repetitive peak off-state voltage, whichever is lower.

For controlled avalanche types it indicates the maximum crest working reverse voltage.

- d) for radiation detectors

a figure giving the depth of the depletion layer in μm and where appropriate a version letter if there are differences in resolution.

¹⁾ The letter R indicates reverse polarity (anode to stud). The normal polarity (cathode to stud) and symmetrical versions are not specially indicated.

RATING SYSTEMS

ACCORDING TO I.E.C. PUBLICATION 134

1. DEFINITIONS OF TERMS USED

- 1.1 Electronic device. An electronic tube or valve, transistor or other semiconductor device.

Note: This definition excludes inductors, capacitors, resistors and similar components.

- 1.2 Characteristic. A characteristic is an inherent and measurable property of a device. Such a property may be electrical, mechanical, thermal, hydraulic, electro-magnetic, or nuclear, and can be expressed as a value for stated or recognized conditions. A characteristic may also be a set of related values, usually shown in graphical form.

- 1.3 Bogey electronic device. An electronic device whose characteristics have the published nominal values for the type. A bogey electronic device for any particular application can be obtained by considering only those characteristics which are directly related to the application.

- 1.4 Rating. A value which establishes either a limiting capability or a limiting condition for an electronic device. It is determined for specified values of environment and operation, and may be stated in any suitable terms.

Note: Limiting conditions may be either maxima or minima.

- 1.5 Rating system. The set of principles upon which ratings are established and which determine their interpretation.

Note: The rating system indicates the division of responsibility between the device manufacturer and the circuit designer, with the object of ensuring that the working conditions do not exceed the ratings.

2. ABSOLUTE MAXIMUM RATING SYSTEM

Absolute maximum ratings are limiting values of operating and environmental conditions applicable to any electronic device of a specified type as defined by its published data, which should not be exceeded under the worst probable conditions.

These values are chosen by the device manufacturer to provide acceptable serviceability of the device, taking no responsibility for equipment variations, environmental variations, and the effects of changes in operating conditions due to variations in the characteristics of the device under consideration and of all other electronic devices in the equipment.

p.t.o.

The equipment manufacturer should design so that, initially and through-out life, no absolute maximum value for the intended service is exceeded with any device under the worst probable operating conditions with respect to supply voltage variation, equipment component variation, equipment control adjustment, load variations, signal variation, environmental conditions, and variations in characteristics of the device under consideration and of all other electronic devices in the equipment.

3. DESIGN MAXIMUM RATING SYSTEM

Design maximum ratings are limiting values of operating and environmental conditions applicable to a bogey electronic device of a specified type as defined by its published data, and should not be exceeded under the worst probable conditions.

These values are chosen by the device manufacturer to provide acceptable serviceability of the device, taking responsibility for the effects of changes in operating conditions due to variations in the characteristics of the electronic device under consideration.

The equipment manufacturer should design so that, initially and through-out life, no design maximum value for the intended service is exceeded with a bogey device under the worst probable operating conditions with respect to supply voltage variation, equipment component variation, variation in characteristics of all other devices in the equipment, equipment control adjustment, load variation, signal variation and environmental conditions.

4. DESIGN CENTRE RATING SYSTEM

Design centre ratings are limiting values of operating and environmental conditions applicable to a bogey electronic device of a specified type as defined by its published data, and should not be exceeded under normal conditions.

These values are chosen by the device manufacturer to provide acceptable serviceability of the device in average applications, taking responsibility for normal changes in operating conditions due to rated supply voltage variation, equipment component variation, equipment control adjustment, load variation, signal variation, environmental conditions, and variations in the characteristics of all electronic devices.

The equipment manufacturer should design so that, initially, no design centre value for the intended service is exceeded with a bogey electronic device in equipment operating at the stated normal supply voltage.

NOTE

It is common use to apply the Absolute Maximum System in semiconductor published data.

LETTER SYMBOLS FOR TRANSISTORS AND SIGNAL DIODES

based on IEC Publication 148

LETTER SYMBOLS FOR CURRENTS, VOLTAGES AND POWERS

Basic letters

The basic letters to be used are:

I, i = current
 V, v = voltage
 P, p = power.

Lower-case basic letters shall be used for the representation of instantaneous values which vary with time.

In all other instances upper-case basic letters shall be used.

Subscripts

A, a	Anode terminal
(AV), (av)	Average value
B, b	Base terminal, for MOS devices: Substrate
(BR)	Breakdown
C, c	Collector terminal
D, d	Drain terminal
E, e	Emitter terminal
F, f	Forward
G, g	Gate terminal
K, k	Cathode terminal
M, m	Peak value
O, o	As third subscript: The terminal not mentioned is open circuited
R, r	As first subscript: Reverse. As second subscript: Repetitive. As third subscript: With a specified resistance between the terminal not mentioned and the reference terminal.
(RMS), (rms)	R. M. S. value
S, s	As first or second subscript: Source terminal (for FETS only)
	As second subscript: Non-repetitive (not for FETS)
	As third subscript: Short circuit between the terminal not mentioned and the reference terminal
X, x	Specified circuit
Z, z	Replaces R to indicate the actual working voltage, current or power of voltage reference and voltage regulator diodes.

Note: No additional subscript is used for d. c. values.

Upper-case subscripts shall be used for the indication of:

- a) continuous (d. c.) values (without signal)
Example I_B
- b) instantaneous total values
Example i_B
- c) average total values
Example $I_{B(AV)}$
- d) peak total values
Example I_{BM}
- e) root-mean-square total values
Example $I_{B(RMS)}$

Lower-case subscripts shall be used for the indication of values applying to the varying component alone:

- a) instantaneous values
Example i_b
- b) root-mean-square values
Example $I_{b(rms)}$
- c) peak values
Example I_{bm}
- d) average values
Example $I_{b(av)}$

Note: If more than one subscript is used, subscript for which both styles exist shall either be all upper-case or all lower-case.

Additional rules for subscripts

Subscripts for currents

Transistors: If it is necessary to indicate the terminal carrying the current, this should be done by the first subscript (conventional current flow from the external circuit into the terminal is positive).

Examples: I_B, I_B, i_b, I_{bm}

Diodes: To indicate a forward current (conventional current flow into the anode terminal) the subscript F or f should be used; for a reverse current (conventional current flow out of the anode terminal) the subscript R or r should be used.

Examples: $I_F, I_R, i_F, I_{f(rms)}$

Subscripts for voltages

Transistors: If it is necessary to indicate the points between which a voltage is measured, this should be done by the first two subscripts. The first subscript indicates the terminal at which the voltage is measured and the second the reference terminal or the circuit node. Where there is no possibility of confusion, the second subscript may be omitted.

Examples: V_{BE} , V_{BE} , v_{be} , V_{bem}

Diodes: To indicate a forward voltage (anode positive with respect to cathode), the subscript F or f should be used; for a reverse voltage (anode negative with respect to cathode) the subscript R or r should be used.

Examples: V_F , V_R , v_F , V_{rm}

Subscripts for supply voltages or supply currents

Supply voltages or supply currents shall be indicated by repeating the appropriate terminal subscript.

Examples: V_{CC} , I_{EE}

Note: If it is necessary to indicate a reference terminal, this should be done by a third subscript

Example: V_{CCE}

Subscripts for devices having more than one terminal of the same kind

If a device has more than one terminal of the same kind, the subscript is formed by the appropriate letter for the terminal followed by a number; in the case of multiple subscripts, hyphens may be necessary to avoid misunderstanding.

Examples: I_{B2} = continuous (d.c.) current flowing into the second base terminal

V_{B2-E} = continuous (d.c.) voltage between the terminals of second base and emitter

Subscripts for multiple devices

For multiple unit devices, the subscripts are modified by a number preceding the letter subscript; in the case of multiple subscripts, hyphens may be necessary to avoid misunderstanding.

Examples: I_{2C} = continuous (d.c.) current flowing into the collector terminal of the second unit

V_{1C-2C} = continuous (d.c.) voltage between the collector terminals of the first and the second unit.

Application of the rules

The figure below represents a transistor collector current as a function of time. It consists of a continuous (d. c.) current and a varying component.

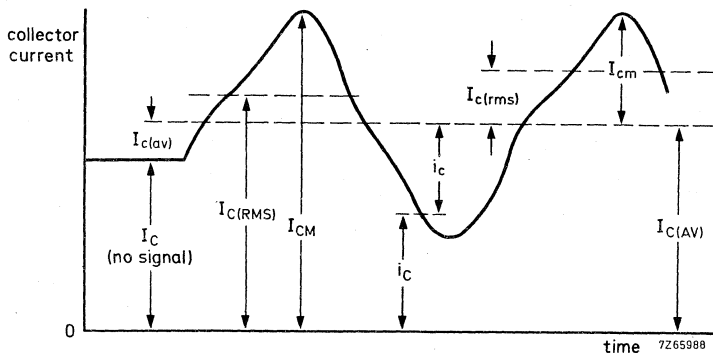

LETTER SYMBOLS FOR ELECTRICAL PARAMETERS

Definition

For the purpose of this Publication, the term "electrical parameter" applies to four-pole matrix parameters, elements of electrical equivalent circuits, electrical impedances and admittances, inductances and capacitances.

Basic letters

The following is a list of the most important basic letters used for electrical parameters of semiconductor devices.

- B, b = susceptance; imaginary part of an admittance
- C = capacitance
- G, g = conductance; real part of an admittance
- H, h = hybrid parameter
- L = inductance
- R, r = resistance; real part of an impedance
- X, x = reactance; imaginary part of an impedance
- Y, y = admittance;
- Z, z = impedance;

Upper-case letters shall be used for the representation of:

- a) electrical parameters of external circuits and of circuits in which the device forms only a part;
- b) all inductances and capacitances.

Lower-case letters shall be used for the representation of electrical parameters inherent in the device (with the exception of inductances and capacitances).

Subscripts

General subscripts

The following is a list of the most important general subscripts used for electrical parameters of semiconductor devices:

F, f	= forward; forward transfer
I, i (or 1)	= input
L, l	= load
O, o (or 2)	= output
R, r	= reverse; reverse transfer
S, s	= source

Examples: Z_S , h_f , h_F

The upper-case variant of a subscript shall be used for the designation of static (d.c.) values.

Examples : h_{FE} = static value of forward current transfer ratio in common-emitter configuration (d.c. current gain)

R_E = d.c. value of the external emitter resistance.

Note: The static value is the slope of the line from the origin to the operating point on the appropriate characteristic curve, i.e. the quotient of the appropriate electrical quantities at the operating point.

The lower-case variant of a subscript shall be used for the designation of small-signal values.

Examples: h_{fe} = small-signal value of the short-circuit forward current transfer ratio in common-emitter configuration

$Z_e = R_e + jX_e$ = small-signal value of the external impedance

Note: If more than one subscript is used, subscripts for which both styles exist shall either be all upper-case or all lower-case

Examples: h_{FE} , y_{RE} , h_{fe}

Subscripts for four-pole matrix parameters

The first letter subscript (or double numeric subscript) indicates input, output, forward transfer or reverse transfer

Examples: h_i (or h_{11})
 h_o (or h_{22})
 h_f (or h_{21})
 h_r (or h_{12})

A further subscript is used for the identification of the circuit configuration. When no confusion is possible, this further subscript may be omitted.

Examples: h_{fe} (or h_{21e}), h_{FE} (or h_{21E})

Distinction between real and imaginary parts

If it is necessary to distinguish between real and imaginary parts of electrical parameters, no additional subscripts should be used. If basic symbols for the real and imaginary parts exist, these may be used.

Examples: $Z_i = R_i + jX_i$
 $y_{fe} = g_{fe} + jb_{fe}$

If such symbols do not exist or if they are not suitable, the following notation shall be used:

Examples: $\text{Re}(h_{ib})$ etc. for the real part of h_{ib}
 $\text{Im}(h_{ib})$ etc. for the imaginary part of h_{ib}

PRO-ELECTRON COLOUR CODING SYSTEM FOR PROFESSIONAL SMALL SIGNAL DIODES

Letter combination-background colour

BAV - green
BAW - blue
BAX - black

Figure combination-colour bands

0 - black
1 - brown
2 - red
3 - orange
4 - yellow
5 - green
6 - blue
7 - violet
8 - grey
9 - white

The cathode side is indicated by a broad band which is at the same time the first digit of the figure combination.

Note: For BA types see individual type publications.

JEDEC assigned type numbers

(EIA-standard RS-236-B; June, 1963)

1. Prefix identification

The prefix identification consisting of a first number symbol and the letter "N" shall not be indicated in the coding.

2. Banding systems

The sequence number consisting of a two, three, or four digit number after the letter "N" may be coded as follows:

- 2.1 Two-digit sequence numbers shall consist of a first black band and the sequence number in second and third bands of the colours indicated in Table 1. If a suffix letter is required, it shall be indicated with a fourth band as indicated in Table 1.
- 2.2 Three-digit sequence numbers shall consist of the sequence number in first, second, and third bands of the colours indicated in Table 1. If a suffix letter is required, it shall be indicated with a fourth band as indicated in Table 1.
- 2.3 Four-digit sequence numbers shall consist of the sequence number in four bands of the colours indicated in Table 1.
If a suffix letter is required it shall be indicated as the fifth band.

3. Cathode identification and reading sequence

- 3.1 A double-width band shall be used as the first band reading from cathode to anode ends.
- 3.2 An alternative method is provided where equal width bands may be used. The bands shall be clearly grouped toward the cathode end, and shall be read from cathode to anode ends.
- 3.3 Either of the above colour banding methods may be used in stead of the cathode designating symbol or other marking.

4. Colour bands

The sequence numbers of the type numbers and suffix letters shall be indicated by the colours in Table 1.

TABLE 1

NUMBER	COLOUR	SUFFIX LETTER
0	black	not applicable
1	brown	A
2	red	B
3	orange	C
4	yellow	D
5	green	E
6	blue	F
7	violet	G
8	grey	H
9	white	J

BANDOLIER AND REEL SPECIFICATION
for DO-7; DO-35 and SOD-17 envelopes

Configuration of bandolier

Dimensions in mm

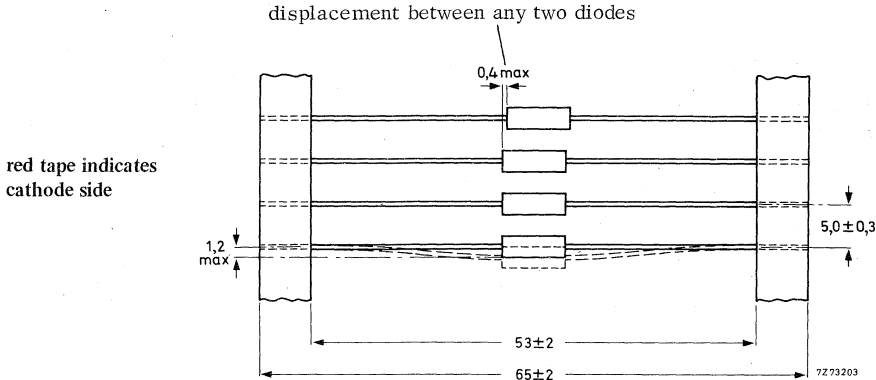

Reel dimensions

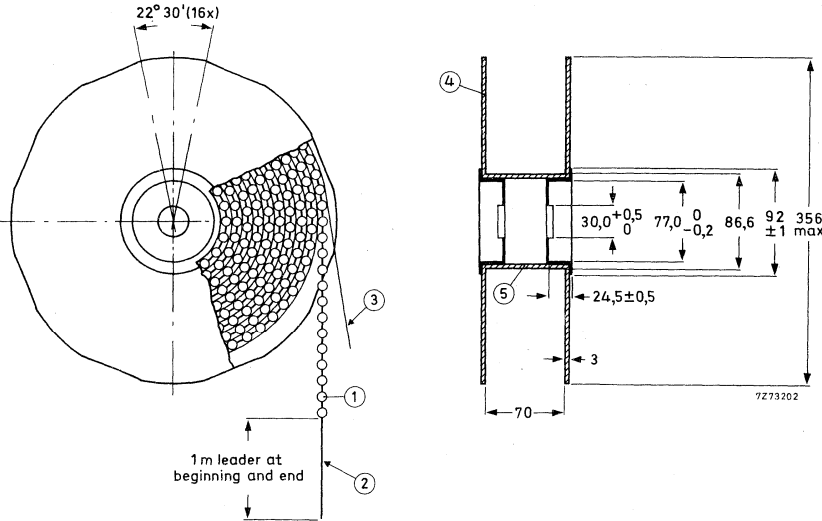

- (1) Diode
- (2) Bandolier
- (3) Paper
- (4) Flange
- (5) Cylinder

RULES FOR MOUNTING AND SOLDERING

Introduction

Excessive forces or temperatures applied to a diode may cause serious damage to the diode. To avoid damage when soldering and mounting the following rules should be followed.

General

Perpendicular forces on the body of the diode must be avoided.

Avoid sudden forces on the leads or body. These forces often are much higher than allowed.

High acceleration forces as a result of any shock (dropping on a hard surface for instance) must be prevented.

Bending

During bending the leads must be supported between body or stud (SOD-17) and bending point.

Axial forces on the body during the bending process must not exceed 20 N.

Bending the leads through 90° is allowed at any distance from the body when it is possible to support the leads during bending without contacting the envelope or weldings.

Bending close to the body or stud without supporting the leads only is allowed if the bend radius is greater than 0,5 mm; in practice this limit will be met by hand bending without applying high pulling or pressing forces.

Twisting

Twisting the leads is allowed at any distance from the body or stud if the lead is properly clamped between body or stud and twisting point.

Without clamping, twisting the leads is only allowed at a distance of greater than 3 mm from the body; the torque angle must not exceed 30°, the applied force not higher than 15 mNm.

Straightening

Straightening the leads is allowed if the applied pulling force in the axial direction does not exceed 20 N and the total duration is not longer than 5 seconds.

Soldering

Avoid any force on the body or leads during or just after soldering.

Do not correct the position of an already soldered device by pushing, pulling or twisting the body.

MOUNTING AND SOLDERING

Do not solder a diode upright with one end of the body directly on the surface of the printed-circuit board, there should be at least 0,5 mm between body end and print surface.

When the device is to be mounted with straight or short-cropped leads, solder the leads individually.

Bent leads may be soldered simultaneously.

The diode can be mounted flat on the printed-circuit board when the body temperature of the diode will not exceed:

- the maximum allowed junction temperature, where this is higher than 175 °C;
- 115 °C for more than 2 minutes (with an absolute peak temperature for the junction of 160 °C), where the maximum junction temperature is less than 175 °C.

Any contact between diode body and hot spots on the printed-circuit board (such as copper layers) must be avoided.

Prevent fast cooling after soldering.

Minimum distance soldering point to seal and maximum allowable soldering time for several envelopes.

DO-7, germanium
(glass)

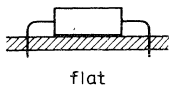

Hand soldering iron

(Max. solder temp. : 300 °C)

time : 3 s
distance: 5 mm

Dip or wave soldering

(Max. solder temp. : 260 °C)

time : 5 s
distance: 5 mm

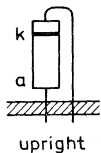

time : 4 s
distance
anode: 2 mm
cathode: 13 mm

time : 5 s
distance
anode: 2 mm
cathode: 13 mm

DO-7, silicon
(glass)

Flat and upright
mounting

time : 5 s
distance: 4 mm
(anode: 2 mm)

time : 5 s
distance: 4 mm
(anode: 2 mm)

DO-35, SOD-17, SOD-51
(glass)

Flat and upright
mounting

time : 5 s
distance: 1,5 mm

time : 5 s
distance: 1,5 mm

SOD-23, SOT-33
(plastic)

time : 3 s
distance: 0,5 mm

time : 5 s
distance: 0,5 mm



Germanium small signal diodes

Point contact

POINT CONTACT DIODES

Germanium diodes in DO-7 envelope

Quoted values are max.

	type	V_R (V)	I_F (mA)	I_{FRM} (mA)	t_{rr} (ns)	C_d (pF)	V_F at I_F (V)	I_F (mA)
general purpose	OA90	20	8	45	—	—	1,5	10
	OA91	90	50	150	—	—	1,9	10
	OA95	90	50	150	—	—	1,5	10
switching	AAY21	15	20	50 *)	12	1,2	0,8	10
a. m. and f. m. detection	AA119 ; 2-AA119	30	35	100	—	—	2,2	10

*) I_{FM}

MECHANICAL DATA

Dimensions in mm

DO-7

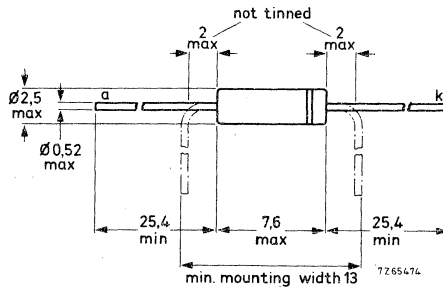

Cathode indicated by coloured band

POINT CONTACT DIODE

Germanium diode in all-glass DO-7 envelope primarily intended for use in a.m. detector and ratio detector circuits.

QUICK REFERENCE DATA			
Continuous reverse voltage	V_R	max.	30 V
Repetitive peak reverse voltage	V_{RRM}	max.	45 V
Forward current (d.c.)	I_F	max.	35 mA
Repetitive peak forward current	I_{FRM}	max.	100 mA
Operating ambient temperature	T_{amb}	max.	60 °C
Forward voltage at $I_F = 10$ mA	V_F	<	2.2 V

MECHANICAL DATA

Dimensions in mm

DO-7

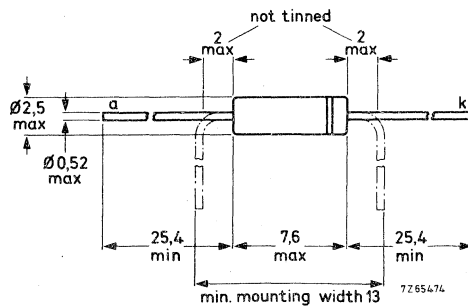

The coloured band indicates the cathode

RATINGS Limiting values in accordance with the Absolute Maximum System (IEC134)

Voltages

Continuous reverse voltage	V_R	max.	30	V
Repetitive peak reverse voltage	V_{RRM}	max.	45	V

Currents

Forward current (d. c.)	I_F	max.	35	mA
Average rectified forward current (averaged over any 20 ms period)	$I_{F(AV)}$	max.	35	mA
Repetitive peak forward current	I_{FRM}	max.	100	mA
Non-repetitive peak forward current ($t < 1$ s)	I_{FSM}	max.	200	mA

Temperatures

Storage temperature	T_{stg}	-55 to +75	°C
Operating ambient temperature	T_{amb}	max. 60	°C

THERMAL RESISTANCE

From junction to ambient in free air	$R_{th\ j-a}$	=	0,65	°C/mW
--------------------------------------	---------------	---	------	-------



CHARACTERISTICS

Forward voltage at $T_{amb} = 25\text{ }^{\circ}\text{C}$

$I_F = 0.1\text{ mA}$	V_F	typ. 0.23 V
		< 0.30 V
$I_F = 1\text{ mA}$	V_F	typ. 0.56 V
		< 0.88 V
$I_F = 10\text{ mA}$	V_F	typ. 1.5 V
		< 2.2 V
$I_F = 30\text{ mA}^1)$	V_F	typ. 2.8 V
		< 4.0 V

Forward voltage at $T_{amb} = 60\text{ }^{\circ}\text{C}$

$I_F = 0.1\text{ mA}$	V_F	typ. 0.16 V
		< 0.25 V
$I_F = 1\text{ mA}$	V_F	typ. 0.50 V
		< 0.80 V
$I_F = 10\text{ mA}$	V_F	typ. 1.4 V
		< 2.1 V
$I_F = 30\text{ mA}^1)$	V_F	typ. 2.6 V
		< 3.8 V

Reverse current at $T_{amb} = 25\text{ }^{\circ}\text{C}$

$V_R = 0.1\text{ V}$	I_R	typ. 0.35 μA
		< 1.0 μA
$V_R = 1.5\text{ V}$	I_R	typ. 0.8 μA
		< 2.8 μA
$V_R = 10\text{ V}$	I_R	typ. 4.5 μA
		< 18 μA
$V_R = 30\text{ V}$	I_R	typ. 35 μA
		< 150 μA
$V_R = 45\text{ V}$	I_R	typ. 90 μA
		< 350 μA

Reverse current at $T_{amb} = 60\text{ }^{\circ}\text{C}$

$V_R = 0.1\text{ V}$	I_R	typ. 4.5 μA
		< 12 μA
$V_R = 1.5\text{ V}$	I_R	typ. 6 μA
		< 25 μA
$V_R = 10\text{ V}$	I_R	typ. 16 μA
		< 60 μA
$V_R = 30\text{ V}$	I_R	typ. 60 μA
		< 300 μA
$V_R = 45\text{ V}$	I_R	typ. 170 μA
		< 500 μA

¹⁾ Measured under pulsed conditions to prevent excessive dissipation.

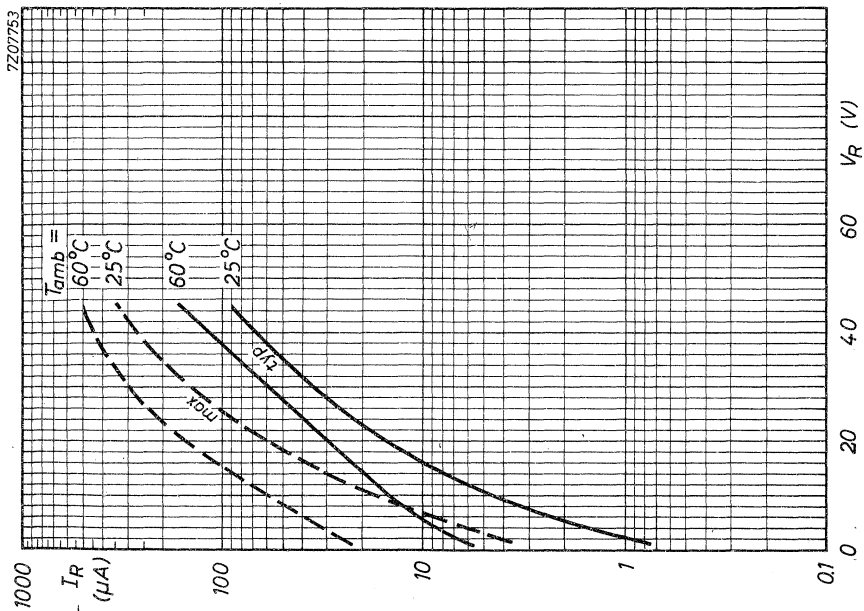
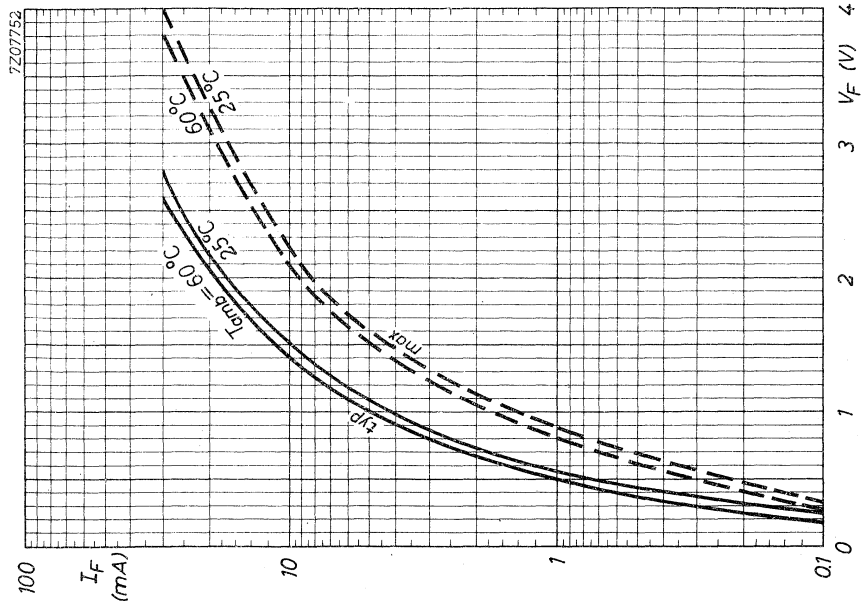

POINT CONTACT DIODE

Germanium diode in all-glass DO-7 envelope primarily intended for computer applications.

MECHANICAL DATA

Dimensions in mm

DO-7

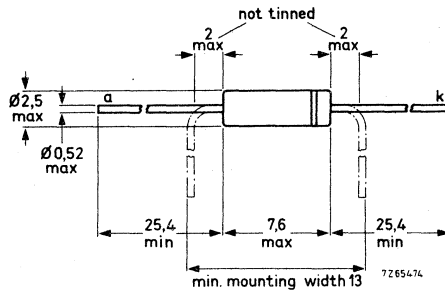

The coloured band indicates the cathode

RATINGS Limiting values in accordance with the Absolute Maximum System (IEC134)

Voltage

Continucus reverse voltage V_R max. 15 V

Currents

Forward current (d. c.) I_F max. 20 mA

Peak forward current I_{FM} max. 50 mA

Temperatures

Storage temperature T_{stg} -65 to +75 °C

Junction temperature T_j max. 75 °C

Operating ambient temperature T_{amb} max. 60 °C

THERMAL RESISTANCE

From junction to ambient in free air $R_{th j-a}$ = 0,75 °C/mW

CHARACTERISTICS

$T_j = 25\text{ }^\circ\text{C}$ unless otherwise specified

Forward voltage

$I_F = 2\text{ mA}$	V_F	0,25 to 0,45	V
$I_F = 2\text{ mA}; T_j = 60\text{ }^\circ\text{C}$	V_F	0,19 to 0,39	V
$I_F = 10\text{ mA}$	V_F	0,40 to 0,80	V
$I_F = 10\text{ mA}; T_j = 60\text{ }^\circ\text{C}$	V_F	0,34 to 0,74	V
$I_F = 50\text{ mA}$	V_F	0,60 to 1,50	V
$I_F = 50\text{ mA}; T_j = 60\text{ }^\circ\text{C}$	V_F	0,54 to 1,44	V

Reverse current

$V_R = 5\text{ V}; T_{amb} = 60\text{ }^\circ\text{C}$	I_R	< 30	μA
$V_R = 5\text{ V}; T_{amb} = 25\text{ }^\circ\text{C}$	I_R	< 10	μA
$V_R = 15\text{ V}; T_{amb} = 60\text{ }^\circ\text{C}$	I_R	< 100	μA
$V_R = 15\text{ V}; T_{amb} = 25\text{ }^\circ\text{C}$	I_R	< 60	μA

Diode capacitance

$V_R = 1\text{ V}; f = 0,5\text{ MHz}$	C_d	< 1,2	pF
--	-------	-------	----

Reverse recovery current when switched from

$I_F = 3\text{ mA}$ to $V_R = 5\text{ V}; R_L = 0,5\text{ k}\Omega$; measured at $t_{rr} = 50\text{ ns}$	I_R	< 0,5	mA
--	-------	-------	----

Reverse recovery time when switched from

$I_F = 3\text{ mA}$ to $V_R = 1\text{ V}; R_L = 100\text{ }\Omega$; measured at $I_R = 1\text{ mA}$	t_{rr}	typ. < 5	ns
		< 12	ns

POINT CONTACT DIODE

Germanium diode in all-glass DO-7 envelope for use as video detector and for general purposes.

MECHANICAL DATA

Dimensions in mm

DO-7

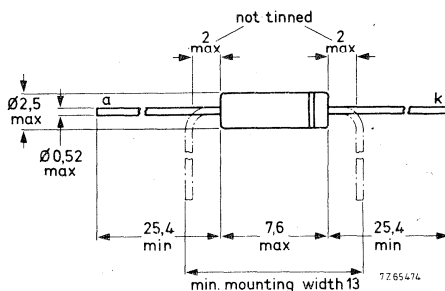

The coloured band indicates the cathode

RATINGS Limiting values in accordance with the Absolute Maximum System (IEC 134)

Average reverse voltage (averaged over any 20 ms period)	V_R	max.	20 V	←
Repetitive peak reverse voltage	V_{RRM}	max.	30 V	
Non-repetitive peak reverse voltage	V_{RSM}	max.	40 V	
Average forward current (averaged over any 20 ms period)	$I_F(AV)$	max.	8 mA	←
Repetitive peak forward current	I_{FRM}	max.	45 mA	
Non-repetitive peak forward current ($t < 1$ s)	I_{FSM}	max.	200 mA	
Storage temperature	T_{stg}		-55 to +90 °C	
Operating ambient temperature	T_{amb}		-55 to +75 °C	

CHARACTERISTICS

		$T_{amb} = 25$ °C		60 °C	
<u>Forward voltage</u>					
$I_F = 0.1$ mA	V_F	typ.	0.18	typ.	0.12 V
			0.1 to 0.25	<	0.20 V
$I_F = 10$ mA	V_F	typ.	1.0	typ.	0.95 V
			0.5 to 1.5		0.4 to 1.4 V
$I_F = 30$ mA	V_F	typ.	2.0	typ.	1.95 V
			1.1 to 3.2		1.0 to 3.1 V
<u>Reverse current</u>					
$V_R = 1.5$ V	I_R	typ.	2.4	typ.	11 μA
			< 10	<	40 μA
$V_R = 10$ V	I_R	typ.	20	typ.	45 μA
			< 135	<	270 μA
$V_R = 20$ V	I_R	typ.	90	typ.	140 μA
			< 450	<	650 μA
$V_R = 30$ V	I_R	typ.	300	typ.	400 μA
			< 1100	<	1500 μA

APPLICATION INFORMATION

Measuring circuit

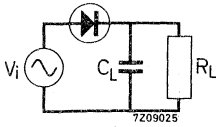

V_{im}	=	5	1.4	0.5	5	V
f	=	40	40	40	30	MHz
C_L	=	10	10	10	10	pF
R_L	=	3	3	3	3.9	k Ω
η	typ.	63	54	34	>60	%
R_d	typ.	2.4	2.8	3.7	>2.9	k Ω

Video detector circuit

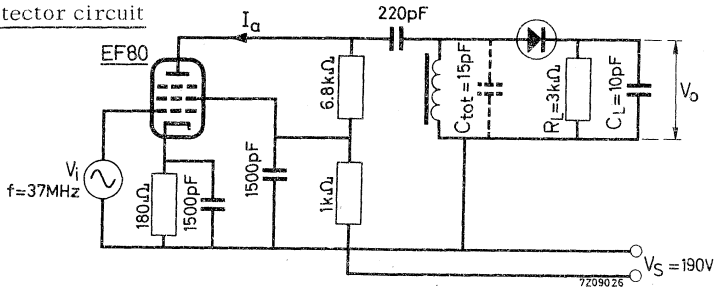

Q of the tuned circuit with removed diode: $Q = 19$

$I_{am} = 2.5 \quad 0.25 \quad \text{mA}$

$B = 4.7 \quad 4.1 \quad \text{MHz}$

$V_o \text{ typ. } 2.7 \quad 0.20 \quad \text{V}$

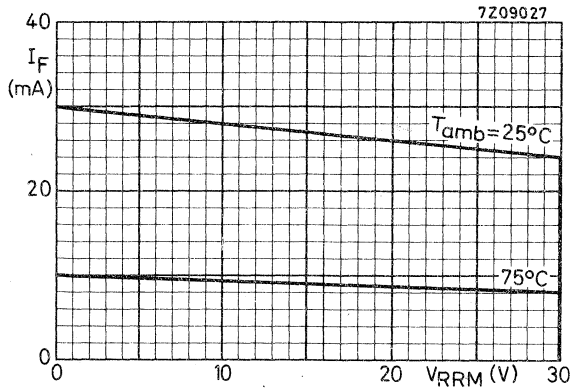

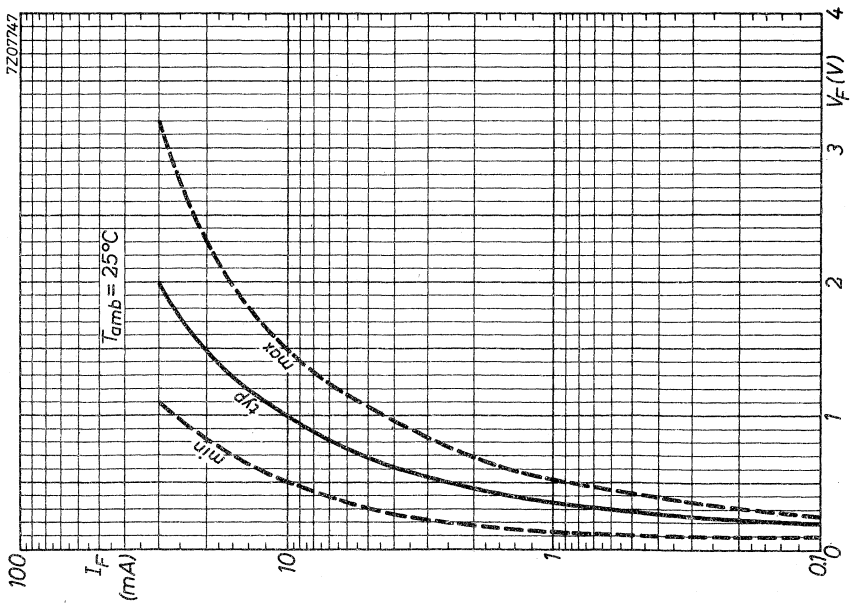
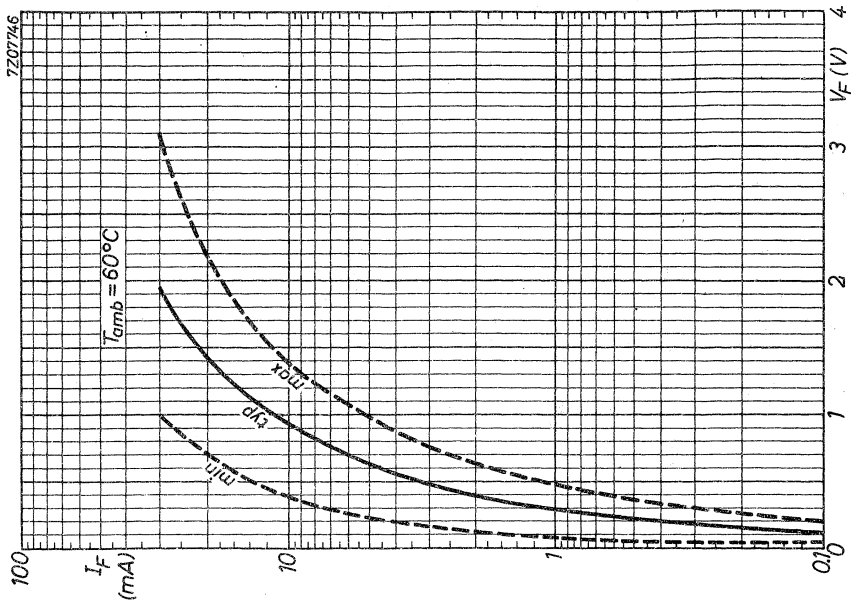

7207746
7207747
7207748
7207749
7207750
7207751

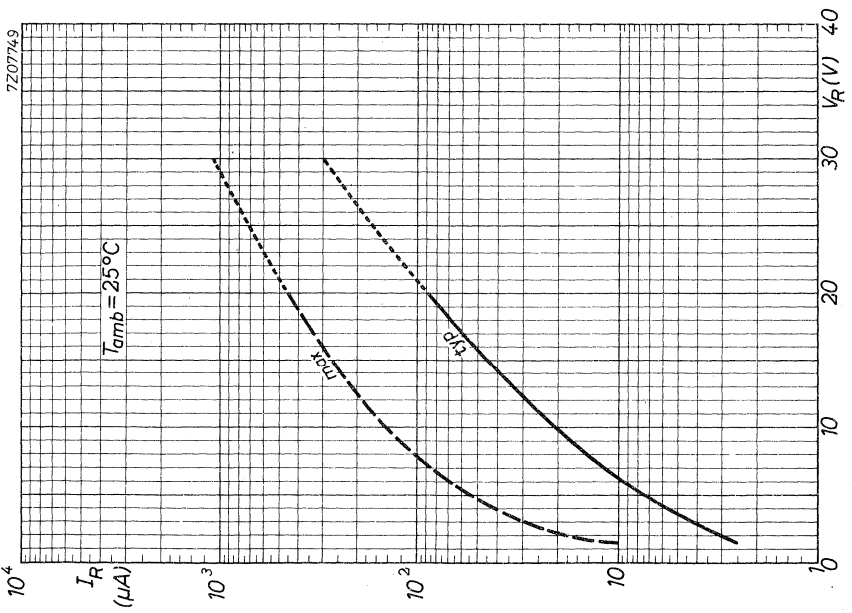
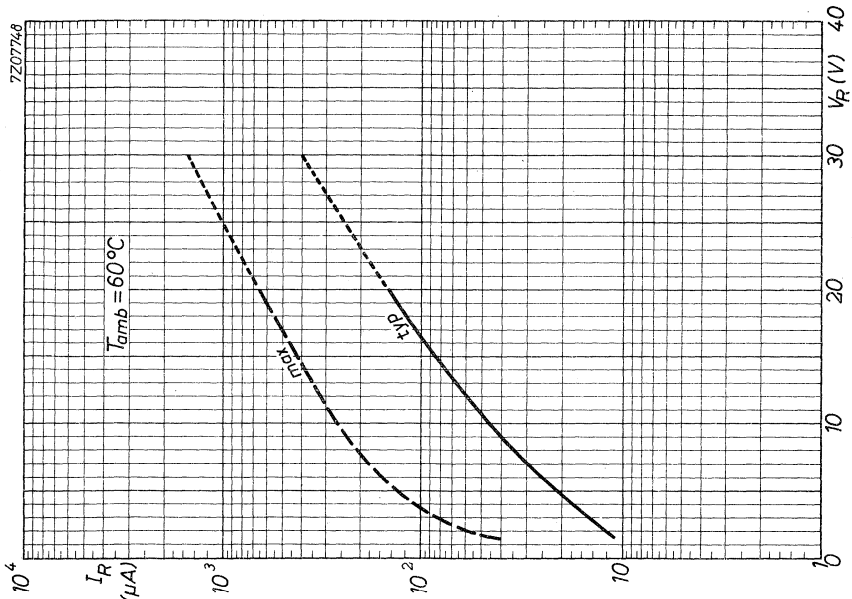

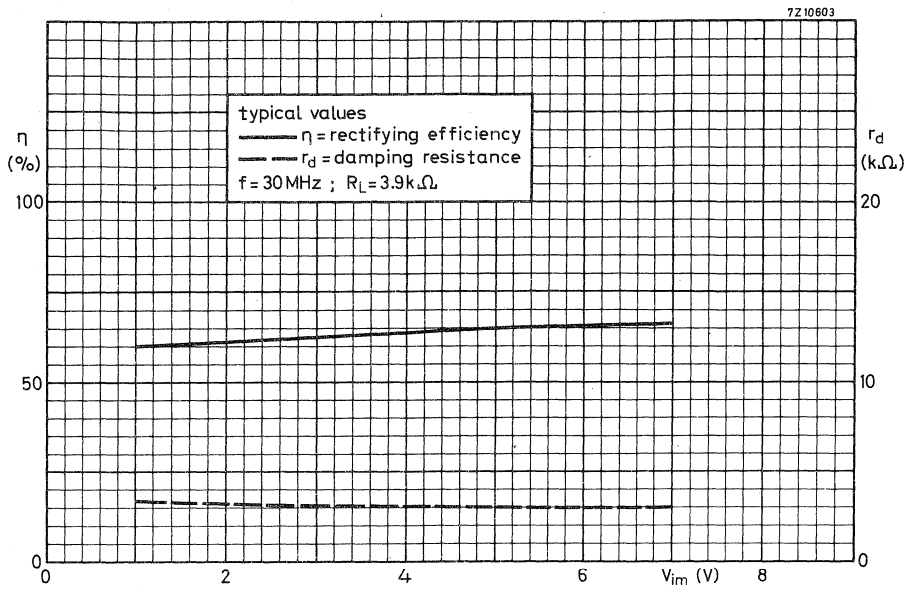

POINT CONTACT DIODE

Germanium diode in all-glass DO-7 envelope intended for general purposes.

MECHANICAL DATA

Dimensions in mm

DO-7

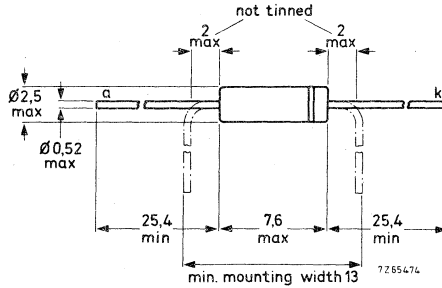

The coloured band indicates the cathode

RATINGS Limiting values in accordance with the Absolute Maximum System (IEC 134)

Average reverse voltage (averaged over any 20 ms period)	V_R	max.	90 V	←
Repetitive peak reverse voltage	V_{RRM}	max.	115 V	
Average forward current (averaged over any 20 ms period)	$I_F(AV)$	max.	50 mA	←
Repetitive peak forward current	I_{FRM}	max.	150 mA	
Non-repetitive peak forward current ($t < 1$ s)	I_{FSM}	max.	500 mA	
Storage temperature	T_{stg}		-55 to +75 °C	
Ambient temperature	T_{amb}		-55 to +75 °C	

THERMAL RESISTANCE

From junction to ambient in free air $R_{th\ j-a} = 0.55$ °C/mW

CHARACTERISTICS

Forward voltage

$I_F = 0.1$ mA

	$T_{amb} = 25$ °C	$T_{amb} = 60$ °C
V_F	typ. 0.18 0.1 to 0.25	typ. 0.1 V 0.05 to 0.2 V

$I_F = 10$ mA

V_F	typ. 1.2 0.65 to 1.9	typ. 1.05 V 0.55 to 1.8 V
-------	-------------------------	------------------------------

$I_F = 30$ mA

V_F	typ. 2.1 1.0 to 3.3	typ. 1.9 V 0.9 to 3.15 V
-------	------------------------	-----------------------------

Reverse current

$V_R = 1.5$ V

I_R	typ. 1.5 0.3 to 7	typ. 15 μ A 6 to 45 μ A
-------	----------------------	------------------------------------

$V_R = 10$ V

I_R	typ. 4 0.5 to 11	typ. 20 μ A 9 to 60 μ A
-------	---------------------	------------------------------------

$V_R = 75$ V

I_R	typ. 40 5.5 to 180	typ. 115 μ A 35 to 260 μ A
-------	-----------------------	---------------------------------------

$V_R = 100$ V

I_R	typ. 75 10 to 275	typ. 190 μ A 60 to 450 μ A
-------	----------------------	---------------------------------------

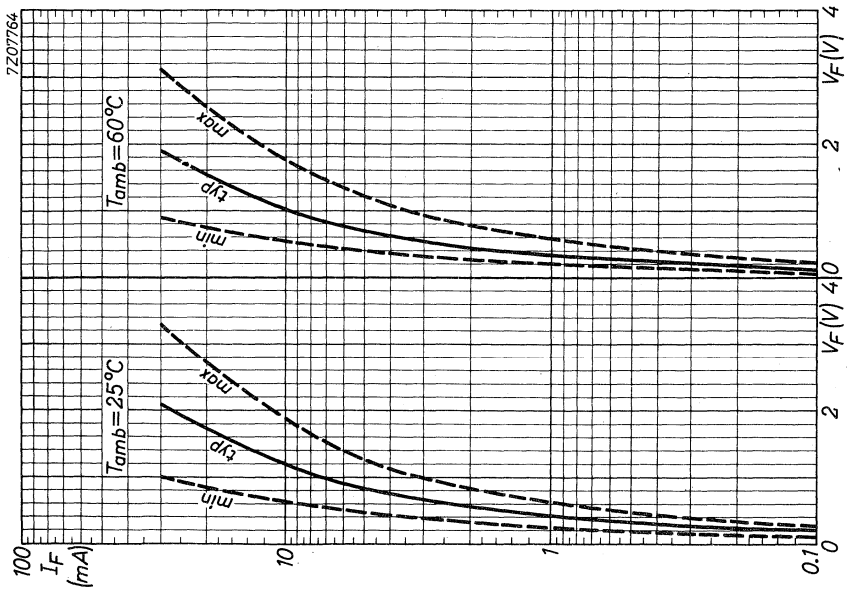
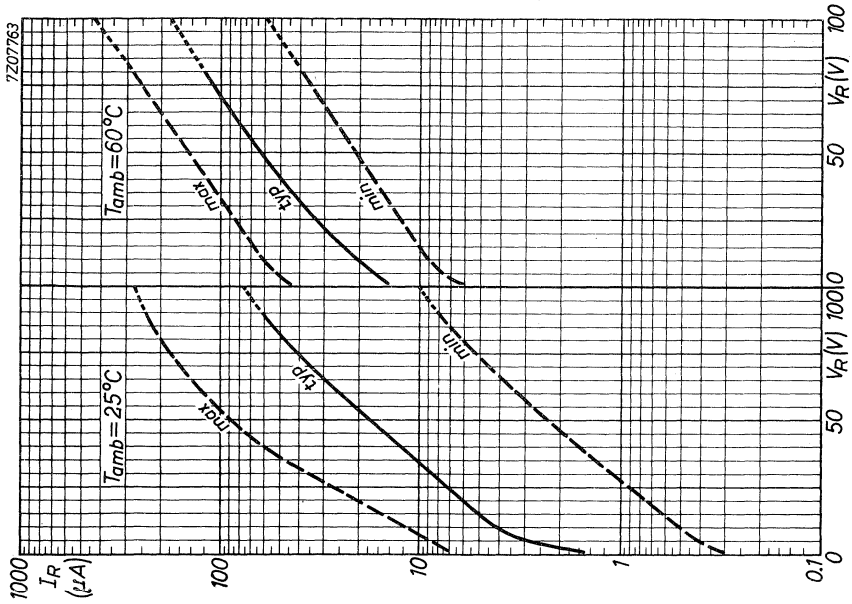

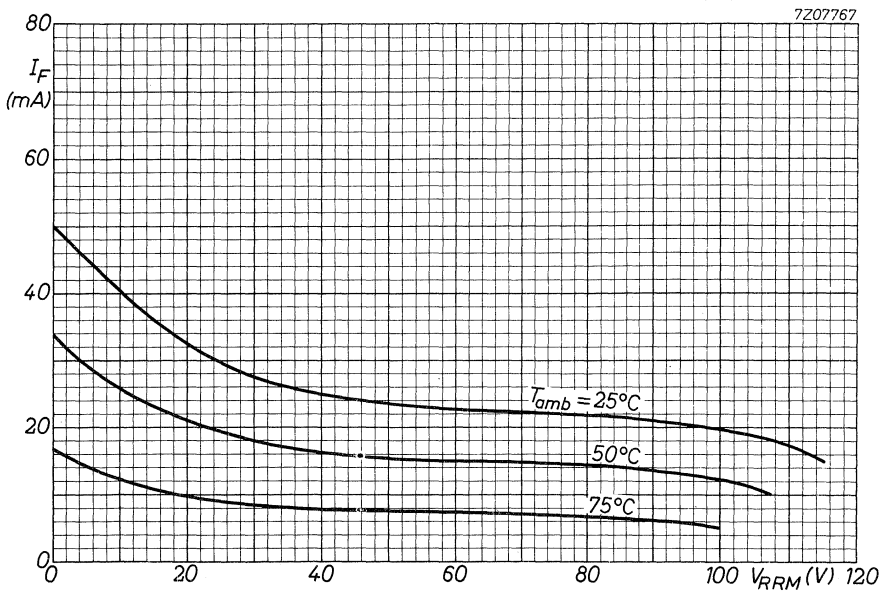
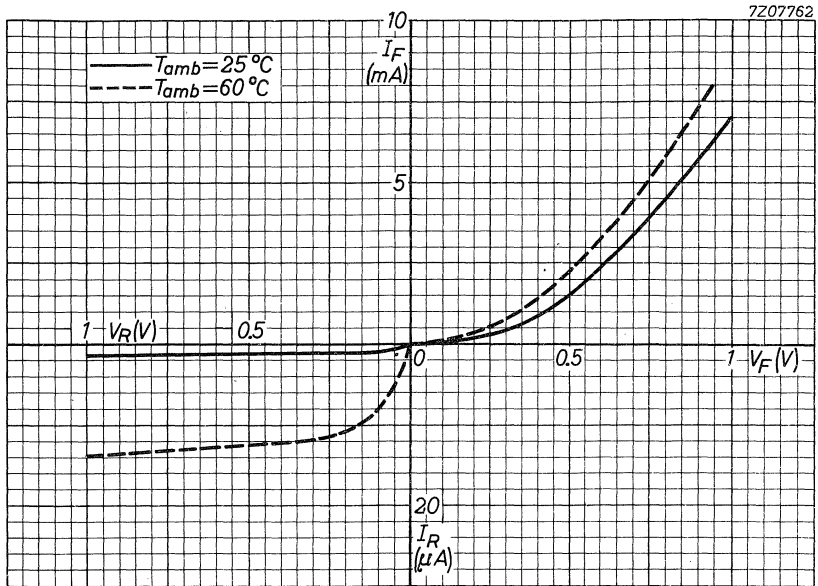

POINT CONTACT DIODE

Germanium diode in all-glass DO-7 envelope intended for general purposes.

MECHANICAL DATA

Dimensions in mm

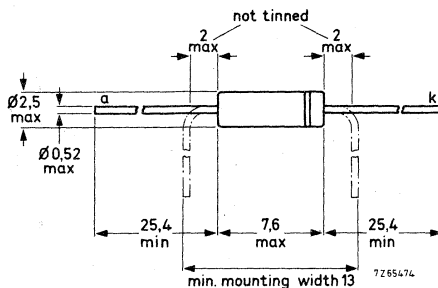

The coloured band indicates the cathode

RATINGS Limiting values in accordance with the Absolute Maximum System (IEC134)

Average reverse voltage (averaged over any 20 ms period)

V_R max. 90 V ←

Repetitive peak reverse voltage

V_{RRM} max. 115 V

Average forward current (averaged over any 20 ms period)

$I_F(AV)$ max. 50 mA ←

Repetitive peak forward current

I_{FRM} max. 150 mA

Non-repetitive peak forward current ($t < 1$ s)

I_{FSM} max. 500 mA

Storage temperature

T_{stg} -55 to +75 °C

Ambient temperature

T_{amb} -55 to +75 °C

THERMAL RESISTANCE

From junction to ambient in free air

$R_{th j-a}$ = 0.55 °C/mW

CHARACTERISTICS

Forward voltage

$I_F = 0.1$ mA

	$T_{amb} = 25$ °C	$T_{amb} = 60$ °C
V_F	typ. 0.18	typ. 0.1 V
	0.1 to 0.25	0.05 to 0.2 V
V_F	typ. 1.05	typ. 0.95 V
	0.65 to 1.5	0.55 to 1.4 V
V_F	typ. 1.85	typ. 1.75 V
	1.0 to 2.6	0.9 to 2.5 V
I_R	typ. 1.2	typ. 12 μ A
	0.4 to 4.5	5.5 to 26 μ A
I_R	typ. 2.5	typ. 17 μ A
	0.8 to 7	8 to 40 μ A
I_R	typ. 35	typ. 100 μ A
	5.7 to 110	20 to 250 μ A
I_R	typ. 80	typ. 200 μ A
	10 to 250	30 to 430 μ A

Reverse current

$V_R = 1.5$ V

$V_R = 10$ V

$V_R = 75$ V

$V_R = 100$ V

7Z07771

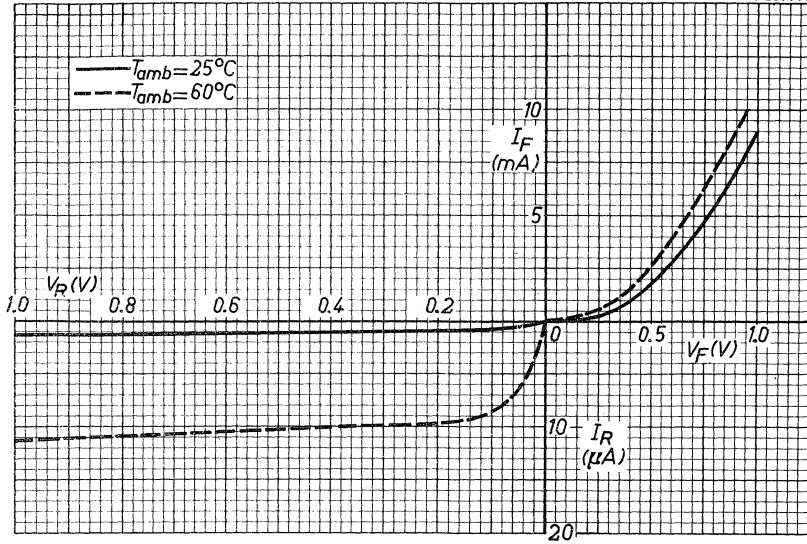

7Z07767

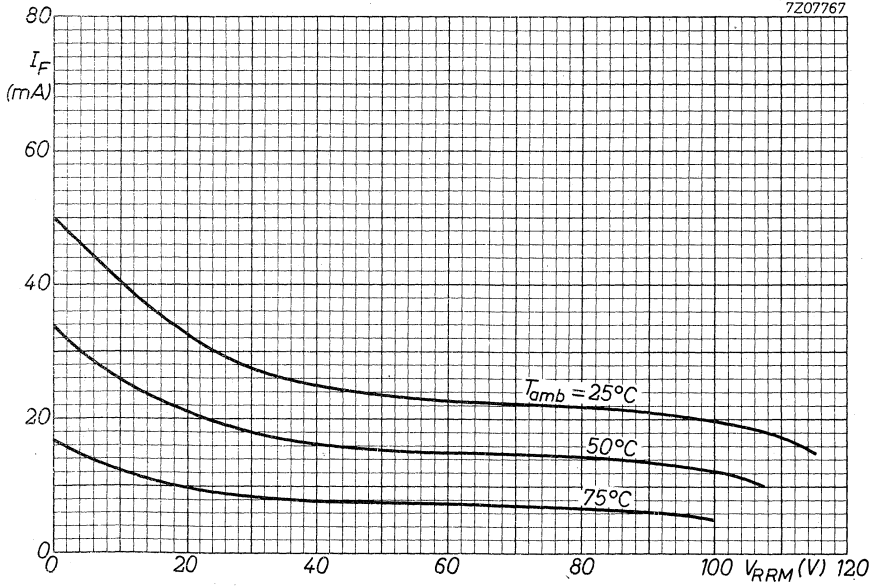

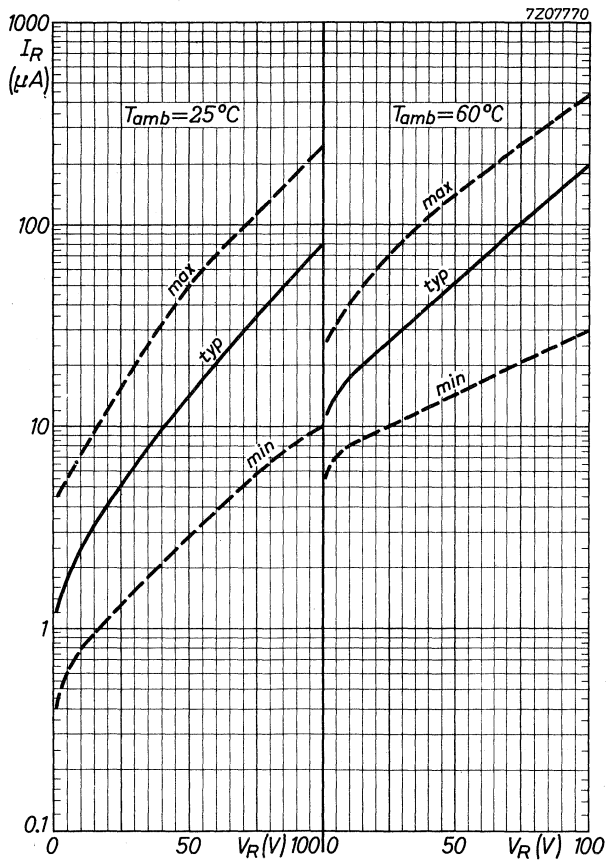

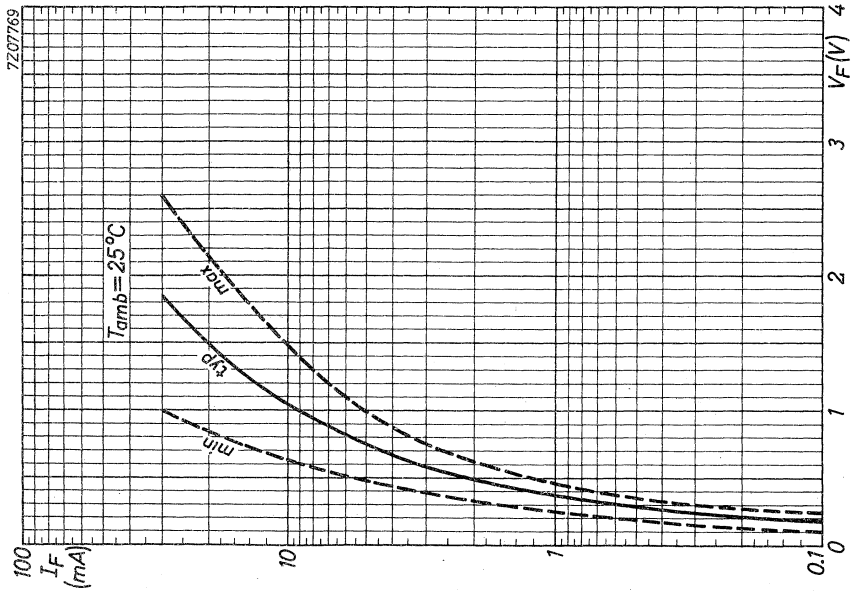
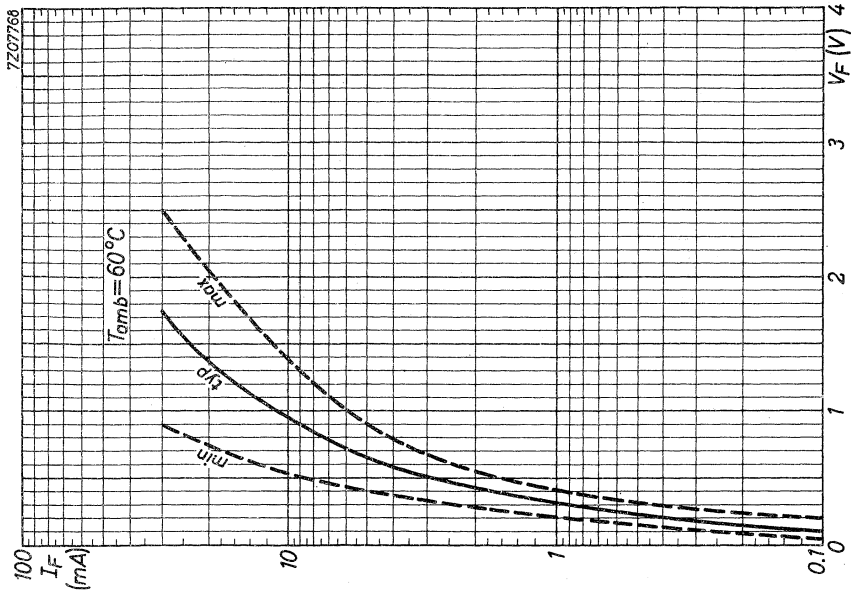

Germanium small signal diodes
Gold bonded



GOLD BONDED DIODES

Germanium diodes in DO-7 envelope

Quoted values are max.

	type	V_R (V)	I_F (mA)	I_{FRM} (mA)	t_{rr} (ns)	C_d (pF)	V_F at I_F (V)	I_F (mA)
general purpose	AAZ15	75	140	250	—	2	1,1	250
	AAZ17	50	140	250	—	2	1,1	250
general purpose and switching	AAZ30	30	110	400	150	2,0	1,0	150
	AAZ32	30	110	150	50	1,5	1,0	150
	AAZ13	8	30	100	—	2,0	1,0	30
	AAZ18	20	130	300	70	2,5	1,0	300
	OA47	25	110	150	70	3,5	1,1	150

MECHANICAL DATA

Dimensions in mm

DO-7

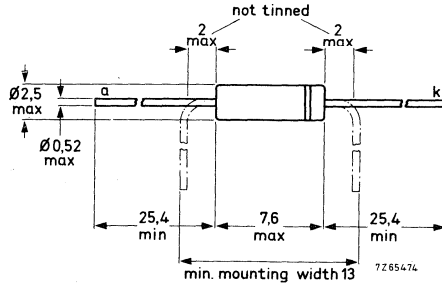

Cathode indicated by coloured band

GOLD BONDED DIODES

Germanium diodes in all-glass DO-7 envelope, intended for switching applications and general purposes.

QUICK REFERENCE DATA			AA Y30	AA Y32
Continuous reverse voltage	V_R	max.	30	30 V
Repetitive peak reverse voltage	V_{RRM}	max.	50	30 V
Forward current (d. c.)	I_F	max.	110	110 mA
Repetitive peak forward current	I_{FRM}	max.	400	150 mA
Junction temperature	T_j	max.	75	85 °C
Forward voltage at $I_F = 150$ mA	V_F	<	1,0	1,0 V
Recovery charge when switched from $I_F = 10$ mA to $V_R = 10$ V	Q_S	<	500	150 pC

MECHANICAL DATA

Dimensions in mm

DO-7

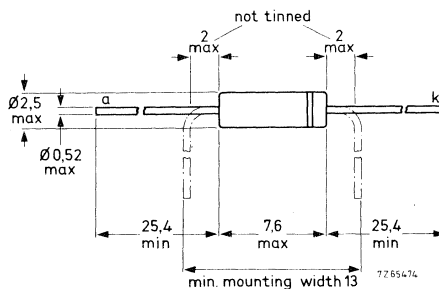

The coloured band indicates the cathode

AA Y30
AA Y32

RATINGS Limiting values in accordance with the Absolute Maximum System (IEC134)

<u>Voltages</u>		AA Y30	AA Y32
Continuous reverse voltage	V_R max.	30	30 V
Repetitive peak reverse voltage	V_{RRM} max.	50	30 V
Non-repetitive peak reverse voltage	V_{RSM} max.	50	30 V
<u>Currents</u>			
Forward current (d. c.)	I_F max.	110	110 mA
Average rectified forward current (averaged over any 20 ms period)	$I_{F(AV)}$ max.	110	110 mA
Repetitive peak forward current	I_{FRM} max.	400	150 mA
Non-repetitive peak forward current ($t < 1$ s)	I_{FSM} max.	500	200 mA

Temperatures

Storage temperature	AA Y30	T_{stg}	-65 to +75	°C
	AA Y32	T_{stg}	-65 to +85	°C
Junction temperature	AA Y30	T_j max.	75	°C
	AA Y32	T_j max.	85	°C

THERMAL RESISTANCE

From junction to ambient in free air	$R_{th j-a}$	=	0,55	°C/mW
--------------------------------------	--------------	---	------	-------

CHARACTERISTICS

Forward voltage at $T_j = 25\text{ }^\circ\text{C}$

$I_F = 0,1\text{ mA}$	$V_F <$	0,20	V
$I_F = 1,0\text{ mA}$	$V_F <$	0,31	V
$I_F = 10\text{ mA}$	$V_F <$	0,45	V
$I_F = 30\text{ mA}$	$V_F <$	0,60	V
$I_F = 150\text{ mA}$	$V_F <$	1,00	V

Forward voltage at $T_j = 60\text{ }^\circ\text{C}$

$I_F = 0,1\text{ mA}$	$V_F <$	0,14	V
$I_F = 1,0\text{ mA}$	$V_F <$	0,26	V
$I_F = 10\text{ mA}$	$V_F <$	0,41	V
$I_F = 30\text{ mA}$	$V_F <$	0,57	V
$I_F = 150\text{ mA}$	$V_F <$	0,99	V

Reverse current at $T_j = 25\text{ }^\circ\text{C}$

		AA Y30	AA Y32
$V_R = 1,5\text{ V}$	$I_R <$	9	2,5 μA
$V_R = 10\text{ V}$	$I_R <$	15	8 μA
$V_R = 20\text{ V}$	$I_R <$	25	25 μA
$V_R = 25\text{ V}$	$I_R <$	35	35 μA
$V_R = 30\text{ V}$	$I_R <$	50	70 μA
$V_R = 50\text{ V}$	$I_R <$	200	- μA

Reverse current at $T_j = 60\text{ }^\circ\text{C}$

$V_R = 1,5\text{ V}$	$I_R <$	40	15 μA
$V_R = 10\text{ V}$	$I_R <$	60	30 μA
$V_R = 20\text{ V}$	$I_R <$	120	60 μA
$V_R = 25\text{ V}$	$I_R <$	150	100 μA
$V_R = 30\text{ V}$	$I_R <$	200	200 μA
$V_R = 50\text{ V}$	$I_R <$	500	- μA

Diode capacitance at $T_j = 25\text{ }^\circ\text{C}$

$V_R = 1\text{ V}; f = 1\text{ MHz}$	$C_d <$	2,0	1,5 pF
--------------------------------------	---------	-----	--------

→ **CHARACTERISTICS** (continued)

$T_j = 25\text{ }^\circ\text{C}$

Reverse recovery time when switched from

$I_F = 10\text{ mA}$ to $I_R = 10\text{ mA}$; $R_L = 100\ \Omega$

measured at $I_R = 1\text{ mA}$

AA Y30	t_{rr}	<	150	ns
AA Y32	t_{rr}	<	50	ns

Test circuit and waveforms:

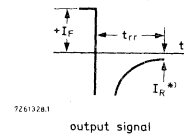
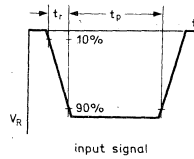
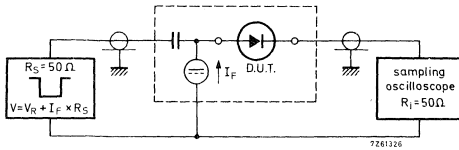

Input signal : Rise time of the reverse pulse

$t_r = 0,6\text{ ns}$

*) $I_R = 1\text{ mA}$

Reverse pulse duration

$t_p = 300\text{ ns}$

Duty factor

$\delta = 0,05$

Oscilloscope: Rise time

$t_r = 0,35\text{ ns}$

Circuit capacitance $C \leq 1\text{ pF}$ ($C =$ oscilloscope input capacitance + parasitic capacitance)

Recovery charge when switched from

$I_F = 10\text{ mA}$ to $V_R = 10\text{ V}$; $R_L = 1\text{ k}\Omega$

AA Y30	Q_S	<	500	pC
AA Y32	Q_S	<	150	pC

Test circuit and waveform:

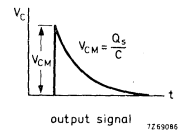
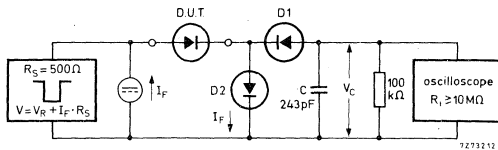

D1 = D2 = BAW62

Input signal: Rise time of the reverse pulse

$t_r = 2\text{ ns}$

Reverse pulse duration

$t_p = 400\text{ ns}$

Duty factor

$\delta = 0,02$

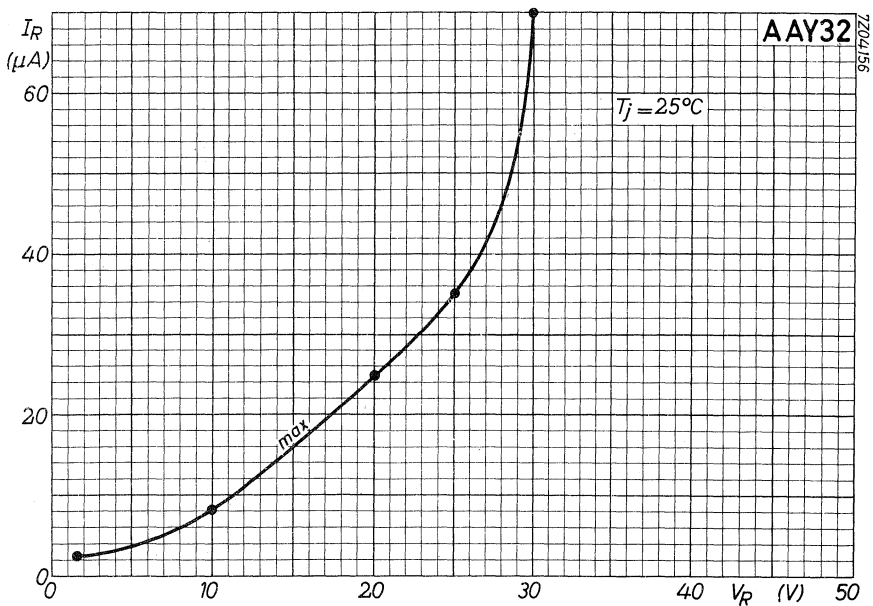
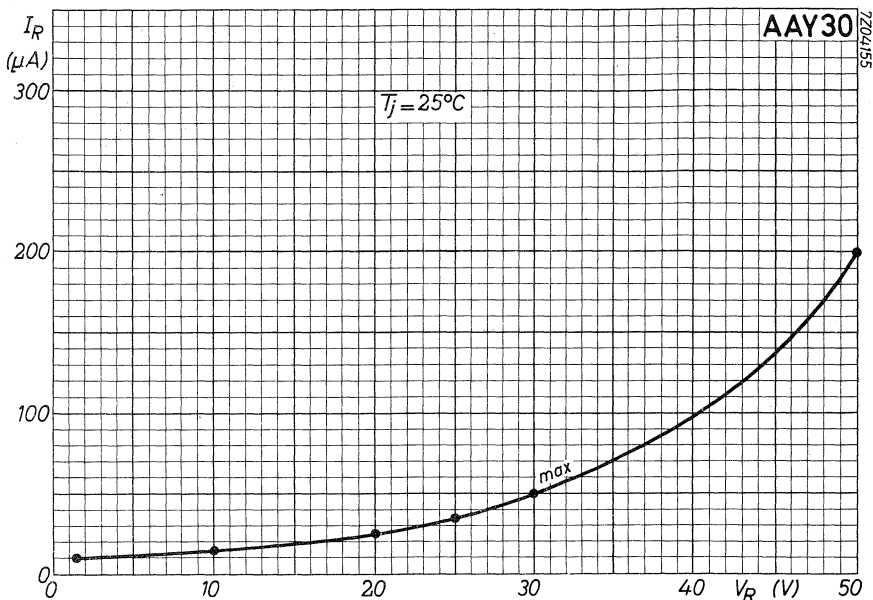

AAV30
AAV32

7204157
7204158
7204159
7204160
7204161
7204162

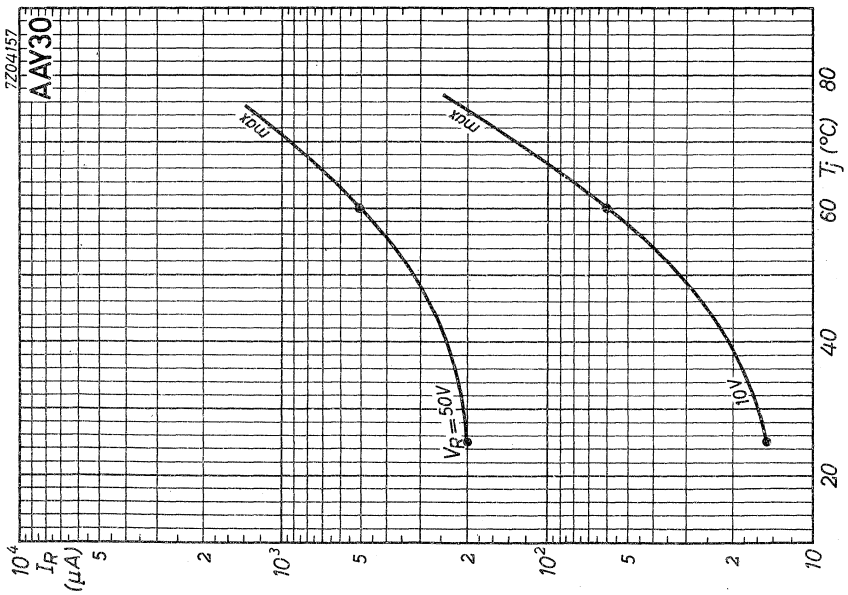
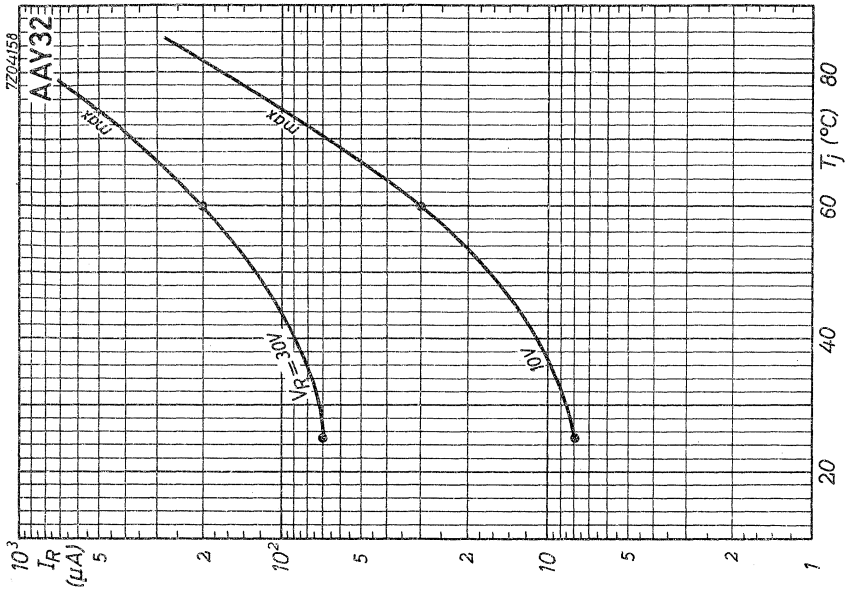

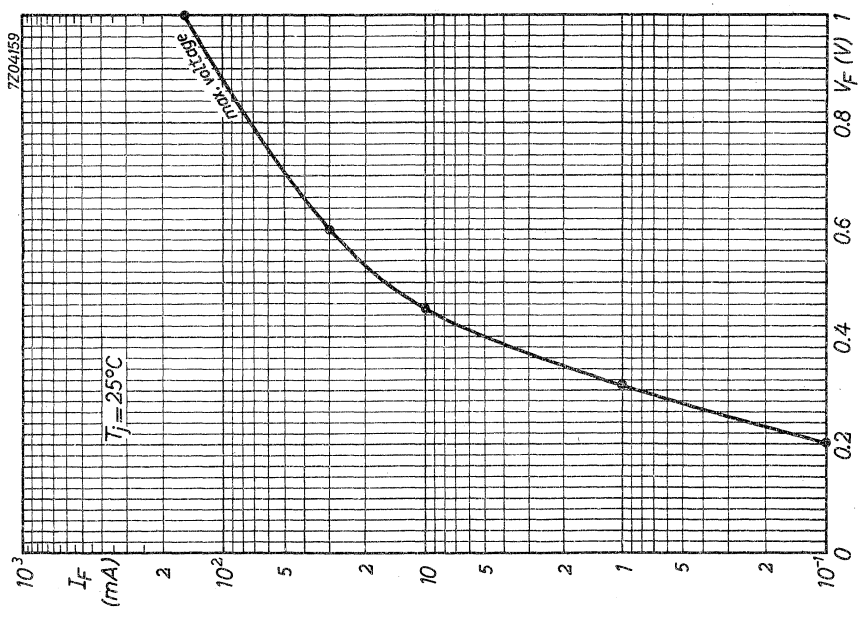

AA330
AA332

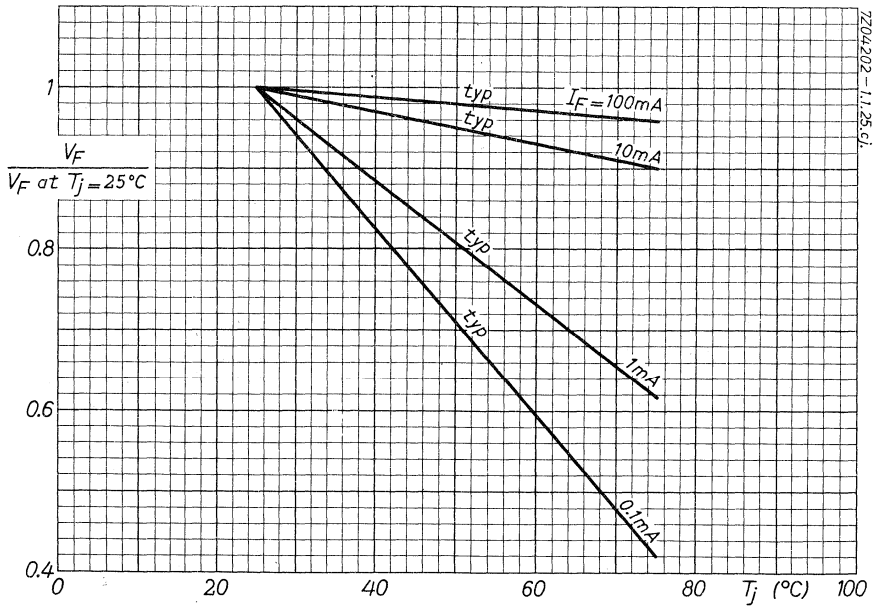
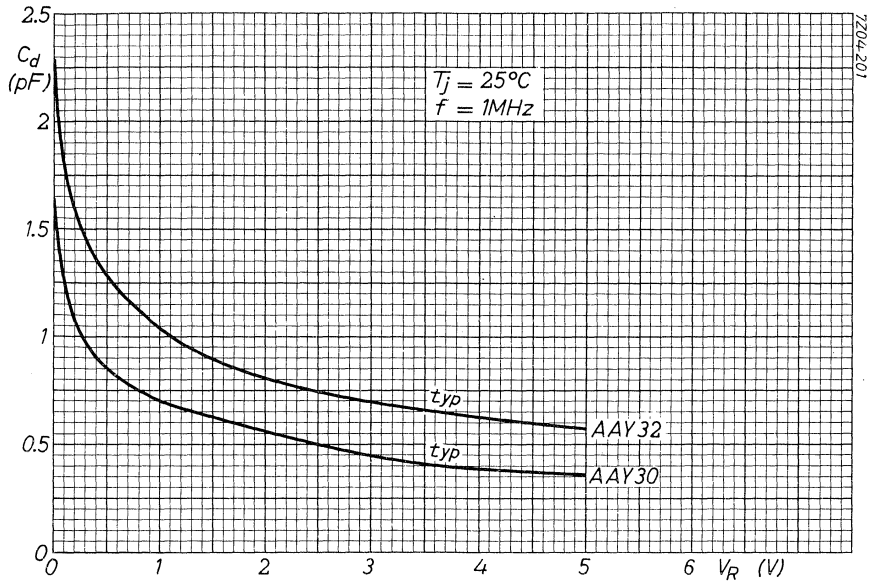

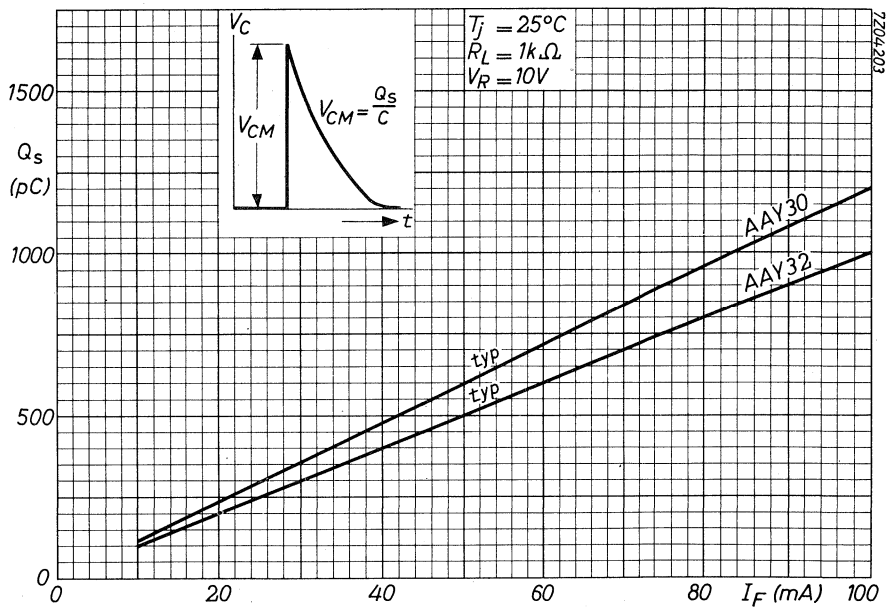

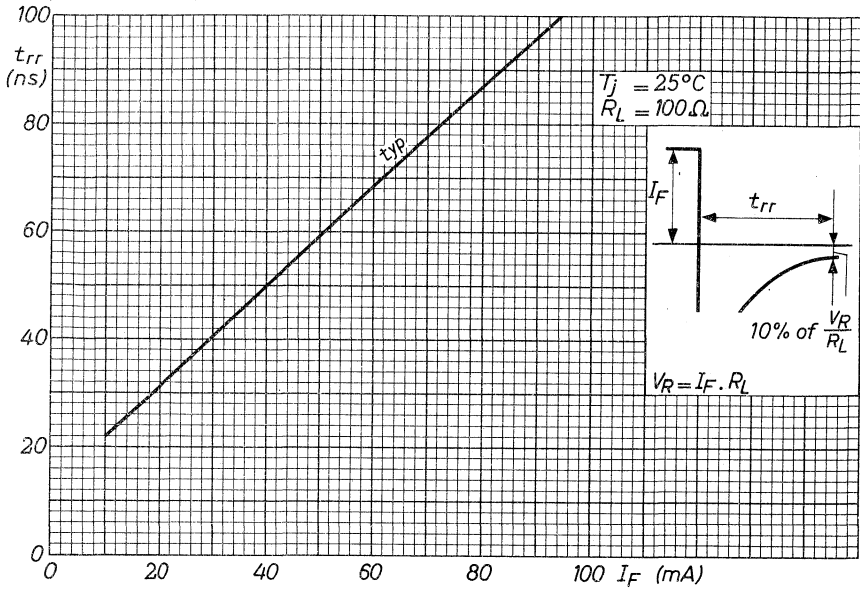

7204204-11.25°C

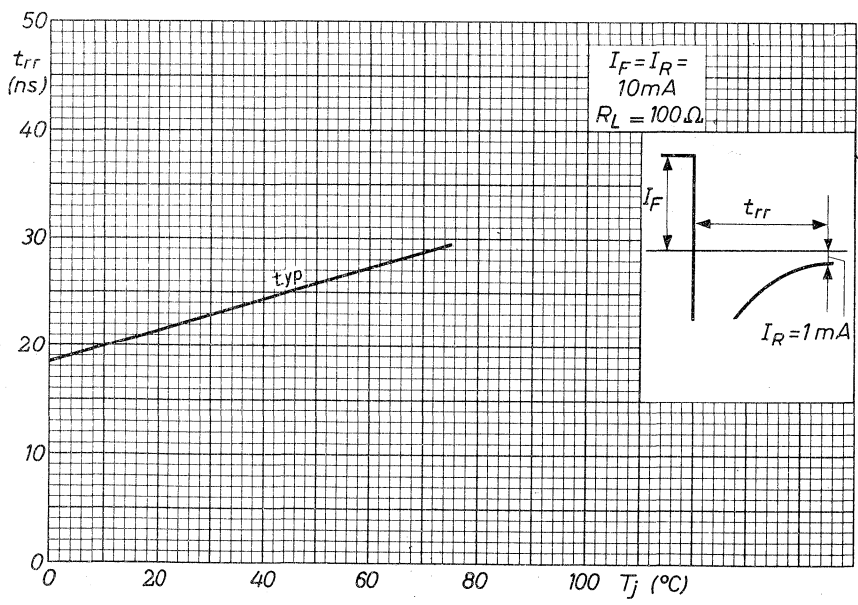

7204205-11.25°C

CHARACTERISTICS

→ $T_j = 25\text{ }^\circ\text{C}$ unless otherwise specifiedForward voltage

$I_F = 1\text{ mA}$

V_F	typ.	0,27	V
	<	0,32	V

$I_F = 10\text{ mA}$

V_F	typ.	0,50	V
	<	0,60	V

$I_F = 30\text{ mA}$

V_F	typ.	0,60	V
	<	1,00	V

Reverse current

$V_R = 3\text{ V}$

		$T_j = 25$		$60\text{ }^\circ\text{C}$	
I_R	typ.	5	30	μA	
	<	25	85	μA	

$V_R = 8\text{ V}$

I_R	typ.	30	190	μA	
	<	150	-	μA	

Diode capacitance

$V_R = 1\text{ V}$

C_d	typ.	3,3	pF
-------	------	-----	----

$V_R = 3\text{ V}$

C_d	typ.	1,3	pF
	<	2,0	pF

Forward recovery voltage

$I_F = 20\text{ mA}; t_r = 5\text{ ns}$

V_{fr}	typ.	0,7	V
	<	1,5	V

Recovery charge when switched from

$I_F = 10\text{ mA to } V_R = 5\text{ V}; R_L = 0,5\text{ k}\Omega; t_f = 5\text{ ns}$

Q_s	typ.	20	pC
	<	30	pC

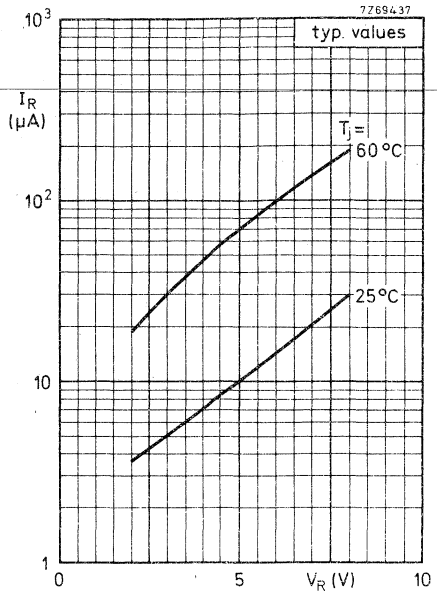
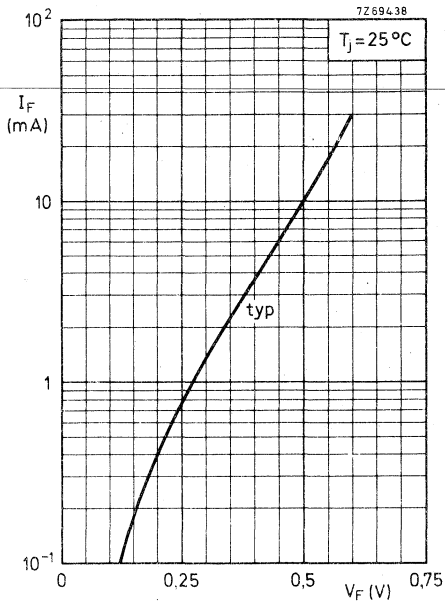

GOLD BONDED DIODES

Germanium diodes in all-glass DO-7 envelope, intended for switching applications and general purposes.

QUICK REFERENCE DATA				
		AAZ15		AAZ17
Continuous reverse voltage	V_R	max.	75	50 V
Repetitive peak reverse voltage	V_{RRM}	max.	100	75 V
Forward current (d. c.)	I_F	max.	140	140 mA
Repetitive peak forward current	I_{FRM}	max.	250	250 mA
Junction temperature	T_j	max.	85	85 °C
Forward voltage at $I_F = 250$ mA	V_F	<	1,1	1,1 V
Recovery charge when switched from $I_F = 10$ mA to $V_R = 10$ V	Q_S	<	1800	900 pC

MECHANICAL DATA

Dimensions in mm

DO-7

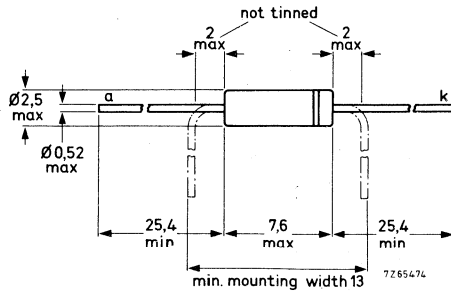

The coloured band indicates the cathode

RATINGS Limiting values in accordance with the Absolute Maximum System (IEC134)

Voltages

		AAZ15	AAZ17
Continuous reverse voltage	V_R	max. 75	50 V
Repetitive peak reverse voltage	V_{RRM}	max. 100	75 V
Non-repetitive peak reverse voltage ($t < 1$ s)	V_{RSM}	max. 115	75 V

Currents

Forward current (d.c.)	I_F	max. 140	mA
Average rectified forward current (averaged over any 20 ms period)	$I_{F(AV)}$	max. 140	mA
Repetitive peak forward current	I_{FRM}	max. 250	mA
Non-repetitive peak forward current ($t < 1$ s)	I_{FSM}	max. 500	mA

Temperatures

Storage temperature	T_{stg}	-65 to +85	°C
Junction temperature	T_j	max. 85	°C

THERMAL RESISTANCE

From junction to ambient in free air	$R_{th j-a}$	=	0.55	°C/mW
--------------------------------------	--------------	---	------	-------

CHARACTERISTICS

Forward voltage at $T_j = 25\text{ }^\circ\text{C}$

$I_F = 0,1\text{ mA}$

$V_F < 0,20\text{ V}$

$I_F = 10\text{ mA}$

$V_F < 0,45\text{ V}$

$I_F = 250\text{ mA}$

$V_F < 1,10\text{ V}$

Forward voltage at $T_j = 60\text{ }^\circ\text{C}$

$I_F = 0,1\text{ mA}$

$V_F < 0,15\text{ V}$

$I_F = 10\text{ mA}$

$V_F < 0,40\text{ V}$

$I_F = 250\text{ mA}$

$V_F < 1,07\text{ V}$

Reverse current at $T_j = 25\text{ }^\circ\text{C}$

$V_R = 1,5\text{ V}$

	AAZ15	AAZ17
I_R	$< 2,5$	$2,5\text{ }\mu\text{A}$
I_R	< 4	$15\text{ }\mu\text{A}$
I_R	< 15	$150\text{ }\mu\text{A}$
I_R	< 25	$300\text{ }\mu\text{A}$
I_R	< 100	$-\text{ }\mu\text{A}$

$V_R = 10\text{ V}$

$I_R < 4$

$V_R = 50\text{ V}$

$I_R < 15$

$V_R = 75\text{ V}$

$I_R < 25$

$V_R = 100\text{ V}$

$I_R < 100$

Reverse current at $T_j = 60\text{ }^\circ\text{C}$

$V_R = 1,5\text{ V}$

$I_R < 30$

$V_R = 10\text{ V}$

$I_R < 40$

$V_R = 50\text{ V}$

$I_R < 80$

$V_R = 75\text{ V}$

$I_R < 120$

$V_R = 100\text{ V}$

$I_R < 300$

Diode capacitance at $T_j = 25\text{ }^\circ\text{C}$

$V_R = 1\text{ V}; f = 1\text{ MHz}$

$C_d < 2$

AAZ15 AAZ17

→ CHARACTERISTICS (continued)

$T_j = 25\text{ }^\circ\text{C}$

Reverse recovery time when switched from

$$I_F = 10\text{ mA to } I_R = 10\text{ mA}; R_L = 100\ \Omega;$$

measured at $I_R = 1\text{ mA}$

AAZ15	t_{rr}	typ.	350	ns
AAZ17	t_{rr}	<	350	ns

Test circuit and waveforms :

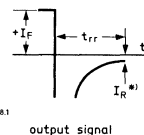
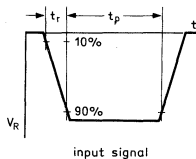
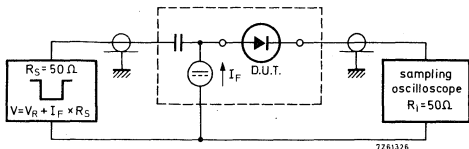

Input signal : Rise time of the reverse pulse

$$t_r = 0,6\text{ ns}$$

*) $I_R = 1\text{ mA}$

Reverse pulse duration

$$t_p = 500\text{ ns}$$

Duty factor

$$\delta = 0,05$$

Oscilloscope : Rise time

$$t_r = 0,35\text{ ns}$$

Circuit capacitance $C \leq 1\text{ pF}$ ($C =$ oscilloscope input capacitance + parasitic capacitance)

Recovery charge when switched from

$$I_F = 10\text{ mA to } V_R = 10\text{ V}; R_L = 1\text{ k}\Omega$$

AAZ15	Q_S	<	1800	pC
AAZ17	Q_S	<	900	pC

Test circuit and waveform :

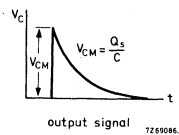
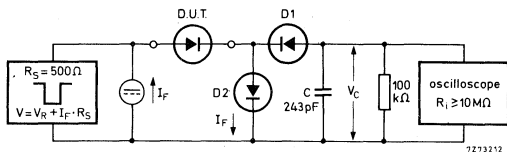

D1 = D2 = BAW62

Input signal : Rise time of the reverse pulse

$$t_r = 2\text{ ns}$$

Reverse pulse duration

$$t_p = 400\text{ ns}$$

Duty factor

$$\delta = 0,02$$

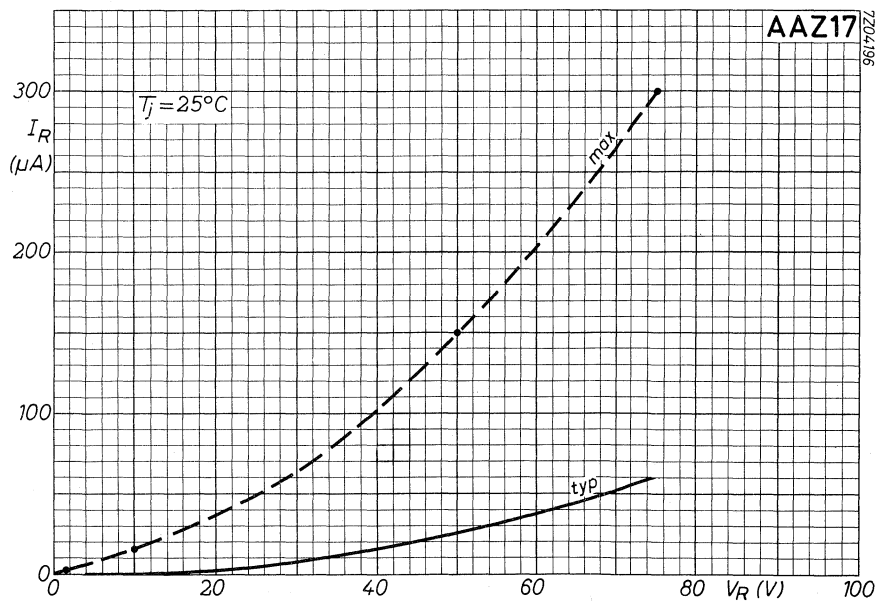
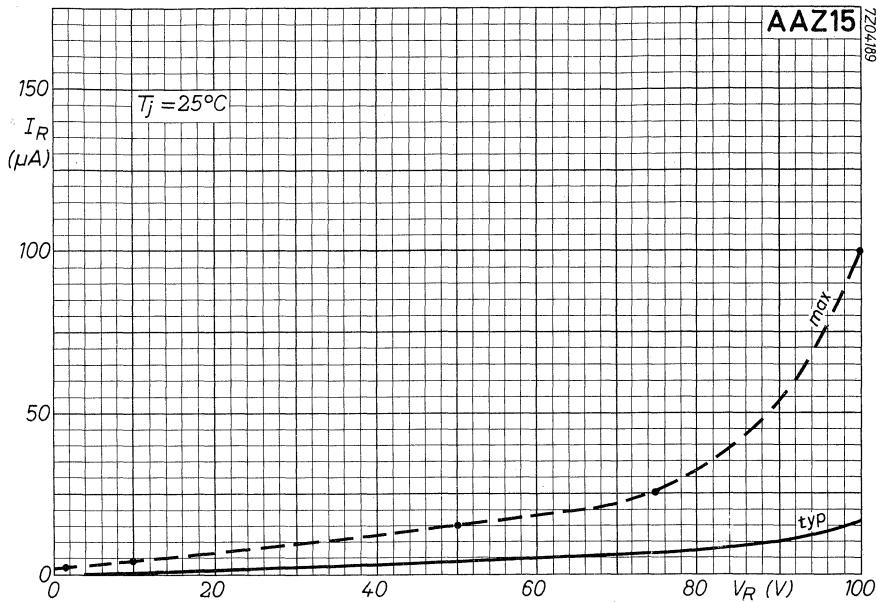

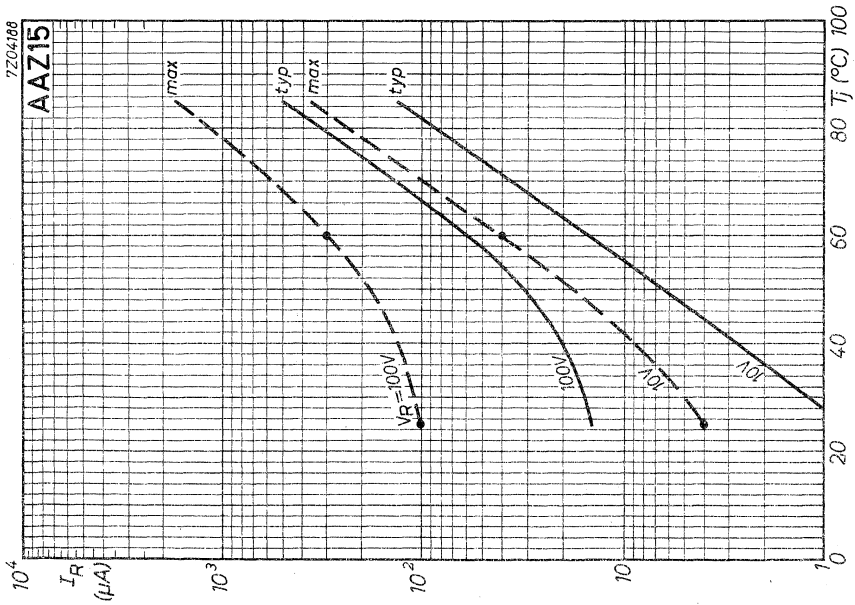
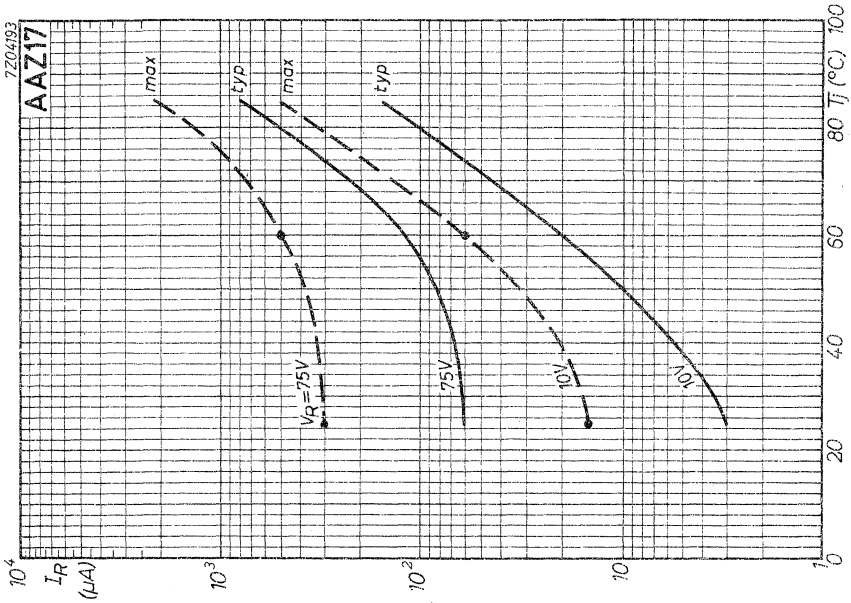

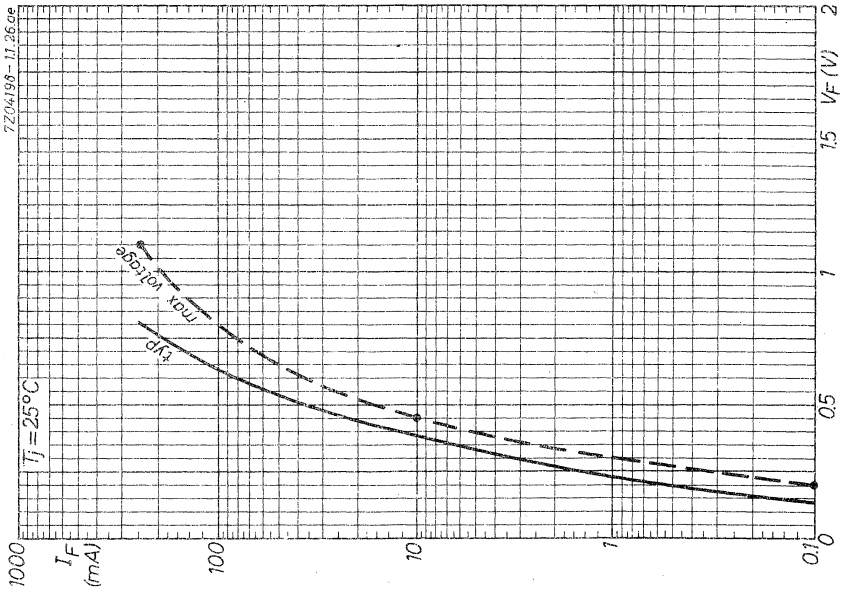

**AAZ15
AAZ17**

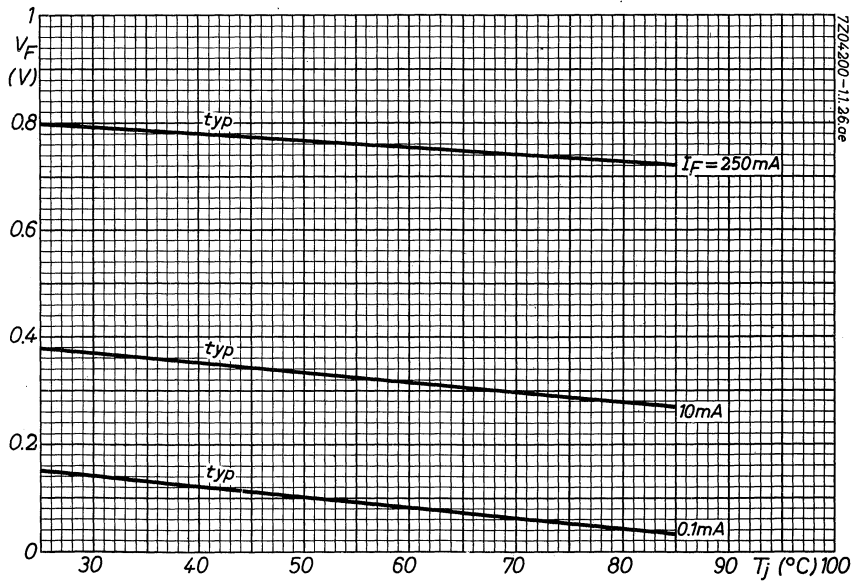
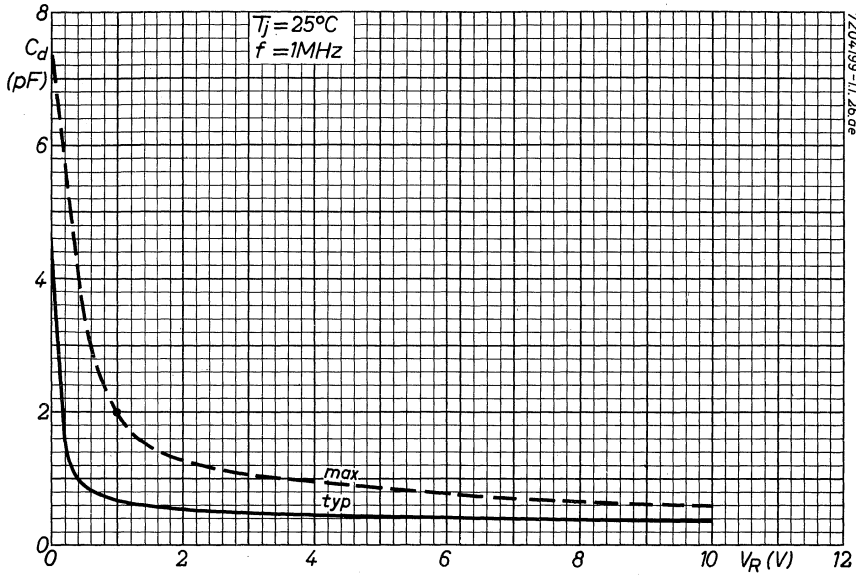

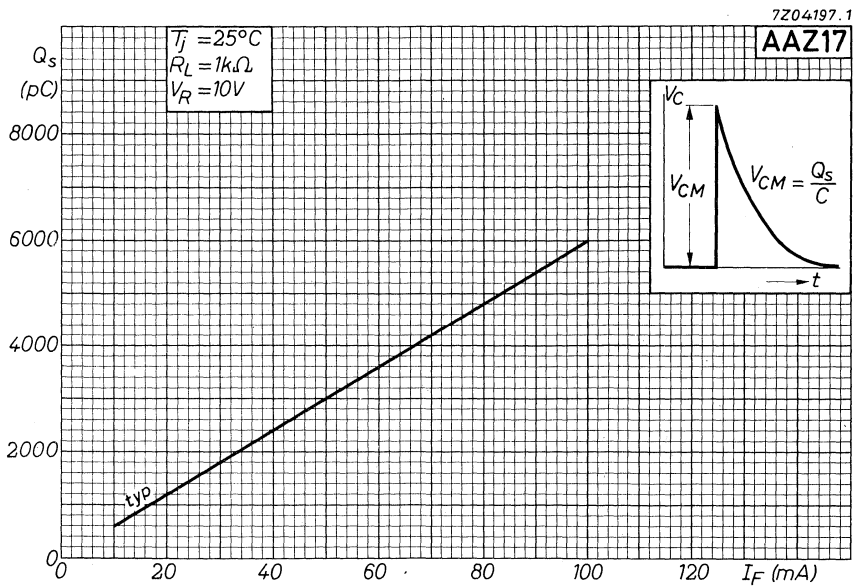
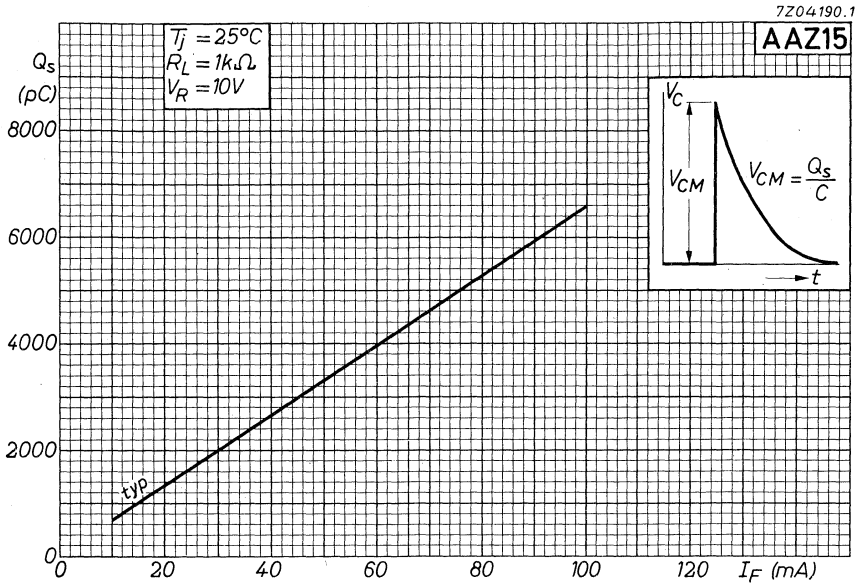

AAZ15
AAZ17

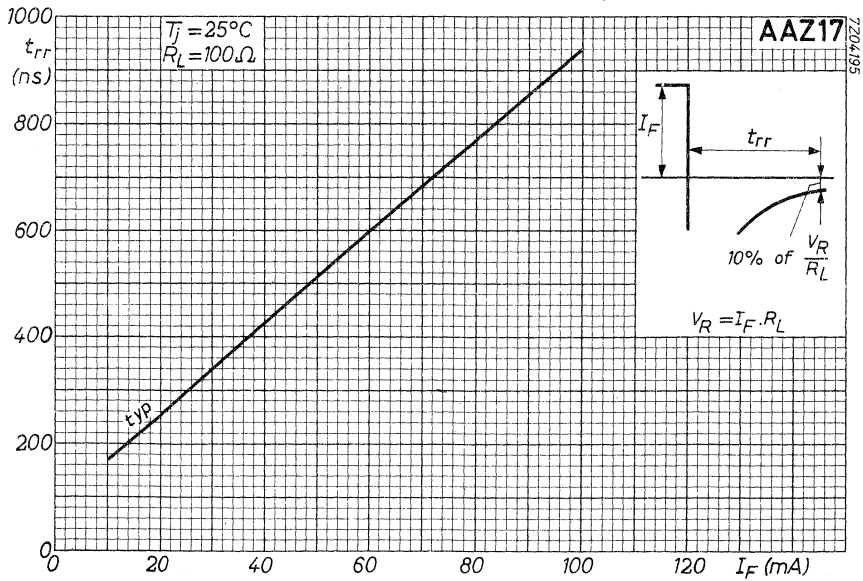
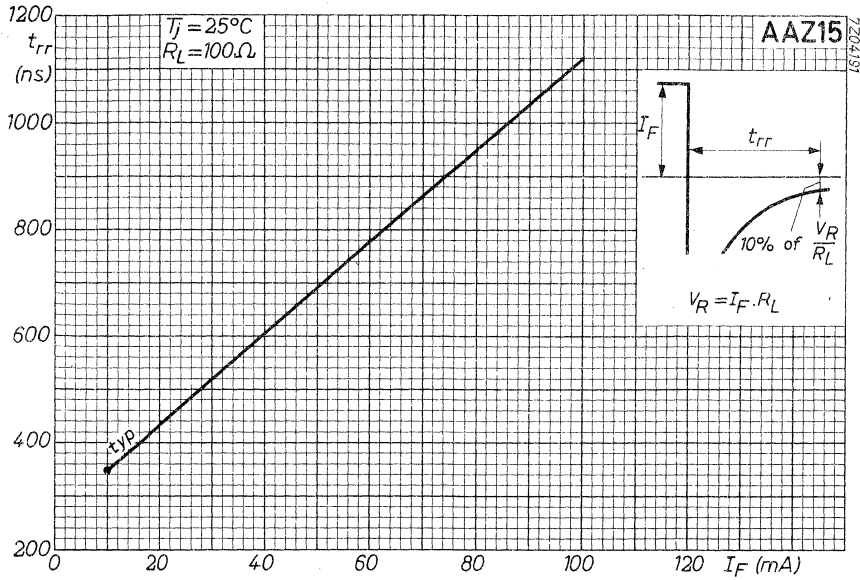

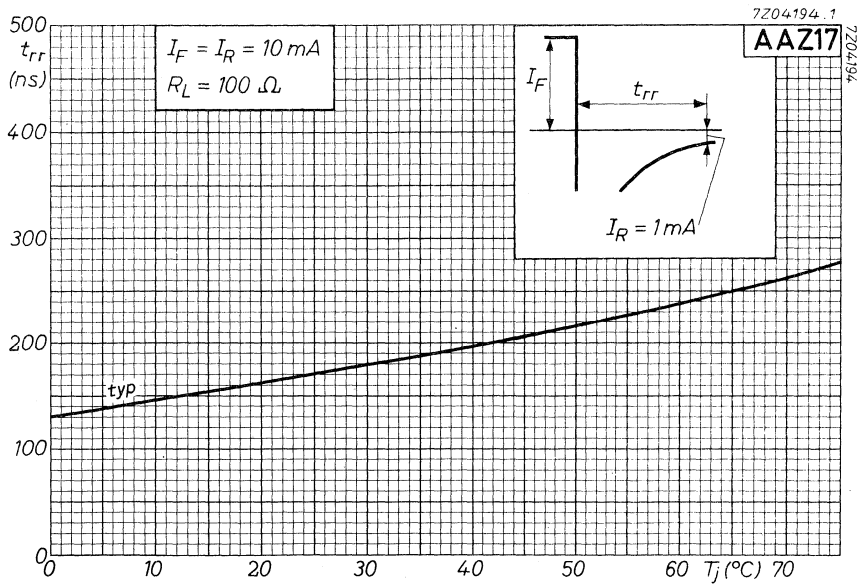
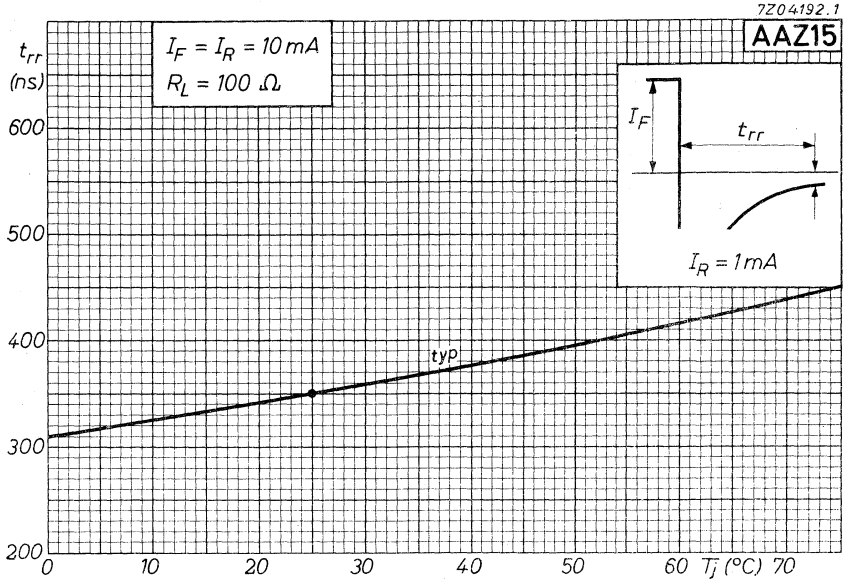

GOLD BONDED DIODE

Germanium diode in all-glass DO-7 envelope, intended for switching applications and general purposes.

QUICK REFERENCE DATA			
Continuous reverse voltage	V_R	max.	20 V
Repetitive peak reverse voltage	V_{RRM}	max.	20 V
Forward current (d.c.)	I_F	max.	130 mA
Repetitive peak forward current	I_{FRM}	max.	300 mA
Junction temperature	T_j	max.	75 °C
Forward voltage at $I_F = 300$ mA	V_F	<	1.0 V

MECHANICAL DATA

Dimensions in mm

DO-7

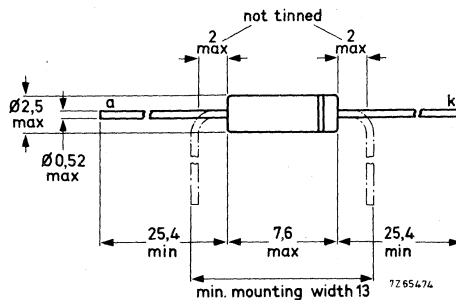

The coloured band indicates the cathode

RATINGS Limiting values in accordance with the Absolute Maximum System (IEC 134)Voltages

Continuous reverse voltage	V_R	max.	20 V
Repetitive peak reverse voltage	V_{RRM}	max.	20 V
Non repetitive peak reverse voltage ($t < 1$ s)	V_{RSM}	max.	30 V

Currents

Forward current (d.c.)	I_F	max.	130 mA
Average rectified forward current (averaged over any 20 ms period)	I_{FAV}	max.	130 mA
Repetitive peak forward current	I_{FRM}	max.	300 mA
Non repetitive peak forward current ($t < 1$ s)	I_{FSM}	max.	400 mA

Temperatures

Storage temperature	T_{stg}	-65 to +75 °C
Junction temperature	T_j	max. 75 °C

THERMAL RESISTANCE

From junction to ambient in free air	R_{thj-a}	=	0.55 °C/mW
--------------------------------------	-------------	---	------------

CHARACTERISTICS

Forward voltage at $T_j = 25\text{ }^\circ\text{C}$

$$I_F = 0,1\text{ mA}$$

$$V_F < 0,20\text{ V}$$

$$I_F = 1,0\text{ mA}$$

$$V_F < 0,30\text{ V}$$

$$I_F = 10\text{ mA}$$

$$V_F < 0,42\text{ V}$$

$$I_F = 30\text{ mA}$$

$$V_F < 0,50\text{ V}$$

$$I_F = 150\text{ mA } 1)$$

$$V_F < 0,75\text{ V}$$

$$I_F = 300\text{ mA } 1)$$

$$V_F < 1,00\text{ V}$$

Forward voltage at $T_j = 60\text{ }^\circ\text{C}$

$$I_F = 0,1\text{ mA}$$

$$V_F < 0,14\text{ V}$$

$$I_F = 1,0\text{ mA}$$

$$V_F < 0,25\text{ V}$$

$$I_F = 10\text{ mA}$$

$$V_F < 0,38\text{ V}$$

$$I_F = 30\text{ mA}$$

$$V_F < 0,48\text{ V}$$

$$I_F = 150\text{ mA } 1)$$

$$V_F < 0,75\text{ V}$$

Reverse current at $T_j = 25\text{ }^\circ\text{C}$

$$V_R = 1,5\text{ V}$$

$$I_R < 3,5\text{ }\mu\text{A}$$

$$V_R = 10\text{ V}$$

$$I_R < 15\text{ }\mu\text{A}$$

$$V_R = 20\text{ V}$$

$$I_R < 50\text{ }\mu\text{A}$$

Reverse current at $T_j = 60\text{ }^\circ\text{C}$

$$V_R = 1,5\text{ V}$$

$$I_R < 30\text{ }\mu\text{A}$$

$$V_R = 10\text{ V}$$

$$I_R < 45\text{ }\mu\text{A}$$

$$V_R = 20\text{ V}$$

$$I_R < 100\text{ }\mu\text{A}$$

Diode capacitance at $T_j = 25\text{ }^\circ\text{C}$

$$V_R = 1\text{ V}; f = 1\text{ MHz}$$

$$C_d < 2,5\text{ pF}$$

1) Measured under pulse conditions to avoid excessive dissipation.

CHARACTERISTICS (continued)

$T_j = 25\text{ }^\circ\text{C}$

→ Reverse recovery time when switched from

$I_F = 10\text{ mA}$ to $I_R = 10\text{ mA}$; $R_L = 100\text{ }\Omega$;

measured at $I_R = 1\text{ mA}$

$t_{rr} < 70\text{ ns}$

Test circuit and waveforms :

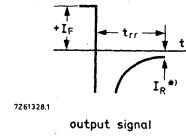
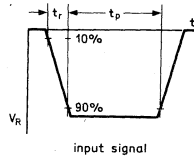
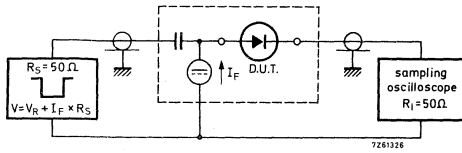

Input signal : Rise time of the reverse pulse

$t_r = 0,6\text{ ns}$

*) $I_R = 1\text{ mA}$

Reverse pulse duration

$t_p = 100\text{ ns}$

Duty factor

$\delta = 0,05$

Oscilloscope : Rise time

$t_r = 0,35\text{ ns}$

Circuit capacitance $C \leq 1\text{ pF}$ ($C =$ oscilloscope input capacitance + parasitic capacitance)

GOLD BONDED DIODE

Germanium diode in all-glass DO-7 envelope, intended for switching applications and general purposes.

QUICK REFERENCE DATA			
Continuous reverse voltage	V_R	max.	25 V
Repetitive peak reverse voltage	V_{RRM}	max.	25 V
Forward current (d. c.)	I_F	max.	110 mA
Repetitive peak forward current	I_{FRM}	max.	150 mA
Junction temperature	T_j	max.	75 °C
Forward voltage at $I_F = 150$ mA	V_F	<	1,1 V
Recovery charge when switched from $I_F = 10$ mA to $V_R = 10$ V	Q_s	<	600 pC

MECHANICAL DATA

Dimensions in mm

DO-7

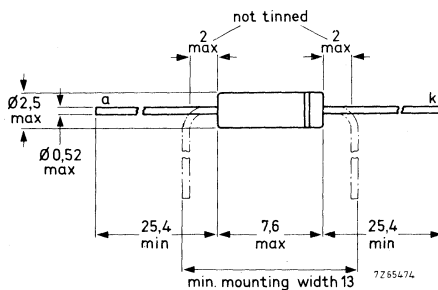

The coloured band indicates the cathode

RATINGS Limiting values in accordance with the Absolute Maximum System (IEC134)

Voltages

Continuous reverse voltage	V_R	max.	25 V
Repetitive peak reverse voltage	V_{RRM}	max.	25 V
Non-repetitive peak reverse voltage ($t < 1$ s)	V_{RSM}	max.	30 V

Currents

Forward current (d.c.)	I_F	max.	110 mA
Average rectified forward current (averaged over any 20 ms period)	$I_{F(AV)}$	max.	110 mA
Repetitive peak forward current	I_{FRM}	max.	150 mA
Non-repetitive peak forward current ($t < 1$ s)	I_{FSM}	max.	200 mA

Temperatures

Storage temperature	T_{stg}	-65 to +75 °C
Junction temperature	T_j	max. 75 °C

THERMAL RESISTANCE

From junction to ambient in free air	R_{thj-a}	=	0.55 °C/mW
--------------------------------------	-------------	---	------------

CHARACTERISTICS

Forward voltage at $T_j = 25\text{ }^\circ\text{C}$

$I_F = 0,1\text{ mA}$	$V_F < 0,20\text{ V}$
$I_F = 1,0\text{ mA}$	$V_F < 0,31\text{ V}$
$I_F = 10\text{ mA}$	$V_F < 0,45\text{ V}$
$I_F = 30\text{ mA}$	$V_F < 0,65\text{ V}$
$I_F = 150\text{ mA}$	$V_F < 1,10\text{ V}$

Forward voltage at $T_j = 60\text{ }^\circ\text{C}$

$I_F = 0,1\text{ mA}$	$V_F < 0,14\text{ V}$
$I_F = 1,0\text{ mA}$	$V_F < 0,28\text{ V}$
$I_F = 10\text{ mA}$	$V_F < 0,43\text{ V}$
$I_F = 30\text{ mA}$	$V_F < 0,62\text{ V}$
$I_F = 150\text{ mA}$	$V_F < 1,10\text{ V}$

Reverse current at $T_j = 25\text{ }^\circ\text{C}$

$V_R = 1,5\text{ V}$	$I_R < 3,5\text{ }\mu\text{A}$
$V_R = 10\text{ V}$	$I_R < 15\text{ }\mu\text{A}$
$V_R = 20\text{ V}$	$I_R < 50\text{ }\mu\text{A}$
$V_R = 25\text{ V}$	$I_R < 100\text{ }\mu\text{A}$

Reverse current at $T_j = 60\text{ }^\circ\text{C}$

$V_R = 1,5\text{ V}$	$I_R < 20\text{ }\mu\text{A}$
$V_R = 10\text{ V}$	$I_R < 40\text{ }\mu\text{A}$
$V_R = 20\text{ V}$	$I_R < 90\text{ }\mu\text{A}$
$V_R = 25\text{ V}$	$I_R < 160\text{ }\mu\text{A}$

Diode capacitance at $T_j = 25\text{ }^\circ\text{C}$

$V_R = 1\text{ V}; f = 1\text{ MHz}$	$C_d < 3,5\text{ pF}$
--------------------------------------	-----------------------

→ CHARACTERISTICS (continued)

$T_j = 25\text{ }^\circ\text{C}$

Reverse recovery time when switched from

$I_F = 10\text{ mA}$ to $I_R = 10\text{ mA}$; $R_L = 100\text{ }\Omega$;

measured at $I_R = 1\text{ mA}$

$t_{rr} < 70\text{ ns}$

Test circuit and waveforms :

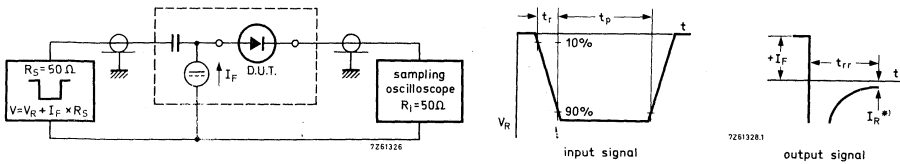

Input signal : Rise time of the reverse pulse

$t_r = 0,6\text{ ns}$

*) $I_R = 1\text{ mA}$

Reverse pulse duration

$t_p = 100\text{ ns}$

Duty factor

$\delta = 0,05$

Oscilloscope : Rise time

$t_r = 0,35\text{ ns}$

Circuit capacitance $C \leq 1\text{ pF}$ ($C =$ oscilloscope input capacitance + parasitic capacitance)

Recovery charge when switched from

$I_F = 10\text{ mA}$ to $V_R = 10\text{ V}$; $R_L = 1\text{ k}\Omega$

$Q_S < 600\text{ pC}$

Test circuit and waveform :

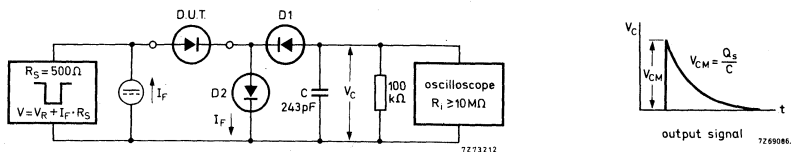

$D1 = D2 = \text{BAW62}$

Input signal : Rise time of the reverse pulse

$t_r = 2\text{ ns}$

Reverse pulse duration

$t_p = 400\text{ ns}$

Duty factor

$\delta = 0,02$

Silicon small signal diodes

Alloyed



ALLOYED DIODES

Silicon diodes in DO-7 envelope

Quoted values are max.

general purpose

type	V_R (V)	I_F (mA)	I_{FRM} (mA)	C_d (pF)	V_F at I_F (V)	I_F (mA)
BA100	60	90	100	—	1,5	30
OA200	50	160	250	25	1,15	30
OA202	150	160	250	25	1,15	30

MECHANICAL DATA

Dimensions in mm

DO-7

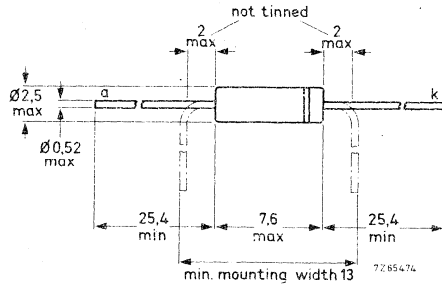

Cathode indicated by coloured band

SILICON DIODE

General purpose diode in all-glass DO-7 envelope.

MECHANICAL DATA

Dimensions in mm

DO-7

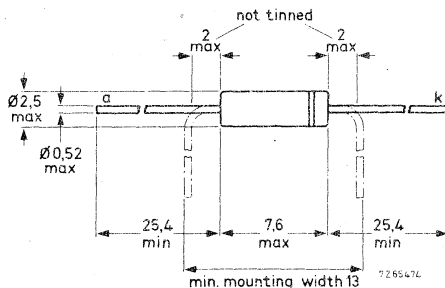

The coloured band indicates the cathode

RATINGS Limiting values in accordance with the Absolute Maximum System (IEC134)

Voltage

Continuous reverse voltage V_R max. 60 V

Currents

Forward current (d.c.) I_F max. 90 mA

Repetitive peak forward current I_{FRM} max. 100 mA

Non-repetitive peak forward current ($t \leq 1$ s) I_{FSM} max. 200 mA

Temperatures

Storage temperature T_{stg} -55 to +90 °C

Junction temperature T_j max. 90 °C

THERMAL RESISTANCE

From junction to ambient in free air $R_{th\ j-a} = 0.4$ °C/mW

CHARACTERISTICS

Forward voltage

$I_F = 0.1$ mA

	$T_{amb} = 25$ °C	$T_{amb} = 60$ °C
V_F	typ. 0.55 < 0.75	typ. 0.5 V V

$I_F = 1.0$ mA

V_F	typ. 0.65 0.5 to 1.0	typ. 0.6 V 0.4 to 0.9 V
-------	-------------------------	----------------------------

$I_F = 30$ mA

V_F	typ. 0.9 < 1.5	typ. 0.85 V < 1.5 V
-------	-------------------	------------------------

Reverse current

$V_R = 10$ V

	$T_{amb} = 60$ °C	$T_{amb} = 75$ °C
I_R	typ. 5.0	< 10 μ A

$V_R = 60$ V

I_R	typ. 10	< 20 μ A
-------	---------	--------------

SILICON DIODES

Silicon alloyed general purpose diodes in all-glass DO-7 envelopes.

QUICK REFERENCE DATA				
		OA200		OA202
Continuous reverse voltage	V_R	max.	50	150 V
Repetitive peak forward current	I_{FRM}	max.	250 mA	
Thermal resistance from junction to ambient	$R_{th j-a}$	=	0,4 °C/mW	
Forward voltage $I_F = 30 \text{ mA}; T_{amb} = 25 \text{ °C}$	V_F	typ.	0,9 V	
Reverse recovery time when switched from $I_F = 30 \text{ mA}$ to $V_R = 35 \text{ V}$; $R_L = 2,5 \text{ k}\Omega$; measured at $I_R = 4 \text{ mA}$	t_{rr}	typ.	3,5 μs	

MECHANICAL DATA

Dimensions in mm

DO-7

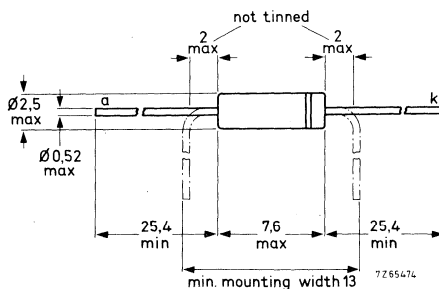

The coloured band indicates the cathode

RATINGS (Limiting values) ¹⁾

Voltage

Continuous reverse voltage	OA200	V_R	max.	50	V
	OA202	V_R	max.	150	V

Currents

		$T_{amb} = 25\text{ }^\circ\text{C}$	$T_{amb} = 125\text{ }^\circ\text{C}$
Average rectified forward current (averaged over any 20 ms period)	$I_{F(AV)}$	max. 160	48 mA
Average forward current for sinusoidal operation	$I_{F(AV)}$	max. 80	40 mA
Forward current (d. c. ; see page 4)	I_F	max. 160	48 mA
Repetitive peak forward current	I_{FRM}	max. 250	125 mA

Temperatures

Storage temperature	T_{stg}	-55 °C to +125	°C
→ Operating junction temperature	T_j	max. 150	°C

THERMAL RESISTANCE

From junction to ambient in free air	$R_{th\ j-a}$	=	0,4	°C/mW
--------------------------------------	---------------	---	-----	-------

CHARACTERISTICS

Forward voltage

		$T_{amb} = 25\text{ }^\circ\text{C}$	$T_{amb} = 125\text{ }^\circ\text{C}$
$I_F = 0,1\text{ mA}$	V_F	typ. 0,52	- V
		< 0,62	0,30 V
$I_F = 10\text{ mA}$	V_F	typ. 0,80	- V
		< 0,96	0,65 V
$I_F = 30\text{ mA}$	V_F	typ. 0,90	- V
		< 1,15	0,80 V

Reverse current

$V_R = V_{Rmax}$	OA200	I_R	typ. 0,02	1 μA
			< 0,10	10 μA
	OA202	I_R	typ. 0,01	0,5 μA
			< 0,10	10 μA

Diode capacitance at $T_{amb} = 25\text{ }^\circ\text{C}$

$V_R = 0,75\text{ V}; f = 0,5\text{ MHz}$	C_d	typ.	10	pF
		<	25	pF

¹⁾ Limiting values according to the Absolute Maximum System as defined in IEC publication 134.

CHARACTERISTICS (continued)

$T_{amb} = 25\text{ }^{\circ}\text{C}$

Reverse recovery current when switched from

$I_F = 5\text{ mA}$ to $V_R = 5\text{ V}$; $R_L = 2.5\text{ k}\Omega$
 measured at $t_{rr} = 3.5\text{ }\mu\text{s}$
 $t_{rr} = 10\text{ }\mu\text{s}$

I_R typ. 1.2 mA
 I_R typ. $35\text{ }\mu\text{A}$

Reverse recovery current when switched from

$I_F = 30\text{ mA}$ to $V_R = 35\text{ V}$; $R_L = 2.5\text{ k}\Omega$
 measured at $t_{rr} = 3.5\text{ }\mu\text{s}$
 $t_{rr} = 10\text{ }\mu\text{s}$

I_R typ. 4 mA
 I_R typ. $230\text{ }\mu\text{A}$

Test circuit:

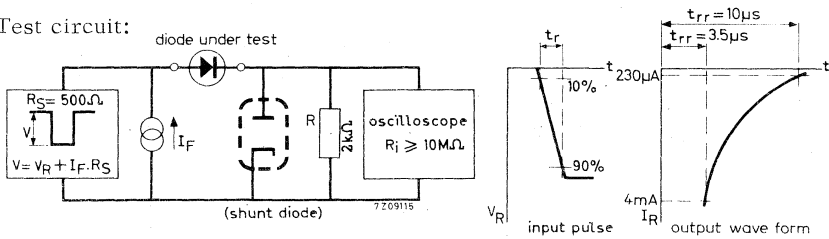

Reverse pulse: Rise time $t_r \leq 0.1\text{ }\mu\text{s}$
 Duty cycle $\delta = 0.5$
 Frequency $f = 50\text{ kHz}$

Oscilloscope: Capacitance $C = 40\text{ pF}$
 Rise time $t_r = 25\text{ ns}$

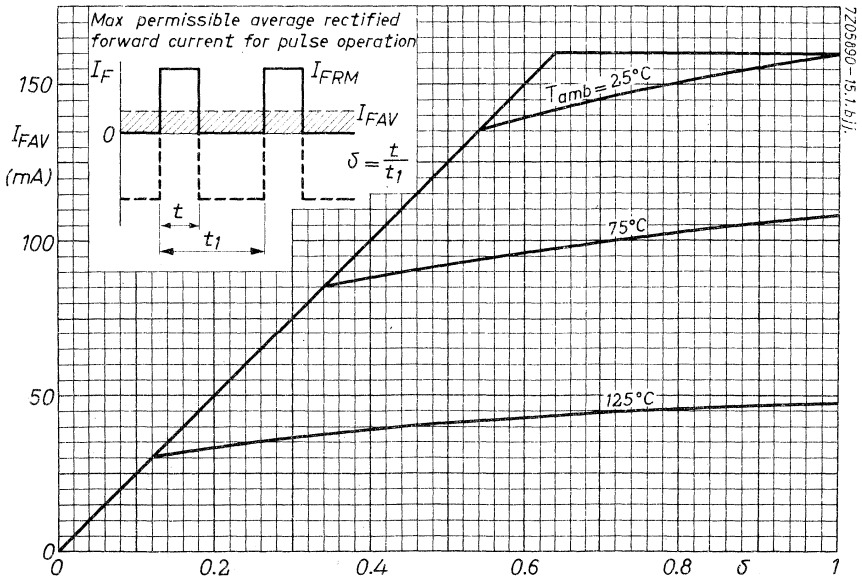

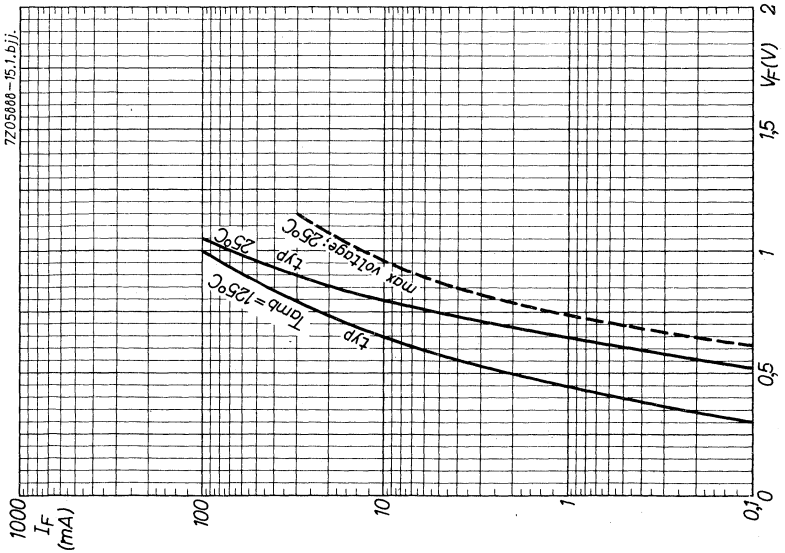
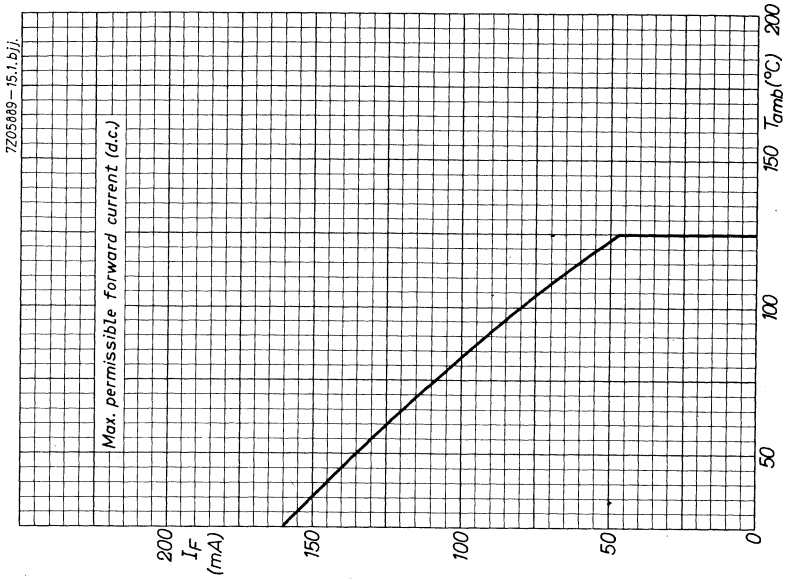

Silicon small signal diodes

Whiskerless



TYPE SELECTION

WHISKERLESS DIODES

Silicon diodes in DO-35 envelope

Quoted values are max.

	type	V_R (V)	I_F (mA)	I_{FRM} (mA)	t_{rr} (ns)	C_d (pF)	V_F at I_F (V)	I_F (mA)
general purpose	BA220	—	200	400	4	2,5	0,95	100
	BA221	30	200	400	4	2,5	1,05	200
	BA222	50	75	150	4	2	1,1	50
	BA316	10	100	225	4	3	1,1	100
	BA317	30	100	225	4	3	1,1	100
	BA318	50	100	225	4	3	1,1	100
high speed switching general purpose	BAW62	75	100	225	4	2	1	100
	1N4009	25	—	—	2	4	1	30
	1N4148	75	75	225	4	4	1	10
	1N4151	50	200	450	2	2	1	50
	1N4154	25	200	450	2	4	1	30
	1N4446	75	200	450	4	4	1	20
high speed core-gating	1N4448	75	200	450	4	4	1	100
	BAV10	60	300	600	6	2,5	1,25	500
high speed, high voltage	1N4150	50	300	600	6	2,5	1	200
	BAV18	50	250	625	50	5,0	1,25	200
	BAV19	100	250	625	50	5,0	1,25	200
	BAV20	150	250	625	50	5,0	1,25	200
	BAV21	200	250	625	50	5,0	1,25	200

MECHANICAL DATA

Dimensions in mm

DO-35

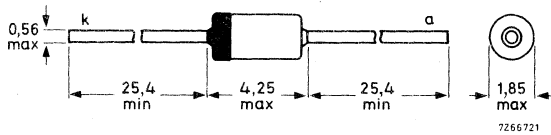

WHISKERLESS DIODES

Silicon diodes in SOD-17 envelope

Quoted values are max.

	type	V_R (V)	I_F (mA)	I_{FRM} (mA)	t_{rr} (ns)	C_d (pF)	V_F at I_F (V)	I_F (mA)
general purpose	BA216	—	75	150	4	3	1, 15	
	BA217	30	75	150	4	3	1, 50	
	BA218	50	75	150	4	3	1, 50	
	BA219	100	100	300	120	5	1, 100	
general industrial	BAX13	50	75	150	4	3	1, 53	75
	BAX14	20	500	2000	50	35	1, 1	300
	BAX15	150	250	500	300	20	1, 35	250
	BAX16	150	200	300	120	10	1, 5	200
	BAX17	200	200	300	120	10	1, 2	200
	BAX18	75	500	2000	—	—	1, 2	500
switching	1N914	75	75	225	4	4	1	10
	1N914A	75	75	225	4	4	1	20
	1N916	75	75	225	4	2	1	10
	1N916A	75	75	225	4	2	1	20
	1N916B	75	75	225	4	2	1	30
avalanche for telephony	BAX12	90	400	800	50	35	1, 25	400

MECHANICAL DATA

Dimensions in mm

SOD-17

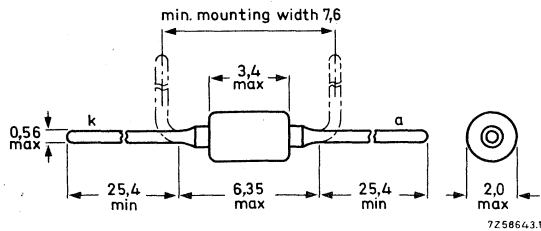

Cathode indicated by broad band
of colour code

SILICON OXIDE PASSIVATED DIODE

Whiskerless diode in a hard glass subminiature envelope. The diode is intended for low voltage regulation such as bias stabilizer in class-B output stages, clipping, clamping and meter protection.

QUICK REFERENCE DATA			
Repetitive peak reverse voltage	V_{RRM}	max.	10 V
Repetitive peak forward current	I_{FRM}	max.	150 mA
Storage temperature	T_{stg}		-65 to +200 °C
Junction temperature	T_j	max.	200 °C
Thermal resistance from junction to ambient	$R_{th\ j-a}$	=	0,60 °C/mW
Forward voltage at $I_F = 0,2$ mA	V_F		500 to 620 mV
	$I_F = 3,0$ mA	V_F	600 to 800 mV
	$I_F = 15$ mA	V_F	700 to 1000 mV
Temperature coefficient at $I_F = 3$ mA	S_F	typ.	-2 mV/°C
Reverse recovery time when switched from $I_F = 10$ mA to $I_R = 60$ mA; $R_L = 100 \Omega$; measured at $I_R = 1$ mA	t_{rr}	<	4 ns

MECHANICAL DATA

Dimensions in mm

SOD-17

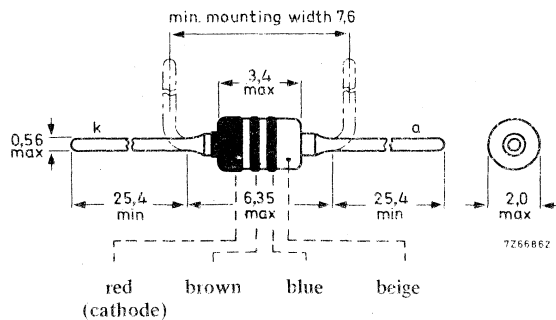

RATINGS Limiting values in accordance with the Absolute Maximum System (IEC134)

Voltage

Repetitive peak reverse voltage V_{RRM} max. 10 V

Currents

Average rectified forward current
(averaged over any 20 ms period) $I_{F(AV)}$ max. 75 mA ¹⁾

Forward current (d. c.) I_F max. 75 mA

Repetitive peak forward current I_{FRM} max. 150 mA

Non-repetitive peak forward current
 $t = 1 \mu s$ I_{FSM} max. 1000 mA
 $t = 1 s$ I_{FSM} max. 250 mA

Temperatures

Storage temperature T_{stg} -65 to +200 °C

Junction temperature T_j max. 200 °C

THERMAL RESISTANCE

From junction to ambient in free air $R_{th j-a}$ = 0,60 °C/mW

¹⁾ For sinusoidal operation $I_{F(AV)} = 48$ mA.

CHARACTERISTICS

$T_j = 25\text{ }^\circ\text{C}$

Forward voltage

$I_F = 0,2\text{ mA}$

$V_F = 700\text{ to }620\text{ mV}$

$I_F = 3,0\text{ mA}$

$V_F = 600\text{ to }800\text{ mV}$

$I_F = 15\text{ mA}$

$V_F = 700\text{ to }1000\text{ mV}$

Reverse current

$V_R = 10\text{ V}$

$I_R < 1500\text{ nA}$

Diode capacitance

$V_R = 0; f = 1\text{ MHz}$

$C_d < 3\text{ pF}$

Temperature coefficient

$I_F = 3\text{ mA}$

$S_F \text{ typ. } -2\text{ mV}/^\circ\text{C}$

Reverse recovery time when switched from

$I_F = 10\text{ mA}$ to $I_R = 60\text{ mA}; R_L = 100\text{ }\Omega$;

measured at $I_R = 1\text{ mA}$

$t_{rr} < 4\text{ ns}$

Test circuit and waveforms:

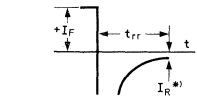
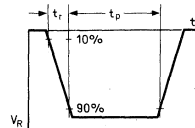
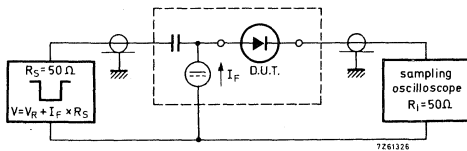

Input signal : Rise time of the reverse pulse

$t_r = 0,6\text{ ns}$

*) $I_R = 1\text{ mA}$

Reverse pulse duration

$t_p = 100\text{ ns}$

Duty factor

$\delta = 0,05$

Oscilloscope: Rise time

$t_r = 0,35\text{ ns}$

Circuit capacitance $C \leq 1\text{ pF}$ ($C =$ oscilloscope input capacitance + parasitic capacitance)

SILICON OXIDE PASSIVATED DIODE

Whiskerless diode in a hard glass subminiature envelope. The diode is intended for general purpose consumer applications.

QUICK REFERENCE DATA			
Continuous reverse voltage	V_R	max.	30 V
Repetitive peak forward current	I_{FRM}	max.	150 mA
Storage temperature	T_{stg}	-65 to +200	°C
Junction temperature	T_j	max.	200 °C
Thermal resistance from junction to ambient	$R_{th j-a}$	=	0,60 °C/mW
Forward voltage at $I_F = 1$ mA	V_F	<	0,7 V
$I_F = 10$ mA	V_F	<	1,0 V
$I_F = 50$ mA	V_F	<	1,5 V
Reverse recovery time when switched from $I_F = 10$ mA to $I_R = 60$ mA; $R_L = 100 \Omega$; measured at $I_R = 1$ mA	t_{rr}	<	4 ns

MECHANICAL DATA

Dimensions in mm

SOD-17

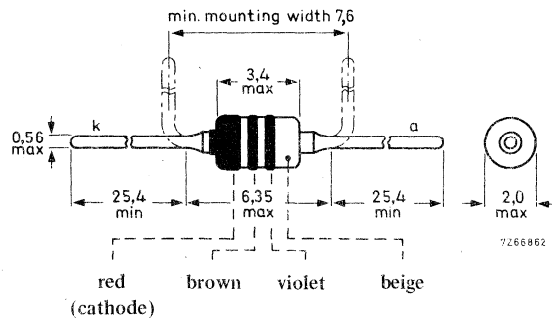

RATINGS Limiting values in accordance with the Absolute Maximum System (IEC 134)

Voltages

Continuous reverse voltage	V_R	max.	30	V
Repetitive peak reverse voltage	V_{RRM}	max.	30	V

Currents

Average rectified forward current (averaged over any 20 ms period)	$I_{F(AV)}$	max.	75	mA ¹⁾
Forward current (d. c.)	I_F	max.	75	mA
Repetitive peak forward current	I_{FRM}	max.	150	mA
Non-repetitive peak forward current t = 1 μ s	I_{FSM}	max.	2000	mA
t = 1 s	I_{FSM}	max.	500	mA

Temperatures

Storage temperature	T_{stg}	-65 to +200	$^{\circ}C$
Junction temperature	T_j	max. 200	$^{\circ}C$

THERMAL RESISTANCE

From junction to ambient in free air	$R_{th\ j-a}$	=	0,60	$^{\circ}C/mW$
--------------------------------------	---------------	---	------	----------------

CHARACTERISTICS

$T_j = 25\ ^{\circ}C$

Forward voltage

$I_F = 1\ mA$	V_F	<	0,7	V
$I_F = 10\ mA$	V_F	<	1,0	V
$I_F = 50\ mA$	V_F	<	1,5	V

Reverse current

$V_R = 10\ V$	I_R	<	50	nA
$V_R = 30\ V$	I_R	<	200	nA

Diode capacitance

$V_R = 0; f = 1\ MHz$	C_d	<	3	pF
-----------------------	-------	---	---	----

¹⁾ For sinusoidal operation $I_{F(AV)} = 48\ mA$.

CHARACTERISTICS (continued)

$T_j = 25\text{ }^\circ\text{C}$

Reverse recovery time when switched from

$I_F = 10\text{ mA}$ to $I_R = 60\text{ mA}$; $R_L = 100\text{ }\Omega$;
measured at $I_R = 1\text{ mA}$

$t_{rr} < 4\text{ ns}$

Test circuit and waveforms :

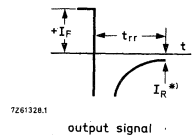
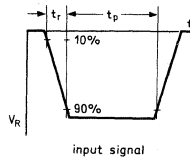
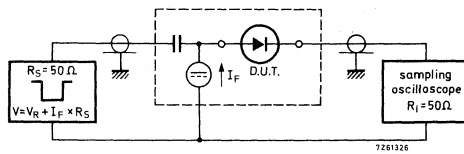

Input signal : Rise time of the reverse pulse

$t_r = 0,6\text{ ns}$

*) $I_R = 1\text{ mA}$

Reverse pulse duration

$t_p = 100\text{ ns}$

Duty factor

$\delta = 0,05$

Oscilloscope : Rise time

$t_r = 0,35\text{ ns}$

Circuit capacitance $C \leq 1\text{ pF}$ ($C = \text{oscilloscope input capacitance} + \text{parasitic capacitance}$)

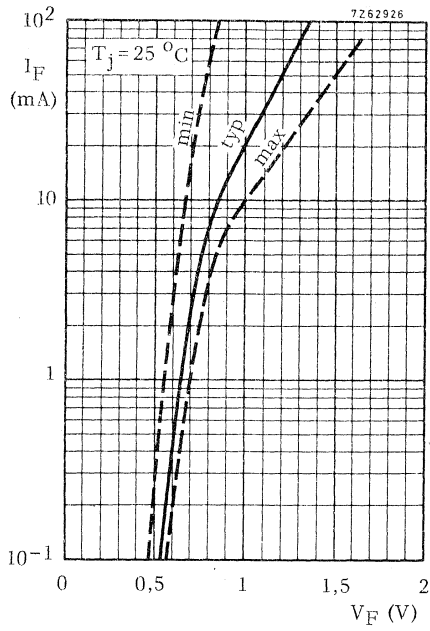

SILICON OXIDE PASSIVATED DIODE

Whiskerless diode in a hard glass subminiature envelope. The diode is intended for general purpose consumer applications.

QUICK REFERENCE DATA			
Continuous reverse voltage	V_R	max.	50 V
Repetitive peak forward current	I_{FRM}	max.	150 mA
Storage temperature	T_{stg}		-65 to +200 °C
Junction temperature	T_j	max.	200 °C
Thermal resistance from junction to ambient	$R_{th j-a}$	=	0,60 °C/mW
Forward voltage at $I_F = 1$ mA	V_F	<	0,7 V
$I_F = 10$ mA	V_F	<	1,0 V
$I_F = 50$ mA	V_F	<	1,5 V
Reverse recovery time when switched from $I_F = 10$ mA to $I_R = 60$ mA; $R_L = 100 \Omega$; measured at $I_R = 1$ mA	t_{rr}	<	4 ns

MECHANICAL DATA

Dimensions in mm

SOD-17

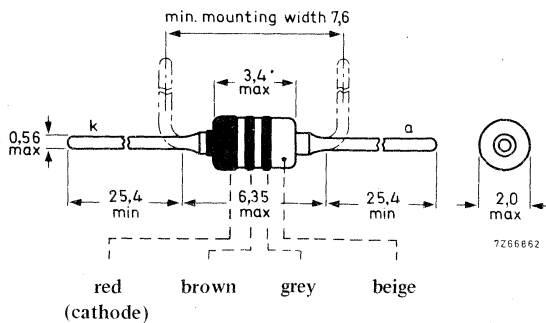

RATINGS Limiting values in accordance with the Absolute Maximum System (IEC 134)

Voltages

Continuous reverse voltage	V_R	max.	50	V
Repetitive peak reverse voltage	V_{RRM}	max.	50	V

Currents

Average rectified forward current (averaged over any 20 ms period)	$I_{F(AV)}$	max.	75	mA ¹⁾
Forward current (d. c.)	I_F	max.	75	mA
Repetitive peak forward current	I_{FRM}	max.	150	mA
Non-repetitive peak forward current t = 1 μ s	I_{FSM}	max.	2000	mA
t = 1 s	I_{FSM}	max.	500	mA

Temperatures

Storage temperature	T_{stg}	-65 to +200	$^{\circ}$ C
Junction temperature	T_j	max. 200	$^{\circ}$ C

THERMAL RESISTANCE

From junction to ambient in free air	$R_{th\ j-a}$	=	0,60	$^{\circ}$ C/mW
--------------------------------------	---------------	---	------	-----------------

CHARACTERISTICS

$T_j = 25\ ^{\circ}$ C

Forward voltage

$I_F = 1\ \text{mA}$	V_F	<	0,7	V
$I_F = 10\ \text{mA}$	V_F	<	1,0	V
$I_F = 50\ \text{mA}$	V_F	<	1,5	V

Reverse current

$V_R = 25\ \text{V}$	I_R	<	50	nA
$V_R = 50\ \text{V}$	I_R	<	200	nA

Diode capacitance

$V_R = 0; f = 1\ \text{MHz}$	C_d	<	3	pF
------------------------------	-------	---	---	----

¹⁾ For sinusoidal operation $I_{F(AV)} = 48\ \text{mA}$.

CHARACTERISTICS (continued)

$T_j = 25\text{ }^\circ\text{C}$

Reverse recovery time when switched from

$I_F = 10\text{ mA}$ to $I_R = 60\text{ mA}$; $R_L = 100\text{ }\Omega$;

measured at $I_R = 1\text{ mA}$

$t_{rr} < 4\text{ ns}$

Test circuit and waveforms :

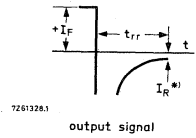
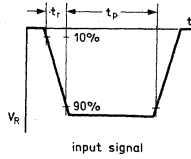
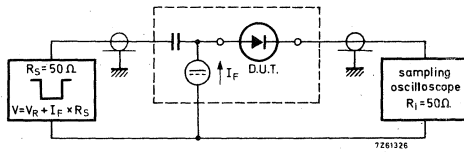

Input signal : Rise time of the reverse pulse

$t_r = 0,6\text{ ns}$

*) $I_R = 1\text{ mA}$

Reverse pulse duration

$t_p = 100\text{ ns}$

Duty factor

$\delta = 0,05$

Oscilloscope : Rise time

$t_r = 0,35\text{ ns}$

Circuit capacitance $C \leq 1\text{ pF}$ ($C =$ oscilloscope input capacitance + parasitic capacitance)

SILICON OXIDE PASSIVATED DIODE

Whiskerless diode in a hard glass subminiature envelope. The diode is intended for general purpose consumer applications.

QUICK REFERENCE DATA			
Continuous reverse voltage	V_R	max.	100 V
Repetitive peak forward current	I_{FRM}	max.	300 mA
Storage temperature	T_{stg}		-65 to +200 °C
Junction temperature	T_j	max.	200 °C
Thermal resistance from junction to ambient	$R_{th\ j-a}$	=	0,60 °C/mW
Forward voltage at $I_F =$	$I_F = 1\text{ mA}$	V_F	< 0,65 V
	$I_F = 10\text{ mA}$	V_F	< 0,85 V
	$I_F = 100\text{ mA}$	V_F	< 1,40 V
Reverse recovery time when switched from $I_F = 30\text{ mA}$ to $I_R = 30\text{ mA}$; $R_L = 100\ \Omega$; measured at $I_R = 3\text{ mA}$	t_{rr}	<	120 ns

MECHANICAL DATA

Dimensions in mm

SOD-17

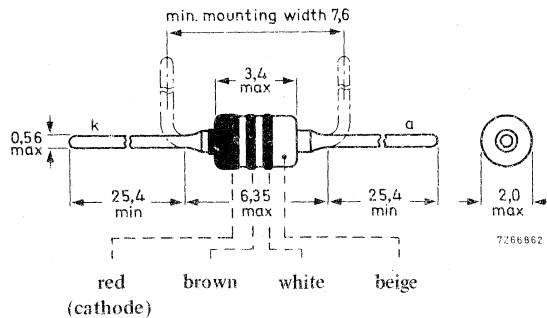

RATINGS Limiting values in accordance with the Absolute Maximum System (IEC 134)

Voltages

Continuous reverse voltage	V_R	max.	100	V
Repetitive peak reverse voltage	V_{RRM}	max.	100	V

Currents

Average rectified forward current (averaged over any 20 ms period)	$I_F(AV)$	max.	100	mA
Forward current (d. c.)	I_F	max.	100	mA
Repetitive peak forward current	I_{FRM}	max.	300	mA
Non-repetitive peak forward current $t = 1 \mu s$	I_{FSM}	max.	2000	mA
$t = 1 s$	I_{FSM}	max.	500	mA

Temperatures

Storage temperature	T_{stg}	-65 to +200	°C
Junction temperature	T_j	max. 200	°C

THERMAL RESISTANCE

From junction to ambient in free air	$R_{th j-a}$	=	0,60	°C/mW
--------------------------------------	--------------	---	------	-------

CHARACTERISTICS

$T_j = 25 \text{ °C}$

Forward voltage

$I_F = 1 \text{ mA}$	V_F	<	0,65	V
$I_F = 10 \text{ mA}$	V_F	<	0,85	V
$I_F = 100 \text{ mA}$	V_F	<	1,40	V

Reverse current

$V_R = 50 \text{ V}$	I_R	<	200	nA
$V_R = 100 \text{ V}$	I_R	<	500	nA

Diode capacitance

$V_R = 0; f = 1 \text{ MHz}$	C_d	<	5	pF
------------------------------	-------	---	---	----

CHARACTERISTICS (continued)

$T_j = 25\text{ }^\circ\text{C}$

Reverse recovery time when switched from

$I_F = 30\text{ mA}$ to $I_R = 30\text{ mA}$; $R_L = 100\text{ }\Omega$;

measured at $I_R = 3\text{ mA}$

$t_{rr} < 120\text{ ns}$

Test circuit and waveforms:

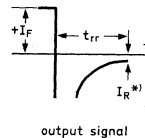
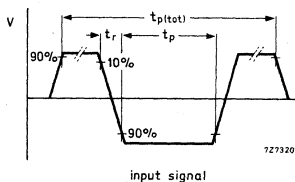
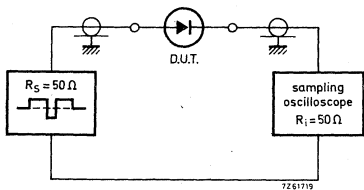

Input signal : Total pulse duration

$t_{p(tot)} = 10\text{ }\mu\text{s}$ *) $I_R = 3\text{ mA}$

Duty factor

$\delta = 0,0025$

Rise time of the reverse pulse

$t_r = 0,6\text{ ns}$

Reverse pulse duration

$t_p = 300\text{ ns}$

Oscilloscope : Rise time

$t_r = 0,35\text{ ns}$

Circuit capacitance $C \leq 1\text{ pF}$ ($C = \text{oscilloscope input capacitance} + \text{parasitic capacitance}$)

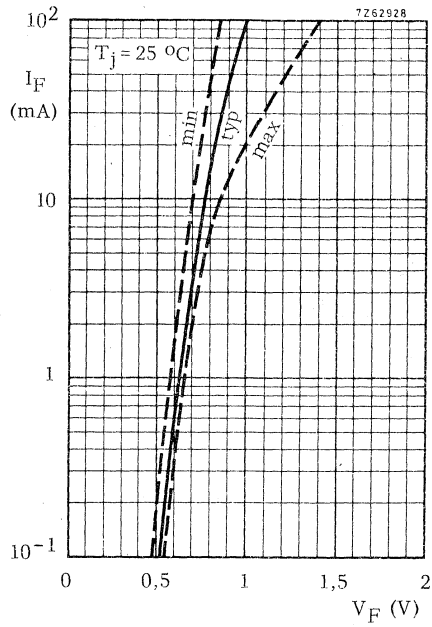

GENERAL PURPOSE DIODE

Silicon planar epitaxial diode in a DO-35 envelope; intended for general purpose and can also be used as regulator.

QUICK REFERENCE DATA			
Repetitive peak reverse voltage	V_{RRM}	max.	10 V
Repetitive peak forward current	I_{FRM}	max.	400 mA
Storage temperature	T_{stg}		-65 to +200 °C
Junction temperature	T_j	max.	200 °C
Thermal resistance from junction to ambient	$R_{th j-a}$	=	0,50 °C/mW
Forward voltage at $I_F = 0,1$ mA	V_F		460 to 520 mV
$I_F = 1,0$ mA	V_F		560 to 620 mV
$I_F = 10$ mA	V_F		680 to 750 mV
$I_F = 100$ mA	V_F		825 to 950 mV
Diode capacitance at $V_R = 0$; $f = 1$ MHz	C_d	<	2,5 pF
Reverse recovery time when switched from $I_F = 10$ mA to $I_R = 60$ mA; $R_L = 100 \Omega$; measured at $I_R = 1$ mA	t_{rr}	<	4 ns

MECHANICAL DATA

Dimensions in mm

DO-35

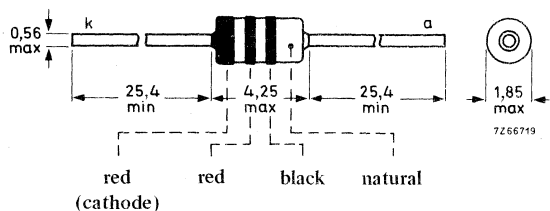

RATINGS Limiting values in accordance with the Absolute Maximum System (IEC 134)

Voltage

Repetitive peak reverse voltage V_{RRM} max. 10 V

Currents

Average rectified forward current
(averaged over any 20 ms period) $I_{F(AV)}$ max. 200 mA ¹⁾

Forward current (d. c.) I_F max. 200 mA

Repetitive peak forward current I_{FRM} max. 400 mA

Non-repetitive peak forward current
 $t = 1 \mu s$ I_{FSM} max. 4000 mA

$t = 1 s$ I_{FSM} max. 1000 mA

Temperatures

Storage temperature T_{stg} -65 to +200 °C

Junction temperature T_j max. 200 °C

THERMAL RESISTANCE

From junction to ambient in free air $R_{th j-a} = 0,50$ °C/mW

CHARACTERISTICS

$T_j = 25$ °C

Forward voltage

$I_F = 0,1$ mA V_F 460 to 520 mV

$I_F = 1,0$ mA V_F 560 to 620 mV

$I_F = 5,0$ mA V_F 640 to 700 mV

$I_F = 10$ mA V_F 680 to 750 mV

$I_F = 100$ mA V_F 825 to 950 mV

Reverse current

$V_R = 10$ V $I_R < 1500$ nA

Diode capacitance

$V_R = 0$; $f = 1$ MHz $C_d < 2,5$ pF

¹⁾ For sinusoidal operation $I_{F(AV)} = 130$ mA.

CHARACTERISTICS (continued)

$T_j = 25\text{ }^\circ\text{C}$

Reverse recovery time when switched from

$$I_F = 10\text{ mA to } I_R = 60\text{ mA; } R_L = 100\text{ }\Omega;$$

measured at $I_R = 1\text{ mA}$

$$t_{rr} < 4\text{ ns}$$

Test circuit and waveforms :

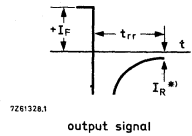
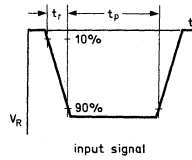
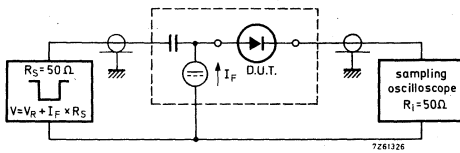

Input signal : Rise time of the reverse pulse

$$t_r = 0,6\text{ ns}$$

*) $I_R = 1\text{ mA}$

Reverse pulse duration

$$t_p = 100\text{ ns}$$

Duty factor

$$\delta = 0,05$$

Oscilloscope : Rise time

$$t_r = 0,35\text{ ns}$$

Circuit capacitance $C \leq 1\text{ pF}$ ($C =$ oscilloscope input capacitance + parasitic capacitance)

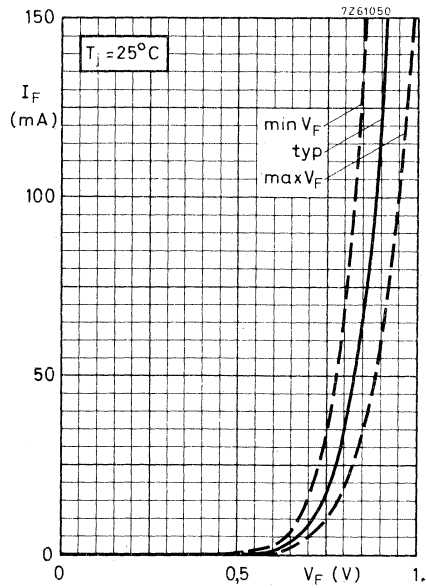

GENERAL PURPOSE DIODE

Silicon planar epitaxial diode in a DO-35 envelope; intended for general purposes.

QUICK REFERENCE DATA			
Continuous reverse voltage	V_R	max.	30 V
Repetitive peak forward current	I_{FRM}	max.	400 mA
Storage temperature	T_{stg}		-65 to +200 °C
Junction temperature	T_j	max.	200 °C
Thermal resistance from junction to ambient	$R_{th j-a}$	=	0,50 °C/mW
Forward voltage at $I_F = 1$ mA	V_F	<	625 mV
$I_F = 100$ mA	V_F	<	950 mV
$I_F = 200$ mA	V_F	<	1050 mV
Diode capacitance at $V_R = 0$; $f = 1$ MHz	C_d	<	2,5 pF
Reverse recovery time when switched from $I_F = 10$ mA to $I_R = 60$ mA; $R_L = 100 \Omega$; measured at $I_R = 1$ mA	t_{rr}	<	4 ns

MECHANICAL DATA

Dimensions in mm

DO-35

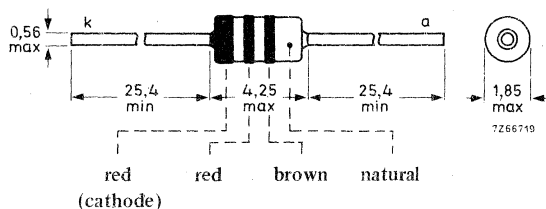

RATINGS Limiting values in accordance with the Absolute Maximum System (IEC 134)

Voltages

Continuous reverse voltage	V_R	max.	30	V
Repetitive peak reverse voltage	V_{RRM}	max.	30	V

Currents

Average rectified forward current (averaged over any 20 ms period)	$I_{F(AV)}$	max.	200	mA ¹⁾
Forward current (d. c.)	I_F	max.	200	mA
Repetitive peak forward current	I_{FRM}	max.	400	mA
Non-repetitive peak forward current				
$t = 1 \mu s$	I_{FSM}	max.	4000	mA
$t = 1 s$	I_{FSM}	max.	1000	mA

Temperatures

Storage temperature	T_{stg}	-65 to +200	°C
Junction temperature	T_j	max. 200	°C

THERMAL RESISTANCE

From junction to ambient in free air	$R_{th j-a}$	=	0,50	°C/mW
--------------------------------------	--------------	---	------	-------

CHARACTERISTICS

$T_j = 25 \text{ }^\circ\text{C}$

Forward voltage

$I_F = 1 \text{ mA}$	V_F	<	625	mV
$I_F = 100 \text{ mA}$	V_F	<	950	mV
$I_F = 200 \text{ mA}$	V_F	<	1050	mV

Reverse current

$V_R = 10 \text{ V}$	I_R	<	25	nA
$V_R = 30 \text{ V}$	I_R	<	200	nA

Diode capacitance

$V_R = 0; f = 1 \text{ MHz}$	C_d	<	2,5	pF
------------------------------	-------	---	-----	----

1) For sinusoidal operation $I_{F(AV)} = 130 \text{ mA}$.

CHARACTERISTICS (continued)

$T_j = 25\text{ }^\circ\text{C}$

Reverse recovery time when switched from

$I_F = 10\text{ mA}$ to $I_R = 60\text{ mA}$; $R_L = 100\text{ }\Omega$;

measured at $I_R = 1\text{ mA}$

$t_{rr} < 4\text{ ns}$

Test circuit and waveforms :

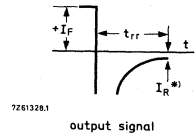
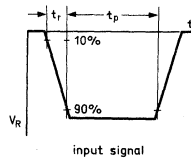
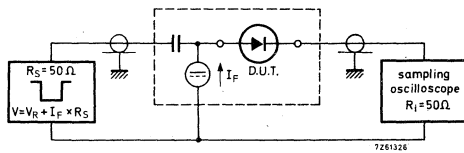

Input signal : Rise time of the reverse pulse

$t_r = 0,6\text{ ns}$

*) $I_R = 1\text{ mA}$

Reverse pulse duration

$t_p = 100\text{ ns}$

Duty factor

$\delta = 0,05$

Oscilloscope : Rise time

$t_r = 0,35\text{ ns}$

Circuit capacitance $C \leq 1\text{ pF}$ ($C =$ oscilloscope input capacitance + parasitic capacitance)

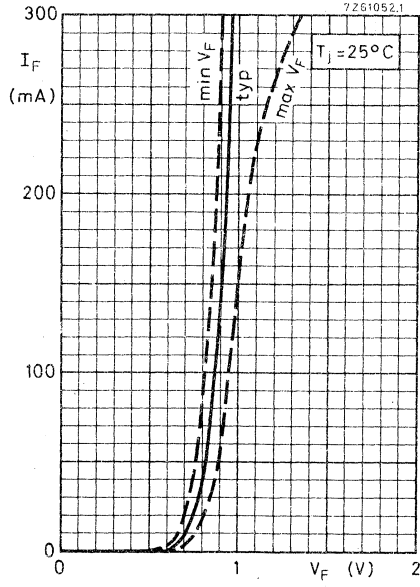

BA221

GENERAL PURPOSE DIODE

Silicon planar epitaxial diode in a DO-35 envelope; intended for general purposes.

QUICK REFERENCE DATA			
Continuous reverse voltage	V_R	max.	50 V
Repetitive peak forward current	I_{FRM}	max.	150 mA
Storage temperature	T_{stg}	-65 to +200	°C
Junction temperature	T_j	max.	200 °C
Thermal resistance from junction to ambient	$R_{th j-a}$	=	0,60 °C/mW
Forward voltage at $I_F = 1$ mA	V_F	<	700 mV
$I_F = 10$ mA	V_F	<	900 mV
$I_F = 50$ mA	V_F	<	1100 mV
Diode capacitance at $V_R = 0$; $f = 1$ MHz	C_d	<	2,0 pF
Reverse recovery time when switched from $I_F = 10$ mA to $I_R = 60$ mA; $R_L = 100 \Omega$; measured at $I_R = 1$ mA	t_{rr}	<	4 ns

MECHANICAL DATA

Dimensions in mm

DO-35

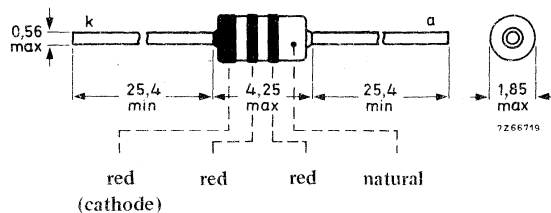

RATINGS Limiting values in accordance with the Absolute Maximum System (IEC 134)

Voltages

Continuous reverse voltage	V_R	max.	50	V
Repetitive peak reverse voltage	V_{RRM}	max.	50	V

Currents

Average rectified forward current (averaged over any 20 ms period)	$I_{F(AV)}$	max.	75	mA ¹⁾
Forward current (d. c.)	I_F	max.	75	mA
Repetitive peak forward current	I_{FRM}	max.	150	mA
Non-repetitive peak forward current t = 1 μ s	I_{FSM}	max.	2000	mA
t = 1 s	I_{FSM}	max.	500	mA

Temperatures

Storage temperature	T_{stg}	-65 to +200	$^{\circ}C$
Junction temperature	T_j	max. 200	$^{\circ}C$

THERMAL RESISTANCE

From junction to ambient in free air	$R_{th\ j-a}$	=	0,60	$^{\circ}C/mW$
--------------------------------------	---------------	---	------	----------------

CHARACTERISTICS

$T_j = 25\ ^{\circ}C$

Forward voltage

$I_F = 1\ mA$	V_F	<	700	mV
$I_F = 10\ mA$	V_F	<	900	mV
$I_F = 50\ mA$	V_F	<	1100	mV

Reverse current

$V_R = 25\ V$	I_R	<	50	nA
$V_R = 50\ V$	I_R	<	200	nA

Diode capacitance

$V_R = 0; f = 1\ MHz$	C_d	<	2	pF
-----------------------	-------	---	---	----

1) For sinusoidal operation $I_{F(AV)} = 48\ mA$.

CHARACTERISTICS (continued)

$T_j = 25\text{ }^\circ\text{C}$

Reverse recovery time when switched from

$I_F = 10\text{ mA}$ to $I_R = 60\text{ mA}$; $R_L = 100\text{ }\Omega$;

measured at $I_R = 1\text{ mA}$

$t_{rr} < 4\text{ ns}$

Test circuit and waveforms :

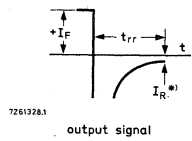
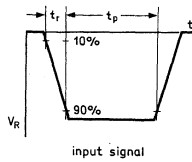
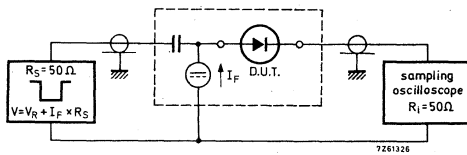

Input signal : Rise time of the reverse pulse

$t_r = 0,6\text{ ns}$

*) $I_R = 1\text{ mA}$

Reverse pulse duration

$t_p = 100\text{ ns}$

Duty factor

$\delta = 0,05$

Oscilloscope : Rise time

$t_r = 0,35\text{ ns}$

Circuit capacitance $C \leq 1\text{ pF}$ ($C =$ oscilloscope input capacitance + parasitic capacitance)

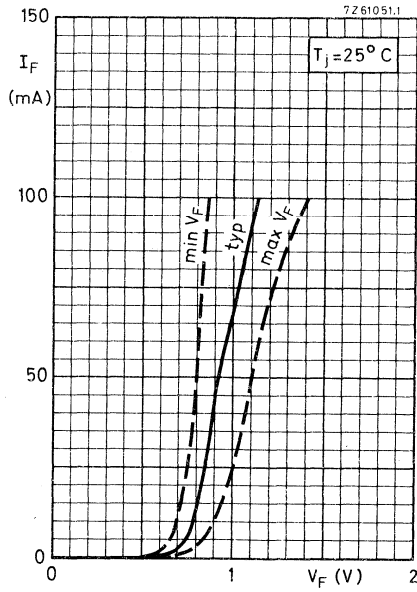

10 V, 30 V and 50 V GENERAL PURPOSE DIODES

Silicon planar epitaxial diodes in DO-35 envelopes intended for general purpose applications.

They have reverse voltages up to 10 V for BA316, 30 V for BA317 and 50 V for BA318.

QUICK REFERENCE DATA						
		BA316 BA317 BA318				
Continuous reverse voltage	V_R	max.	10	30	50	V
Repetitive peak forward current	I_{FRM}	max.	225			mA
Storage temperature	T_{stg}		-65 to +200			°C
Junction temperature	T_j	max.	200			°C
Thermal resistance from junction to ambient	$R_{th j-a}$	=	0,60			°C/mW
Forward voltage at $I_F = 1,0$ mA	V_F	<	700			mV
	V_F	<	850			mV
	V_F	<	1100			mV
Diode capacitance at $V_R = 0$; $f = 1$ MHz	C_d	<	3			pF
Reverse recovery time when switched from $I_F = 10$ mA to $I_R = 60$ mA; $R_L = 100 \Omega$; measured at $I_R = 1$ mA	t_{rr}	<	4			ns

MECHANICAL DATA

Dimensions in mm

DO-35

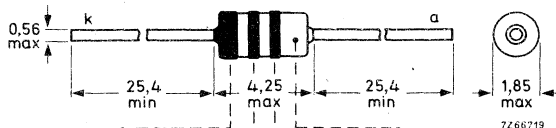

BA316:	orange	brown	blue	natural
BA317:	orange	brown	violet	natural
BA318:	orange	brown	grey	natural

(cathode)

RATINGS Limiting values in accordance with the Absolute Maximum System (IEC134)

<u>Voltage</u>		BA316	BA317	BA318
Continuous reverse voltage	V_R max.	10	30	50 V

Currents

Average rectified forward current → (averaged over any 20 ms period)	$I_{F(AV)}$ max.	100	mA	1)
Forward current (d. c.)	I_F max.	100	mA	
Repetitive peak forward current	I_{FRM} max.	225	mA	
Non-repetitive peak forward current $t = 1 \mu s$	I_{FSM} max.	2000	mA	
$t = 1 s$	I_{FSM} max.	500	mA	

Temperatures

Storage temperature	T_{stg}	-65 to +200	$^{\circ}C$
Junction temperature	T_j max.	200	$^{\circ}C$

THERMAL RESISTANCE

From junction to ambient in free air	$R_{th j-a} =$	0,60	$^{\circ}C/mW$
--------------------------------------	----------------	------	----------------

CHARACTERISTICS

$T_j = 25^{\circ}C$

Forward voltage

$I_F = 1,0 \text{ mA}$	$V_F <$	700	mV
$I_F = 10 \text{ mA}$	$V_F <$	850	mV
$I_F = 100 \text{ mA}$	$V_F <$	1100	mV

Reverse current

		BA316	BA317	BA318
$V_R = 10 \text{ V}$	$I_R <$	200	50	- nA
$V_R = 30 \text{ V}$	$I_R <$	-	200	50 nA
$V_R = 50 \text{ V}$	$I_R <$	-	-	200 nA

Diode capacitance

$V_R = 0; f = 1 \text{ MHz}$	$C_d <$	3	pF
------------------------------	---------	---	----

→ 1) For sinusoidal operation see page 6. For pulse operation see pages 4 and 5.

CHARACTERISTICS (continued)

$T_j = 25\text{ }^\circ\text{C}$

Reverse recovery time when switched from

$I_F = 10\text{ mA}$ to $I_R = 60\text{ mA}$; $R_L = 100\text{ }\Omega$;

Measured at $I_R = 1\text{ mA}$

$t_{rr} < 4\text{ ns}$

Test circuit and waveforms:

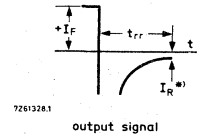
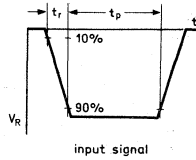
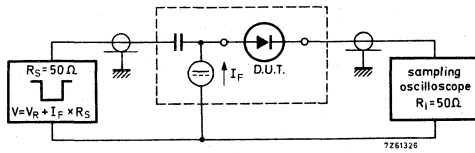

Input signal : Rise time of the reverse pulse

$t_r = 0,6\text{ ns}$

$I_R = 1\text{ mA}$

Reverse pulse duration

$t_p = 100\text{ ns}$

Duty factor

$\delta = 0,05$

Oscilloscope: Rise time

$t_r = 0,35\text{ ns}$

Circuit capacitance $C \leq 1\text{ pF}$ ($C =$ oscilloscope input capacitance + parasitic capacitance)

BA316
BA317
BA318

7272405

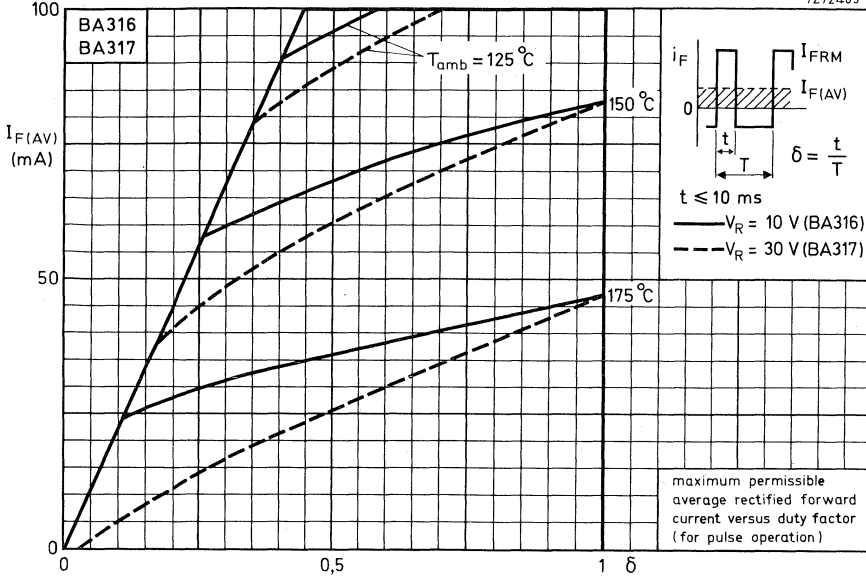

7272406

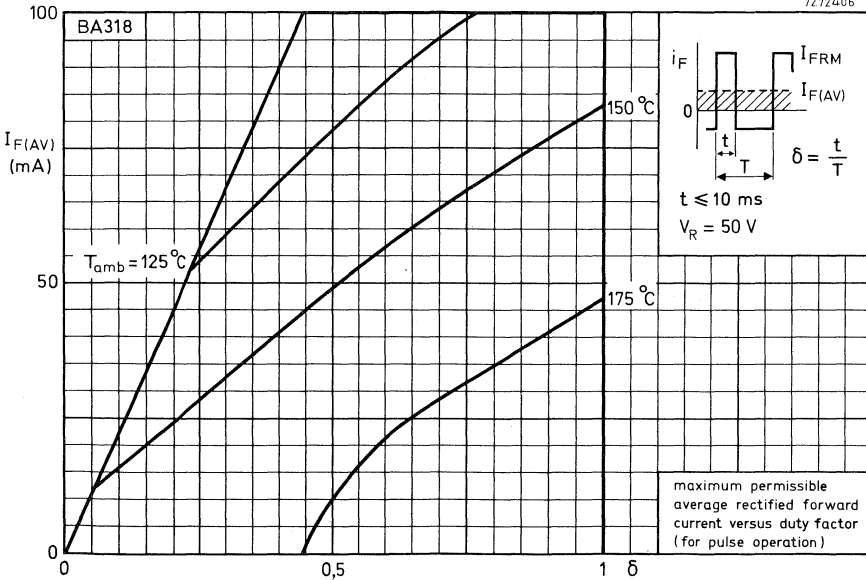

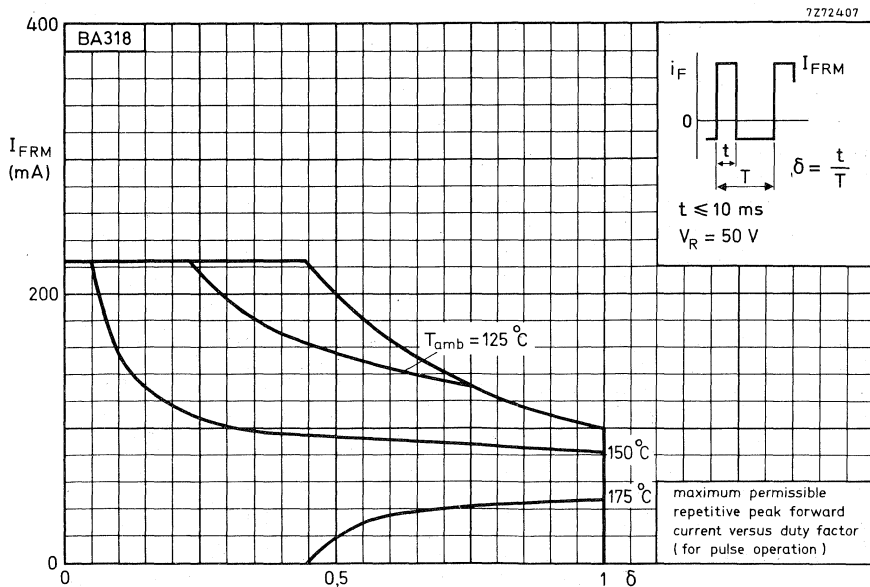
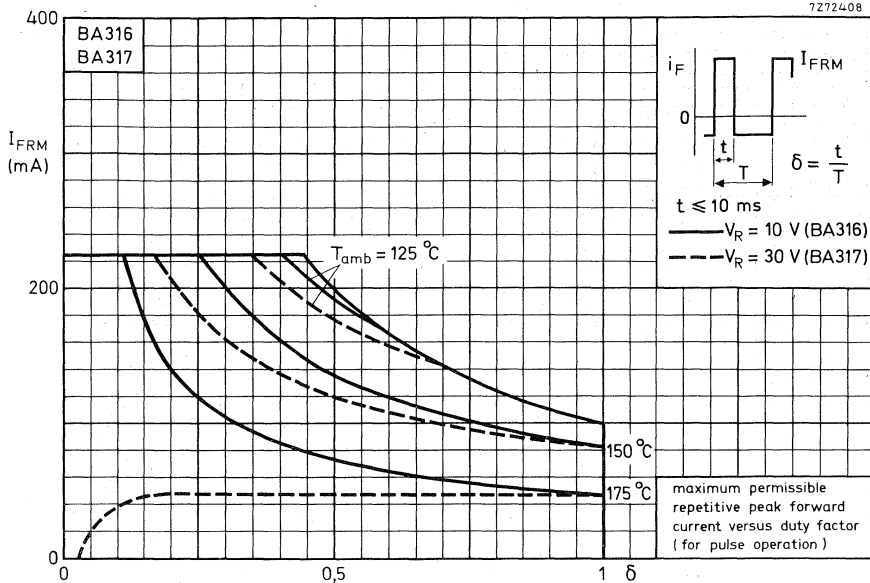

**BA316
BA317
BA318**

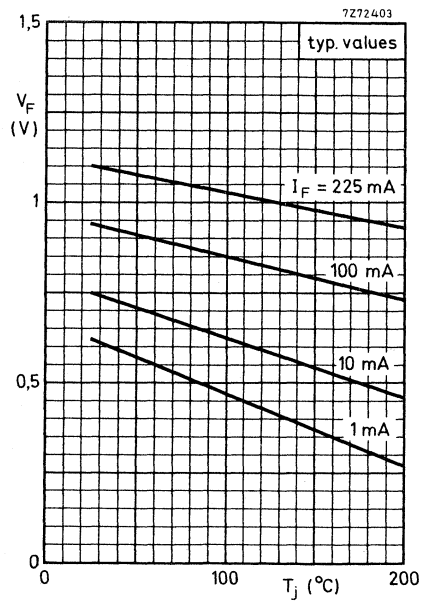
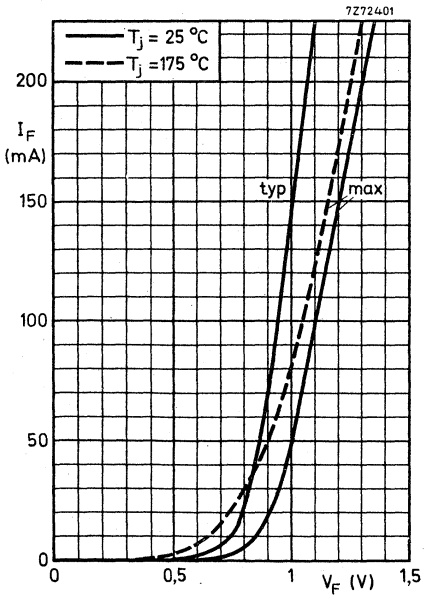
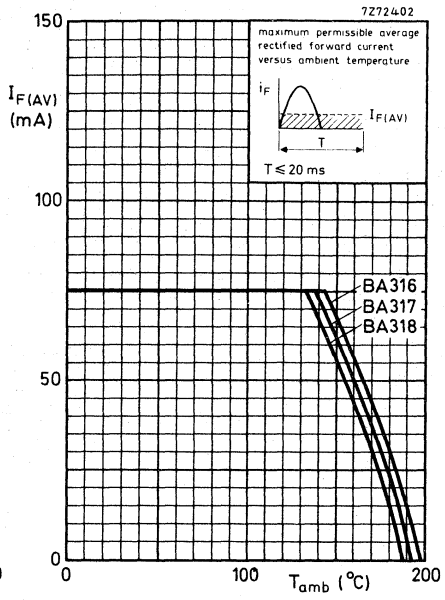
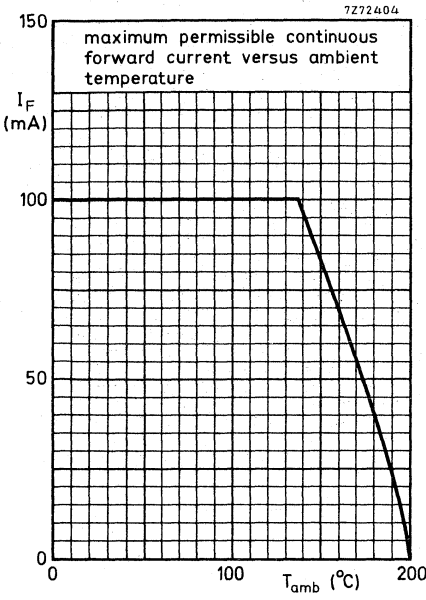

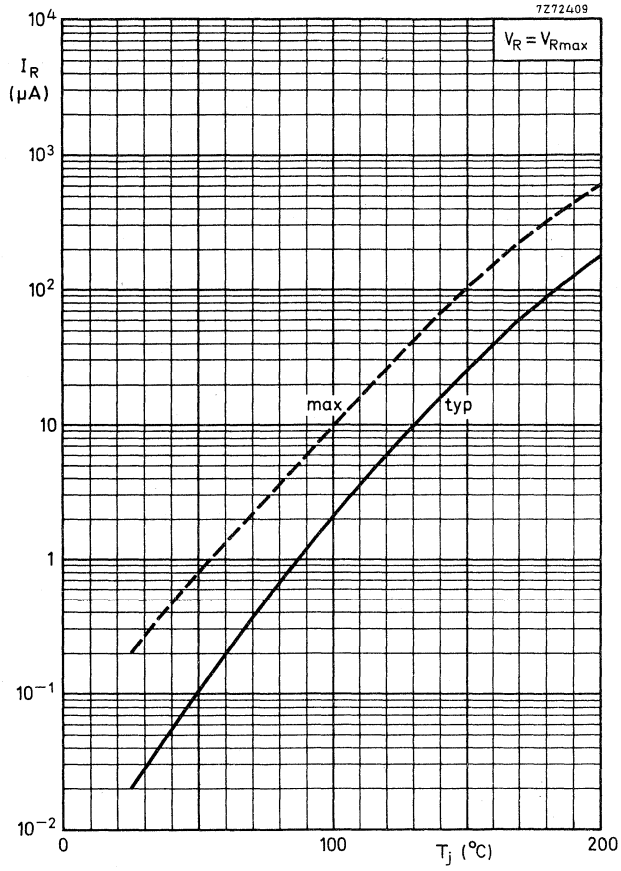

ULTRA-HIGH-SPEED DIODE

Silicon planar epitaxial, ultra-high-speed, high-conductance diode in a DO-35 envelope. The BAV10 is primarily intended for core gating in very fast memories.

QUICK REFERENCE DATA			
Continuous reverse voltage	V_R	max.	60 V
Repetitive peak reverse voltage	V_{RRM}	max.	60 V
Repetitive peak forward current	I_{FRM}	max.	600 mA
Junction temperature	T_j	max.	200 °C
Forward voltage at $I_F = 200$ mA	V_F	<	1,0 V
Reverse recovery time when switched from $I_F = 400$ mA to $I_R = 400$ mA; $R_L = 100 \Omega$; measured at $I_R = 40$ mA	t_{rr}	<	6 ns
Recovery charge when switched from $I_F = 10$ mA to $V_R = 5$ V; $R_L = 500 \Omega$	Q_s	<	50 pC

MECHANICAL DATA

Dimensions in mm

DO-35

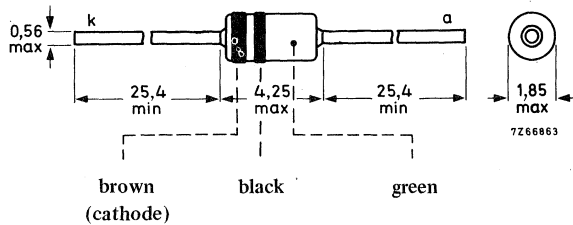

RATINGS Limiting values in accordance with the Absolute Maximum System (IEC 134)

Voltages

Continuous reverse voltage	V_R	max.	60 V
Repetitive peak reverse voltage	V_{RRM}	max.	60 V ¹⁾

Currents

Average rectified forward current	$I_{F(AV)}$	max.	300 mA ²⁾
Forward current (d. c.)	I_F	max.	300 mA
Repetitive peak forward current	I_{FRM}	max.	600 mA
Non-repetitive peak forward current $t = 1 \mu s$	I_{FSM}	max.	4000 mA
$t = 1 s$	I_{FSM}	max.	1000 mA

Temperatures

Storage temperature	T_{stg}	-65 to +200 °C
Junction temperature	T_j	max. 200 °C

THERMAL RESISTANCE

From junction to ambient in free air at maximum lead length	$R_{th j-a}$	=	0,5 °C/mW
--	--------------	---	-----------

CHARACTERISTICS

$T_j = 25 \text{ }^\circ\text{C}$ unless otherwise specified

Forward voltage

$I_F = 10 \text{ mA}$	V_F	<	0,75 V
$I_F = 200 \text{ mA}$	V_F	<	1,00 V
$I_F = 200 \text{ mA}; T_j = 100 \text{ }^\circ\text{C}$	V_F	<	0,95 V
$I_F = 500 \text{ mA}$	V_F	<	1,25 V

Reverse current

$V_R = 60 \text{ V}$	I_R	<	100 nA
$V_R = 60 \text{ V}; T_j = 150 \text{ }^\circ\text{C}$	I_R	<	100 μA

Diode capacitance

$V_R = 0; f = 1 \text{ MHz}$	C_d	<	2,5 pF
------------------------------	-------	---	--------

1) Measured at zero life time at $I_R = 10 \mu\text{A}; V_R = 75 \text{ V}$.

2) For sinusoidal operation see page 6. For pulse operation see page 5.

CHARACTERISTICS (continued)

$T_j = 25\text{ }^\circ\text{C}$

Forward recovery voltage when switched to

$I_F = 400\text{ mA}; t_{r1} = 30\text{ ns}$

$V_{fr} < 2,0\text{ V}$

$I_F = 400\text{ mA}; t_{r2} = 100\text{ ns}$

$V_{fr} < 1,5\text{ V}$

Test circuit and waveforms:

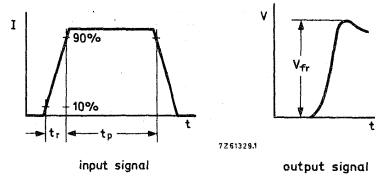
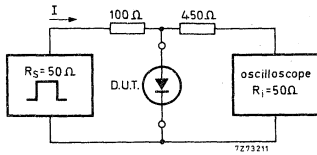

Input signal : 1st rise time of the forward pulse $t_{r1} = 30\text{ ns}$

2nd rise time of the forward pulse $t_{r2} = 100\text{ ns}$

Forward current pulse duration $t_p = 300\text{ ns}$

Duty factor $\delta = 0,01$

Oscilloscope: Rise time $t_r = 0,35\text{ ns}$

Input capacitance $C_i \leq 1\text{ pF}$

Circuit capacitance $C \leq 20\text{ pF}$ ($C = C_i + \text{parasitic capacitance}$)

Reverse recovery time when switched from

$I_F = 400\text{ mA}$ to $I_R = 400\text{ mA}; R_L = 100\text{ }\Omega$;
measured at $I_R = 40\text{ mA}$

$t_{rr} < 6\text{ ns}$

Test circuit and waveforms:

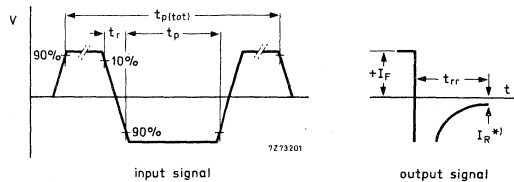
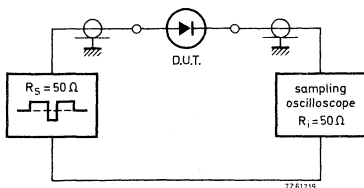

Input signal : Total pulse duration

$t_{p(\text{tot})} = 0,2\text{ }\mu\text{s}$

*) $I_R = 40\text{ mA}$

Duty factor $\delta = 0,0025$

Rise time of the reverse pulse $t_r = 0,6\text{ ns}$

Reverse pulse duration $t_p = 30\text{ ns}$

Oscilloscope: Rise time $t_r = 0,35\text{ ns}$

Circuit capacitance $C \leq 1\text{ pF}$ ($C = \text{oscilloscope input capacitance} + \text{parasitic capacitance}$)

CHARACTERISTICS (continued)

$T_j = 25\text{ }^\circ\text{C}$

Recovery charge when switched from

$I_F = 10\text{ mA}$ to $V_R = 5\text{ V}$; $R_L = 500\ \Omega$

$Q_S < 50\text{ pC}$

Test circuit and waveform:

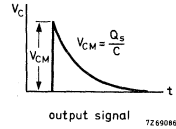
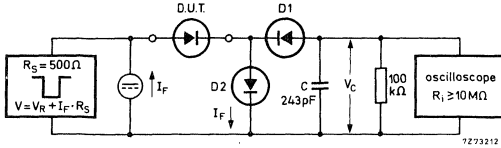

D1 = BAW62

D2 = diode with minority carrier life time at 10 mA: $< 200\text{ ps}$

Input signal : Rise time of the reverse pulse $t_r = 2\text{ ns}$

Reverse pulse duration $t_p = 400\text{ ns}$

Duty factor $\delta = 0,02$

Circuit capacitance $C \leq 7\text{ pF}$ ($C =$ oscilloscope input capacitance + parasitic capacitance)

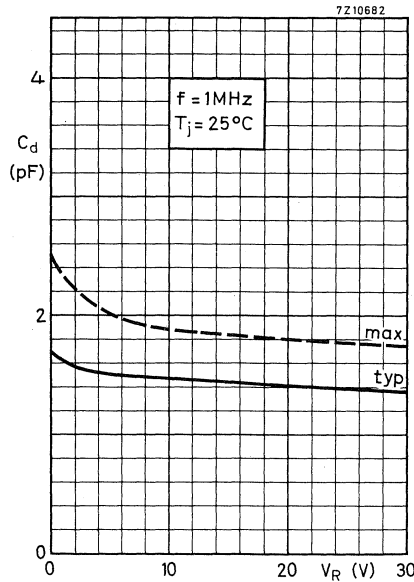

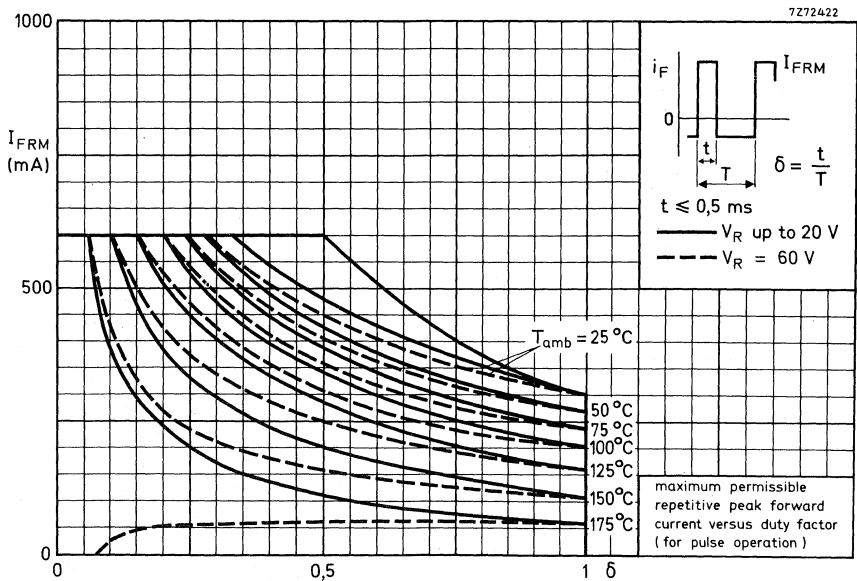
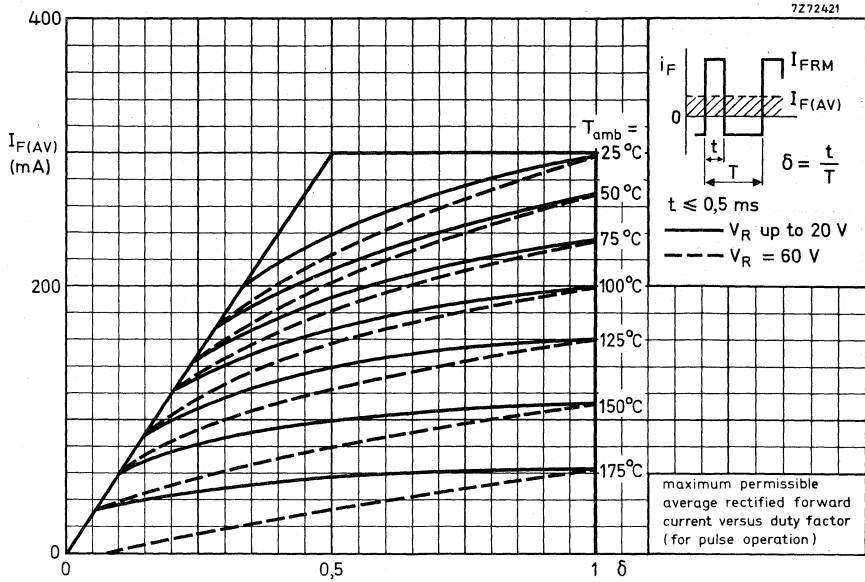

7210678.1

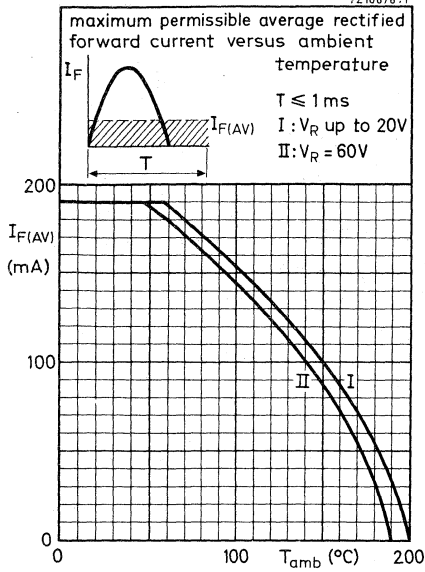

7210677.1

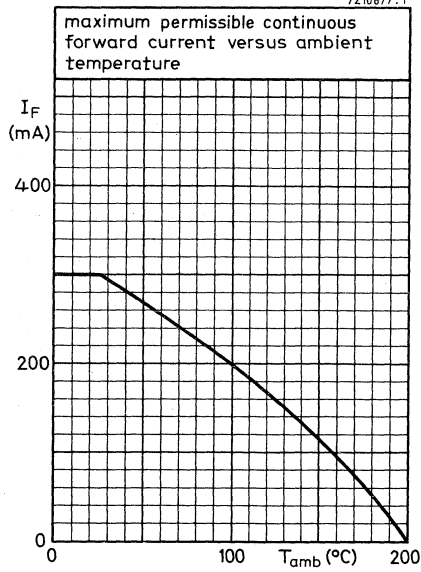

7210683.1

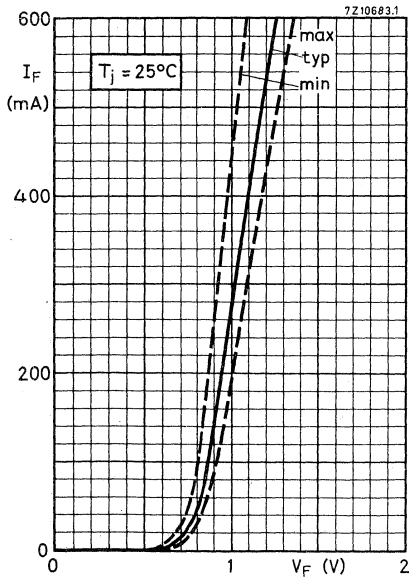

7210684

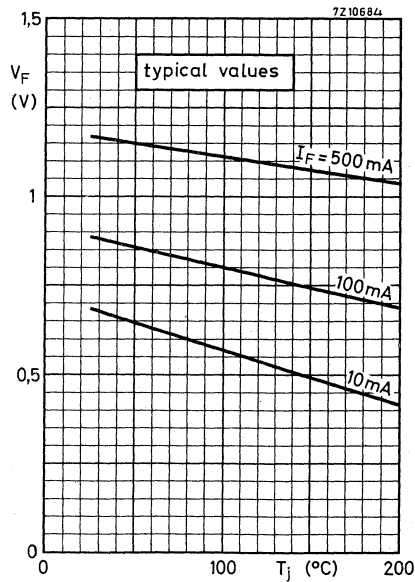

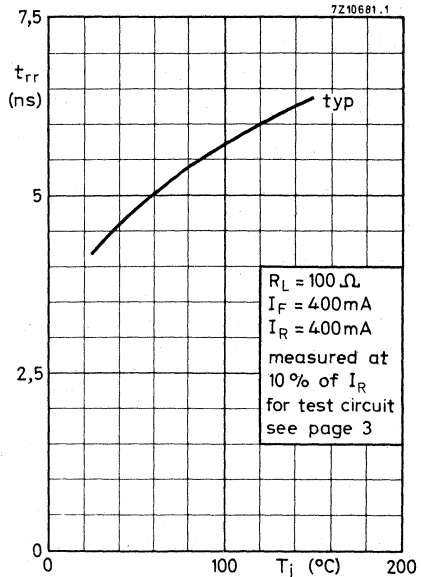
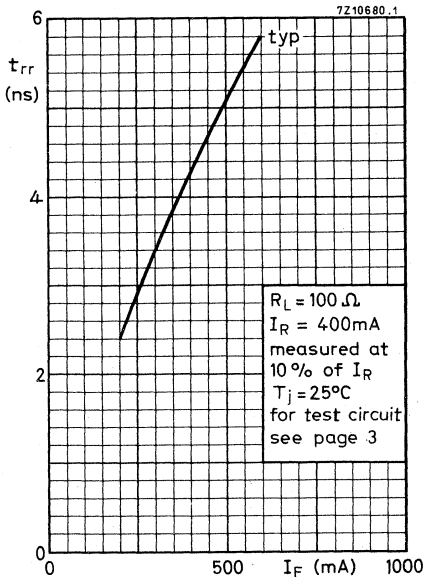
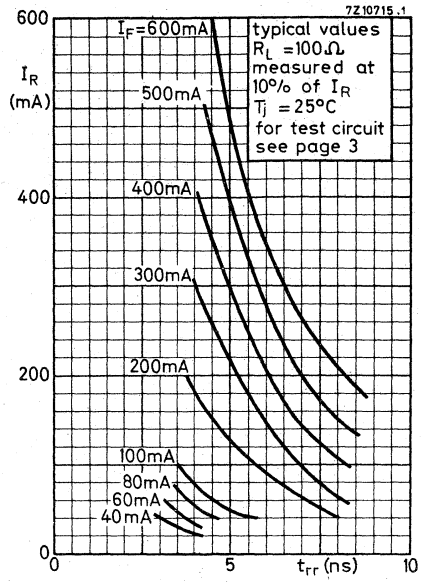
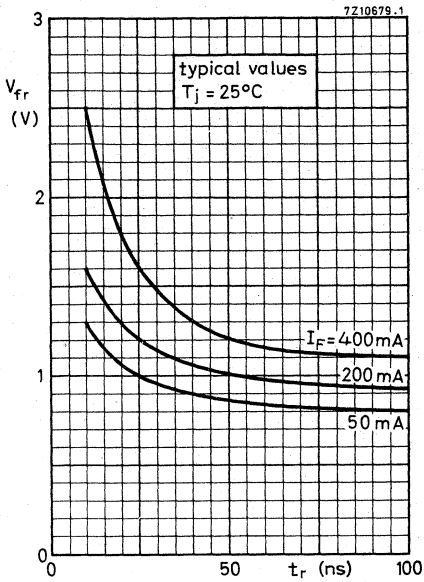

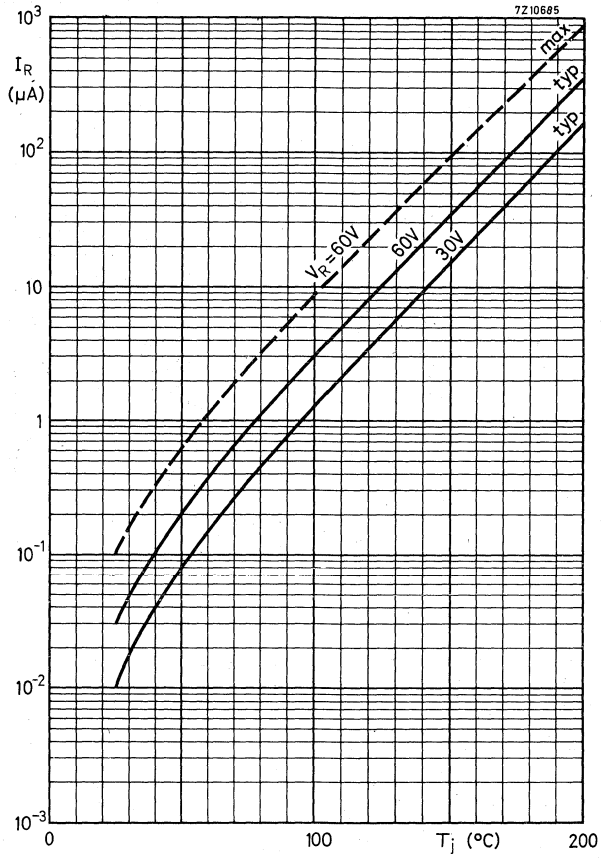

GENERAL PURPOSE DIODES

Silicon planar epitaxial diodes in DO-35 envelopes; intended for switching and general purposes in industrial equipment e.g. oscilloscopes, digital voltmeters and video output stages in colour television.

QUICK REFERENCE DATA						
			BAV18	BAV19	BAV20	BAV21
Continuous reverse voltage	V_R	max.	50	100	150	200 V
Forward current (d.c.)	I_F	max.	250	250	250	250 mA
Junction temperature	T_j	max.	175	175	175	175 °C
Thermal resistance from junction to ambient	$R_{th\ j-a}$	=	0,375	0,375	0,375	0,375 °C/mW
Forward voltage at $I_F = 100\text{ mA}$	V_F	<	1,0	1,0	1,0	1,0 V
Reverse current at $V_R = 50\text{ V}$	I_R	<	100	-	-	- nA
$V_R = 100\text{ V}$	I_R	<	-	100	-	- nA
$V_R = 150\text{ V}$	I_R	<	-	-	100	- nA
$V_R = 200\text{ V}$	I_R	<	-	-	-	100 nA
Diode capacitance at $V_R = 0; f = 1\text{ MHz}$	C_d	typ.	1,5	1,5	1,5	1,5 pF
		<	5,0	5,0	5,0	5,0 pF
Reverse recovery time when switched from $I_F = 30\text{ mA}$ to $I_R = 30\text{ mA}; R_L = 100\ \Omega$; measured at $I_R = 3\text{ mA}$	t_{rr}	<	50	50	50	50 ns

MECHANICAL DATA

Dimensions in mm

DO-35

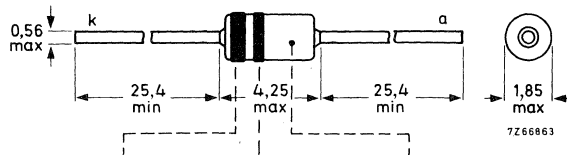

BAV18:	brown	grey	green
BAV19:	brown	white	green
BAV20:	red	black	green
BAV21:	red	brown	green

(cathode)

RATINGS Limiting values in accordance with the Absolute Maximum System (IEC134)

Voltages

			BAV18	BAV19	BAV20	BAV21	
Continuous reverse voltage	V_R	max.	50	100	150	200	V
Repetitive peak reverse voltage	V_{RRM}	max.	60	120	200	250	V

Currents

→ Average rectified forward current	$I_{F(AV)}$	max.	250	mA	¹⁾
Forward current (d. c.)	I_F	max.	250	mA	
Repetitive peak forward current	I_{FRM}	max.	625	mA	
Non-repetitive peak forward current $t < 1$ s; $T_j = 25$ °C	I_{FSM}	max.	1	A	

Power dissipation

Total power dissipation up to $T_{amb} = 25$ °C	P_{tot}	max.	400	mW
---	-----------	------	-----	----

Temperatures

Storage temperature	T_{stg}	-65 to +175	°C
Junction temperature	T_j	max. 175	°C

THERMAL RESISTANCE

From junction to ambient in free air	$R_{th j-a}$	=	0,375	°C/mW
--------------------------------------	--------------	---	-------	-------

→ ¹⁾ For sinusoidal operation see page 6. For pulse operation see pages 4 and 5.

CHARACTERISTICS

$T_j = 25\text{ }^\circ\text{C}$ unless otherwise specified

Forward voltage

$I_F = 100\text{ mA}$	V_F	$<$	$1,0$	V
$I_F = 200\text{ mA}$	V_F	$<$	$1,25$	V

Reverse avalanche breakdown voltage

$I_R = 100\text{ }\mu\text{A}$	$V_{(BR)R}$	$>$	BAV18 60	BAV19 120	BAV20 200	BAV21 250	V	¹⁾
--------------------------------	-------------	-----	---------------	----------------	----------------	----------------	-----	---------------

Reverse current

$V_R = V_{Rmax}$	I_R	$<$	100	nA
$V_R = V_{Rmax}; T_j = 150\text{ }^\circ\text{C}$	I_R	$<$	100	μA

Differential resistance

$I_F = 10\text{ mA}$	r_{diff}	$typ.$	5	Ω
----------------------	------------	--------	-----	----------

Diode capacitance

$V_R = 0; f = 1\text{ MHz}$	C_d	$typ.$	$1,5$	pF
		$<$	$5,0$	pF

Reverse recovery time when switched from

$I_F = 30\text{ mA}$ to $I_R = 30\text{ mA}; R_L = 100\text{ }\Omega$; measured at $I_R = 3\text{ mA}$	t_{RR}	$<$	50	ns
--	----------	-----	------	------

Test circuit and waveforms:

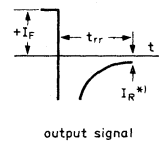
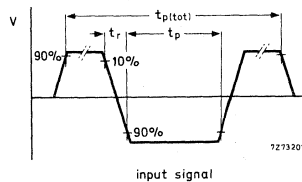
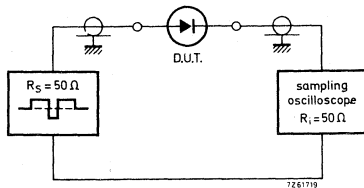

Input signal : Total pulse duration

$$t_{p(tot)} = 2\text{ }\mu\text{s} \quad \text{*) } I_R = 3\text{ mA}$$

Duty factor

$$\delta = 0,0025$$

Rise time of the reverse pulse

$$t_r = 0,6\text{ ns}$$

Reverse pulse duration

$$t_p = 100\text{ ns}$$

Oscilloscope: Rise time

$$t_r = 0,35\text{ ns}$$

Circuit capacitance $C \leq 1\text{ pF}$ ($C = \text{oscilloscope input capacitance} + \text{parasitic capacitance}$)

¹⁾ At zero life time, measured under pulse conditions to avoid excessive dissipation and voltage limited at 275 V.

7Z72413

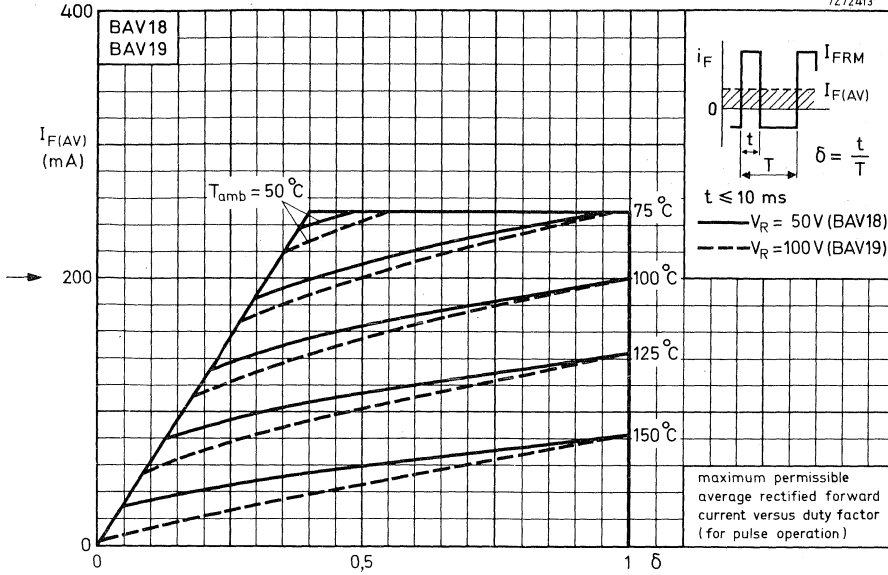

7Z72414

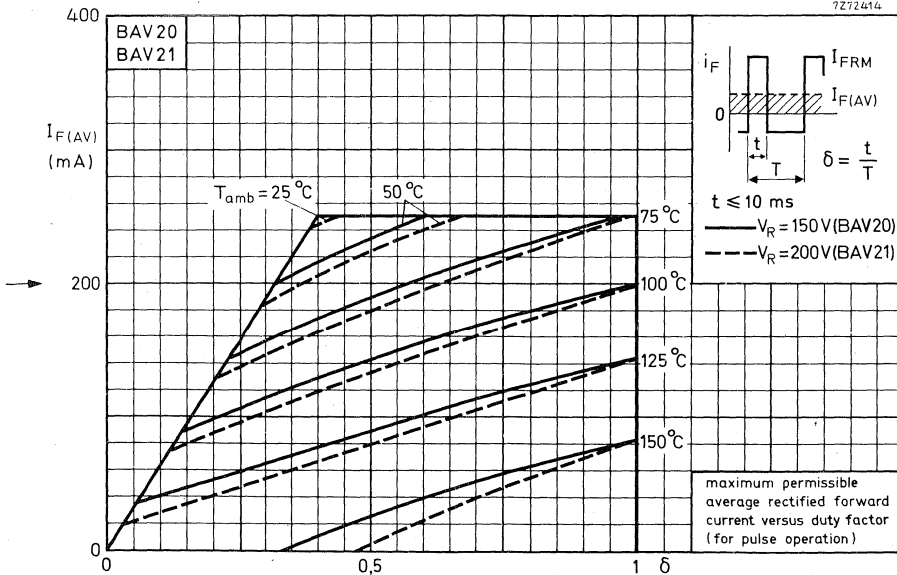

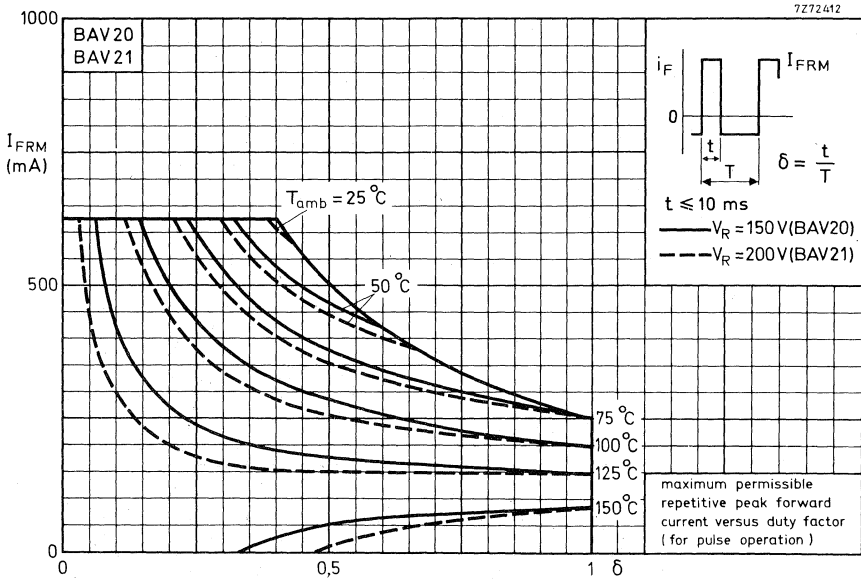
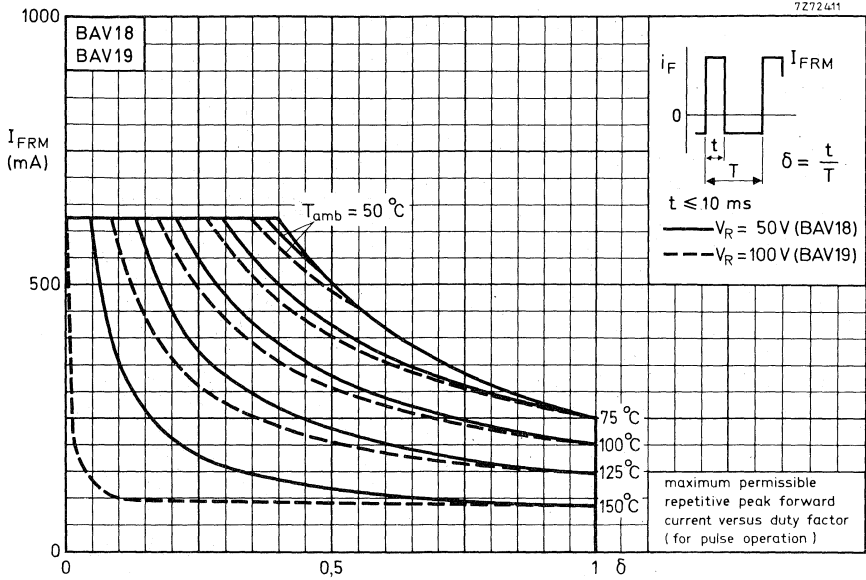

BAV18 to 21

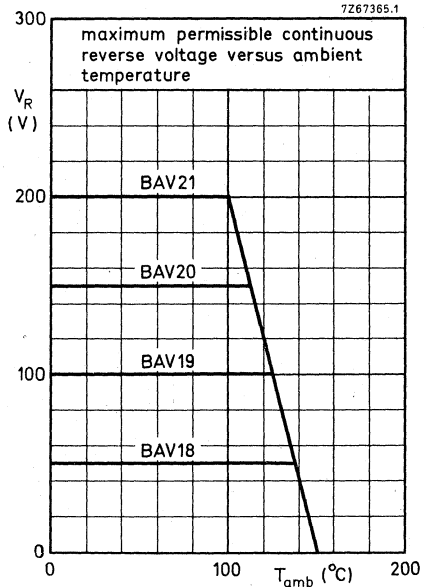
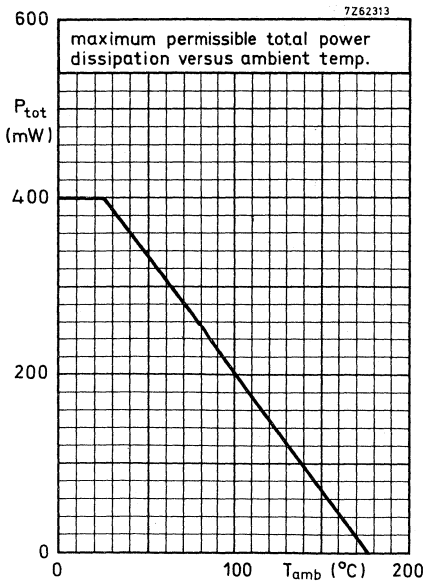
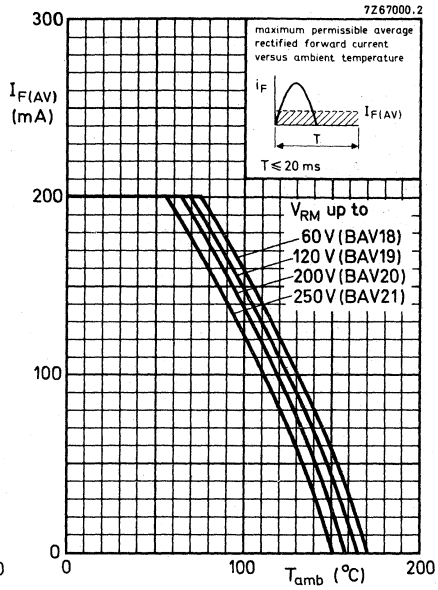
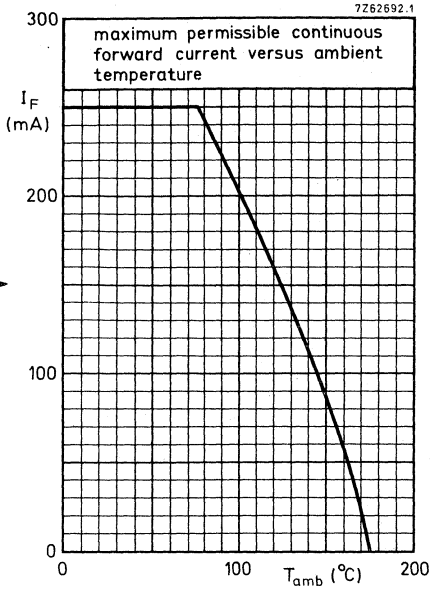

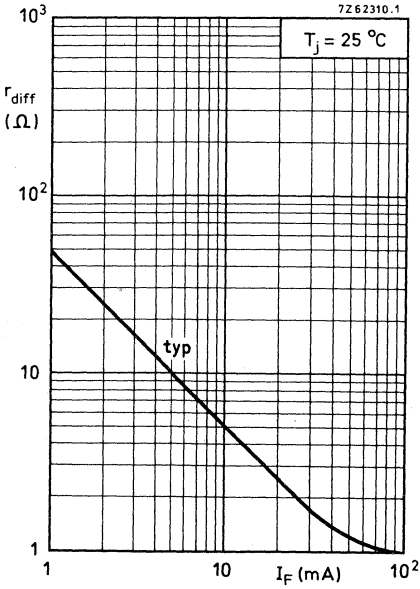
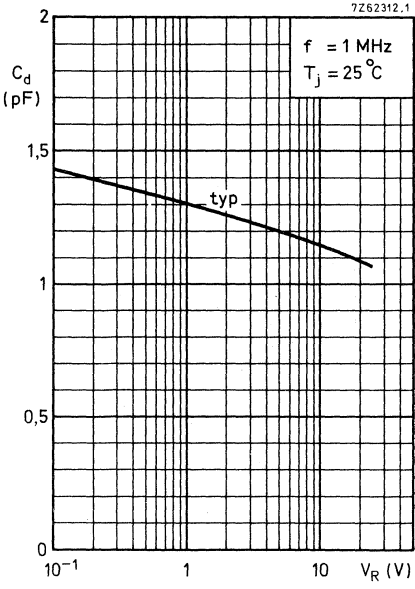
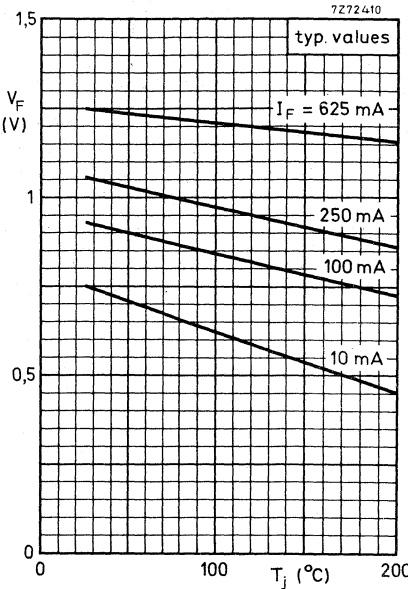
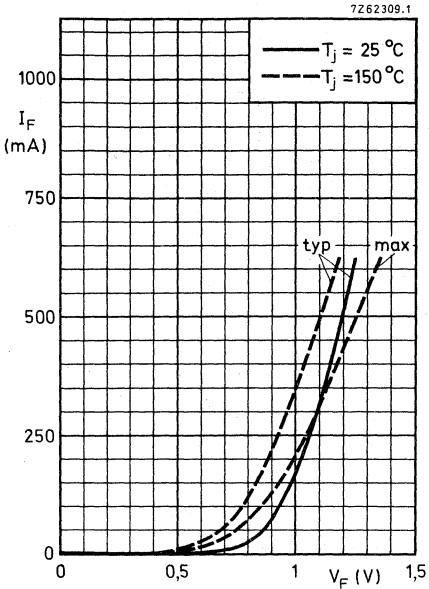

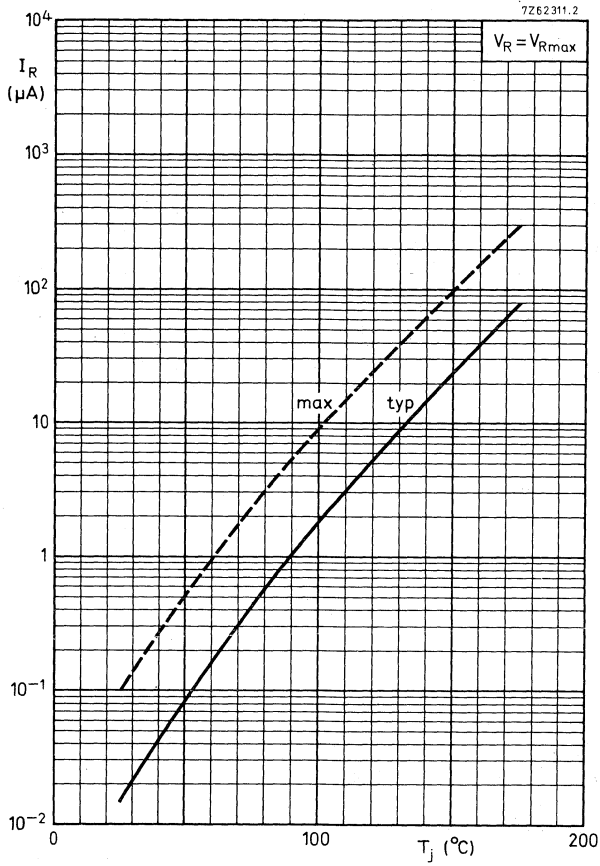

HIGH-SPEED SILICON DIODE

Planar epitaxial high-speed diode in a DO-35 envelope.
 The BAW62 is primarily intended for fast logic applications.

QUICK REFERENCE DATA			
Continuous reverse voltage	V_R	max.	75 V
Repetitive peak reverse voltage	V_{RRM}	max.	75 V
Repetitive peak forward current	I_{FRM}	max.	225 mA
Junction temperature	T_j	max.	200 °C
Forward voltage at $I_F = 100$ mA	V_F	<	1 V
Reverse recovery time when switched from $I_F = 10$ mA to $I_R = 10$ mA; $R_L = 100 \Omega$; measured at $I_R = 1$ mA	t_{rr}	<	4 ns

MECHANICAL DATA

Dimensions in mm

DO-35

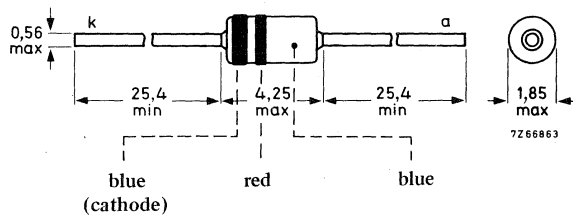

RATINGS Limiting values in accordance with the Absolute Maximum System (IEC 134)

Voltages

Continuous reverse voltage	V_R	max.	75 V
Repetitive peak reverse voltage	V_{RRM}	max.	75 V ¹⁾

Currents

Average rectified forward current	$I_{F(AV)}$	max.	100 mA ²⁾
Forward current (d. c.)	I_F	max.	100 mA
Repetitive peak forward current	I_{FRM}	max.	225 mA
Non-repetitive peak forward current; $t = 1 \mu s$	I_{FSM}	max.	2000 mA
$t = 1 s$	I_{FSM}	max.	500 mA

Temperatures

Storage temperature	T_{stg}	-65 to +200 °C
Junction temperature	T_j	max. 200 °C

THERMAL RESISTANCE

From junction to ambient in free air at maximum lead length	$R_{th j-a}$	=	0,6 °C/mW
---	--------------	---	-----------

CHARACTERISTICS

$T_j = 25 \text{ }^\circ\text{C}$ unless otherwise specified

Forward voltages

$I_F = 5 \text{ mA}$	V_F	0,62 to 0,75 V
$I_F = 100 \text{ mA}$	V_F	< 1,00 V
$I_F = 100 \text{ mA}; T_j = 100 \text{ }^\circ\text{C}$	V_F	< 0,93 V

Reverse currents

$V_R = 20 \text{ V}$	I_R	< 25 nA
$V_R = 20 \text{ V}; T_j = 150 \text{ }^\circ\text{C}$	I_R	< 50 μA
$V_R = 50 \text{ V}$	I_R	< 200 nA
$V_R = 75 \text{ V}$	I_R	< 5 μA
$V_R = 75 \text{ V}; T_j = 150 \text{ }^\circ\text{C}$	I_R	< 100 μA

Diode capacitance

$V_R = 0; f = 1 \text{ MHz}$	C_d	< 2 pF
------------------------------	-------	--------

¹⁾ Measured at zero life time at $I_R = 100 \mu\text{A}; V_R > 100 \text{ V}$.

²⁾ For sinusoidal operation see page 6. For pulse operation see page 5.

CHARACTERISTICS (continued)

$T_j = 25\text{ }^\circ\text{C}$

Forward recovery voltage when switched to

$I_F = 50\text{ mA}$; $t_r = 20\text{ ns}$

$V_{fr} < 2,5\text{ V}$

Test circuit waveforms:

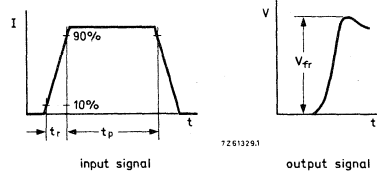
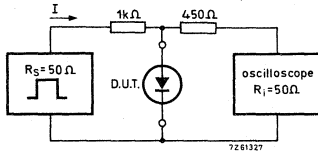

Input signal : Rise time of the forward pulse $t_r = 20\text{ ns}$
 Forward current pulse duration $t_p = 120\text{ ns}$
 Duty factor $\delta = 0,01$

Oscilloscope : Rise time $t_r = 0,35\text{ ns}$

Circuit capacitance $C \leq 1\text{ pF}$ ($C = \text{oscilloscope input capacitance} + \text{parasitic capacitance}$)

Reverse recovery time when switched from

$I_F = 10\text{ mA}$ to $I_R = 10\text{ mA}$; $R_L = 100\text{ }\Omega$;
 measured at $I_R = 1\text{ mA}$

$t_{rr} < 4\text{ ns}$

Test circuit waveforms:

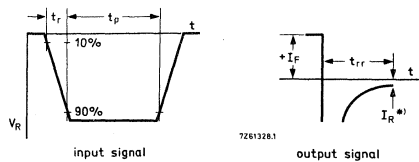
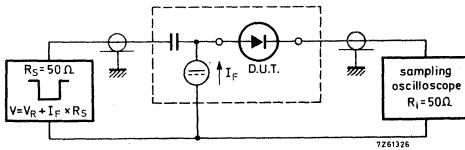

Input signal : Rise time of the reverse pulse $t_r = 0,6\text{ ns}$ $*) I_R = 1\text{ mA}$
 Reverse pulse duration $t_p = 100\text{ ns}$
 Duty factor $\delta = 0,05$

Oscilloscope: Rise time $t_r = 0,35\text{ ns}$

Circuit capacitance $C \leq 1\text{ pF}$ ($C = \text{oscilloscope input capacitance} + \text{parasitic capacitance}$)

CHARACTERISTICS (continued)

$T_j = 25\text{ }^\circ\text{C}$

Recovery charge when switched from

$I_F = 10\text{ mA}$ to $V_R = 5\text{ V}$; $R_L = 500\ \Omega$

Q_S typ. 50 pC

Test circuit and waveform:

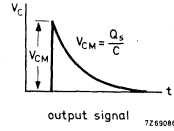
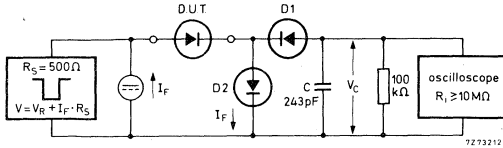

D1 = D2 = BAW62

Input signal : Rise time of the reverse pulse $t_{r} = 2\text{ ns}$

Reverse pulse duration $t_p = 400\text{ ns}$

Duty factor $\delta = 0,02$

Circuit capacitance $C \leq 7\text{ pF}$ ($C = \text{oscilloscope input capacitance} + \text{parasitic capacitance}$)



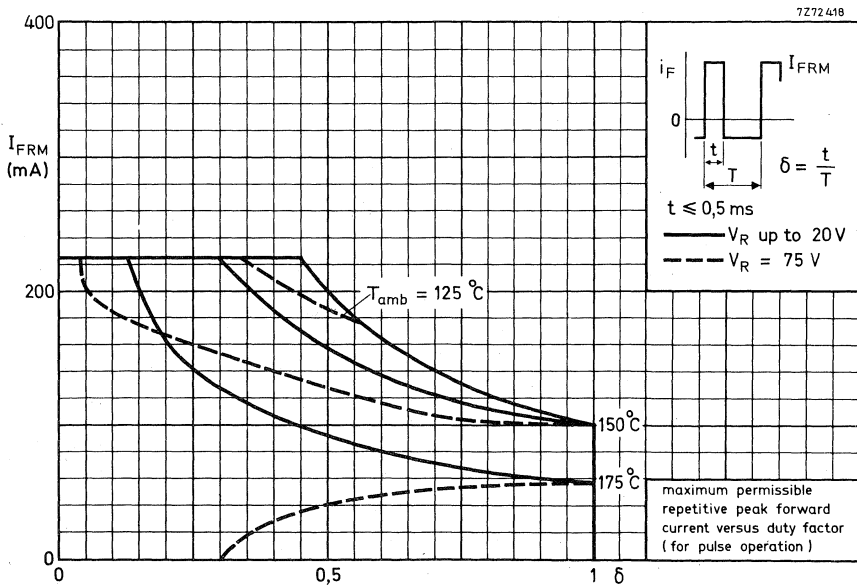
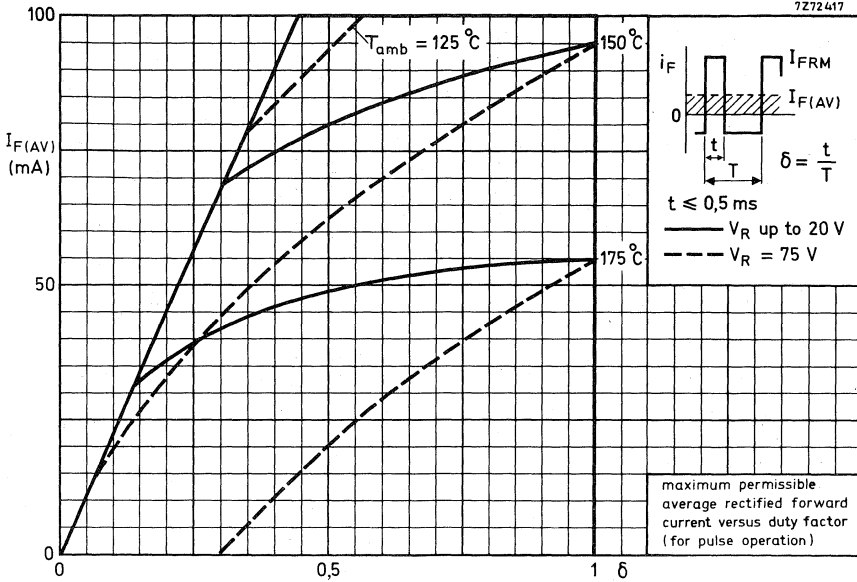

7Z72419

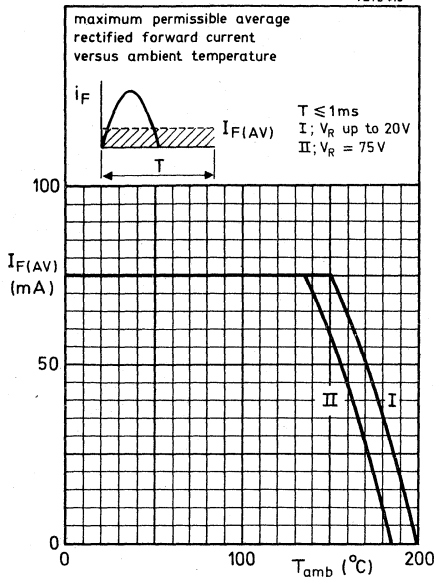

7Z72420

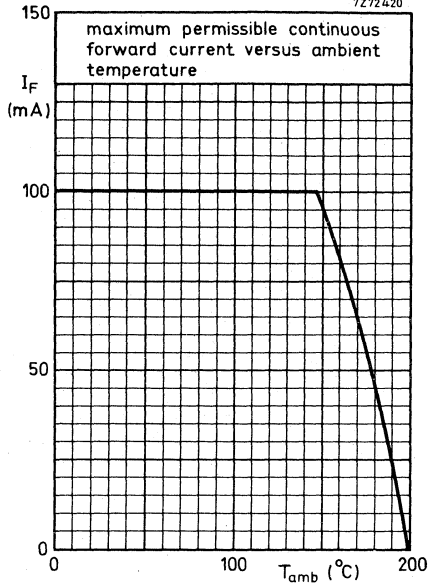

7Z10523

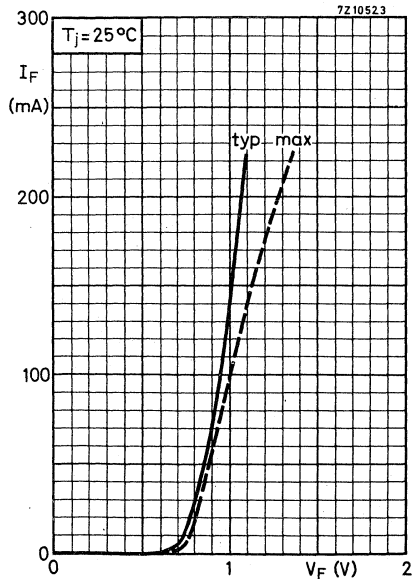

7Z10525.1

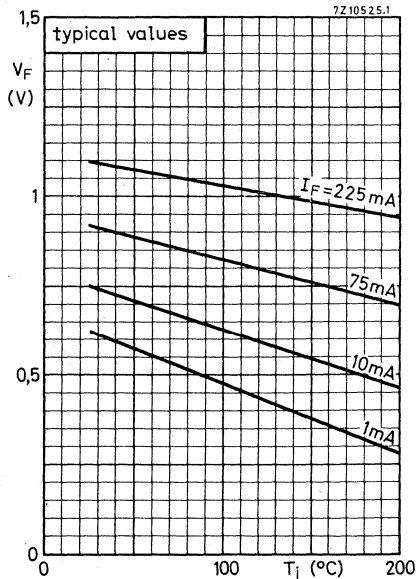

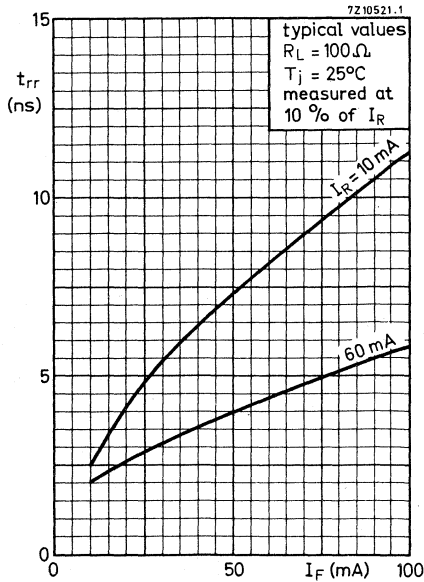
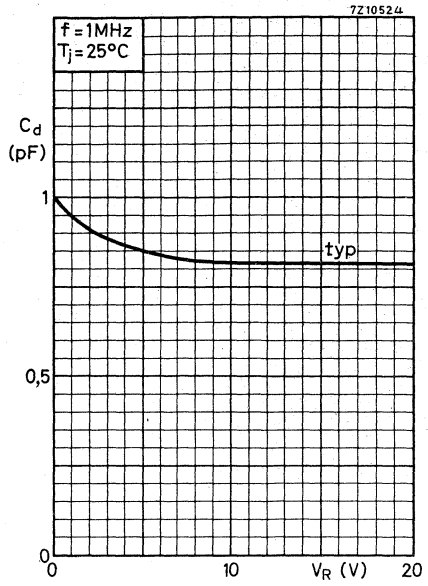
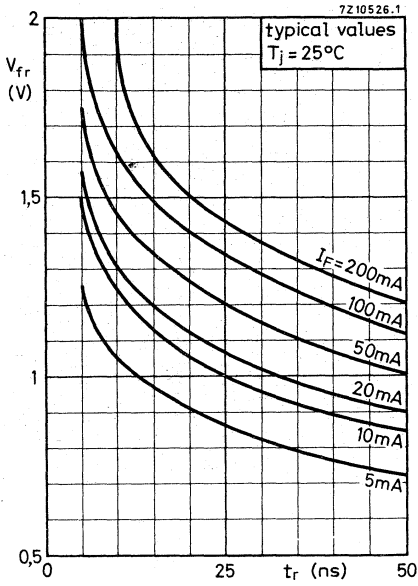

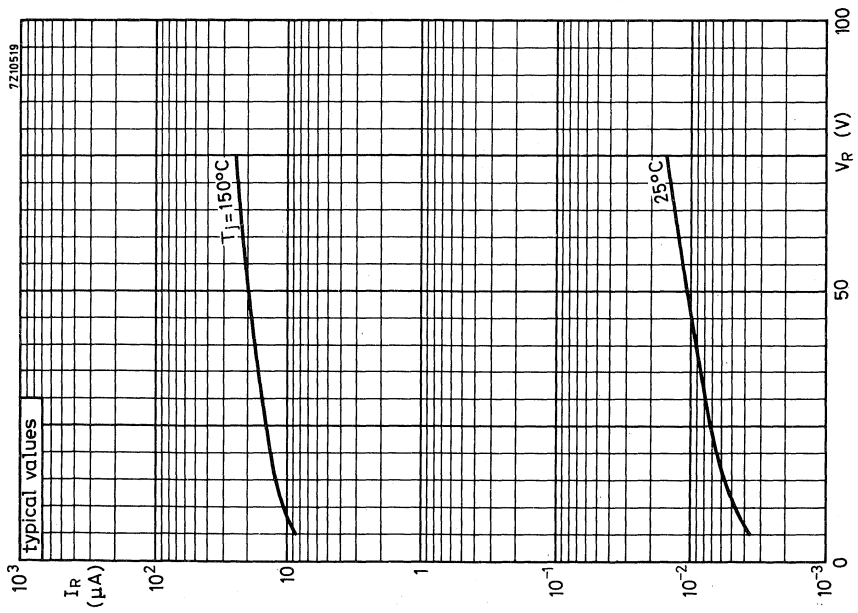
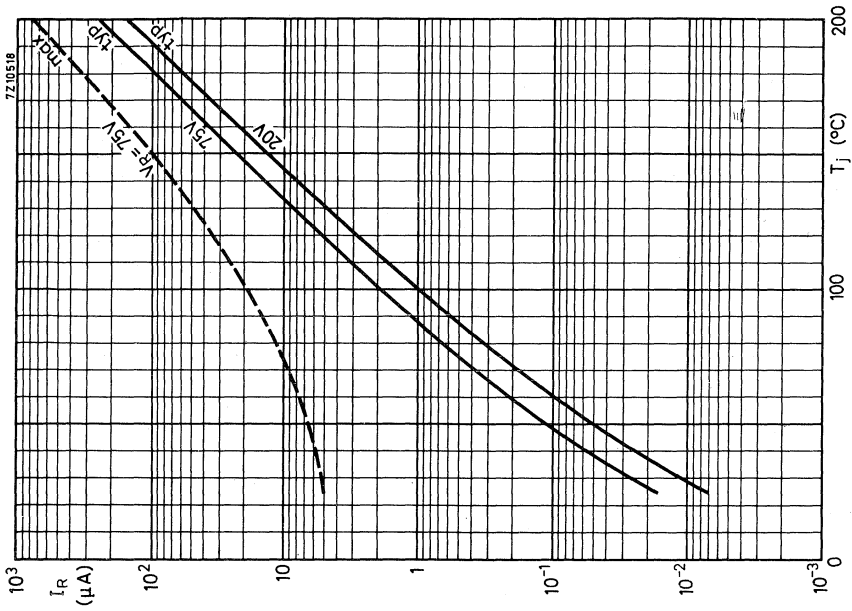

SILICON OXIDE PASSIVATED AVALANCHE DIODE

Whiskerless diffused diode in a molybdenum hard glass subminiature envelope, capable of absorbing transients repetitively. It is a fast high conductance diode, primarily intended for switching inductive loads in semi-electronic telephone exchanges.

QUICK REFERENCE DATA			
Repetitive peak forward current	I_{FRM}	max.	800 mA
Repetitive peak reverse energy $t_p \geq 250 \mu s$; $f \leq 20$ Hz; $T_j = 25 \text{ }^\circ\text{C}$	E_{RRM}	max.	10 mWs
Thermal resistance from junction to ambient	$R_{th j-a}$	=	0,3 $^\circ\text{C}/\text{mW}$
Forward voltage at $I_F = 200$ mA	V_F	<	1,0 V
Reverse avalanche breakdown voltage $I_R = 1$ mA	$V_{(BR)R}$	120 to 175	V
Reverse current $V_R = 90$ V; $T_j = 150 \text{ }^\circ\text{C}$	I_R	<	100 μA
Reverse recovery time when switched from $I_F = 30$ mA to $I_R = 30$ mA; $R_L = 100 \Omega$; measured at $I_R = 3$ mA	t_{rr}	<	50 ns
Recovery charge when switched from $I_F = 10$ mA to $V_R = 5$ V; $R_L = 500 \Omega$	Q_s	<	0,5 nC

MECHANICAL DATA

Dimensions in mm

SOD-17

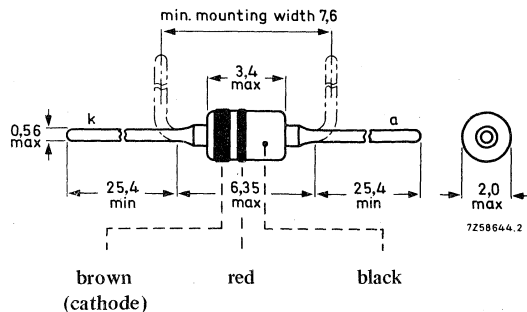

RATINGS Limiting values in accordance with the Absolute Maximum System (IEC 134)

Voltage

Continuous reverse voltage V_R max. 90 V ¹⁾

Currents

Average rectified forward current
(averaged over any 20 ms period) $I_{F(AV)}$ max. 400 mA

Forward current (d. c.) I_F max. 400 mA

Repetitive peak forward current I_{FRM} max. 800 mA

→ Non-repetitive peak forward current; $t = 10 \mu s$ I_{FSM} max. 30 A
 $t = 1 s$ I_{FSM} max. 1,5 A

Repetitive peak reverse current I_{RRM} max. 600 mA

→ Reverse energy (see also page 4)

Repetitive peak reverse energy
 $t_p \geq 250 \mu s$; $f \leq 20$ Hz; $T_j = 25^\circ C$ E_{RRM} max. 10 mWs

Temperatures

Storage temperature T_{stg} -65 to +200 °C

Junction temperature T_j max. 200 °C

THERMAL RESISTANCE

From junction to ambient in free air $R_{th j-a} = 0,3$ °C/mW

CHARACTERISTICS

$T_j = 25^\circ C$ unless otherwise specified

Forward voltage

$I_F = 10$ mA	V_F	<	0,75	V
$I_F = 50$ mA	V_F	<	0,84	V
$I_F = 100$ mA	V_F	<	0,90	V
$I_F = 200$ mA	V_F	<	1,00	V
$I_F = 400$ mA	V_F	<	1,25	V

Reverse avalanche breakdown voltage at $I_R = 1$ mA $V_{(BR)R}$ 120 to 175 V

Reverse current

$V_R = 90$ V; $T_j = 150^\circ C$ I_R < 100 μA

Diode capacitance

$V_R = 0$; $f = 1$ MHz C_d typ. 25 pF
< 35 pF

¹⁾ It is allowed to exceed this value as described on page 4. Care should be taken not to exceed the I_{RRM} rating.

CHARACTERISTICS (continued)

$T_j = 25\text{ }^\circ\text{C}$

Reverse recovery time when switched from

$I_F = 30\text{ mA}$ to $I_R = 30\text{ mA}$; $R_L = 100\text{ }\Omega$;

measured at $I_{R1} = 1\text{ mA}$

t_{rr} typ. 37 ns
 < 60 ns

measured at $I_{R2} = 3\text{ mA}$

t_{rr} typ. 30 ns
 < 50 ns

Test circuit and waveforms:

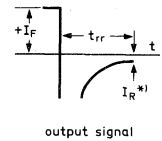
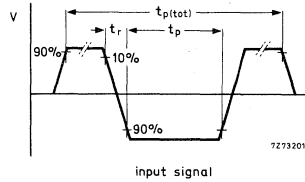
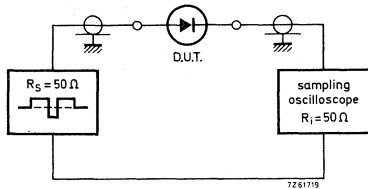

Input signal : Total pulse duration

$t_{p(tot)} = 2\text{ }\mu\text{s}$

*) $I_{R1} = 1\text{ mA}$

Duty factor

$\delta = 0,0025$

$I_{R2} = 3\text{ mA}$

Rise time of the reverse pulse

$t_r = 0,6\text{ ns}$

Reverse pulse duration

$t_p = 100\text{ ns}$

Oscilloscope: Rise time

$t_r = 0,35\text{ ns}$

Circuit capacitance $C \leq 1\text{ pF}$ ($C =$ oscilloscope input capacitance + parasitic capacitance)

Recovery charge when switched from

$I_F = 10\text{ mA}$ to $V_R = 5\text{ V}$; $R_L = 500\text{ }\Omega$

$Q_S < 0,5\text{ nC}$

Test circuit and waveform:

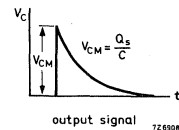
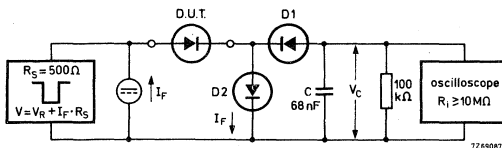

$D1 = D2 = \text{BAW62}$

Input signal : Rise time of the reverse pulse

$t_r = 15\text{ ns}$

Reverse pulse duration

$t_p = 35\text{ }\mu\text{s}$

Frequency

$f = 25\text{ kHz}$

Circuit capacitance $C \leq 30\text{ pF}$ ($C =$ oscilloscope input capacitance + parasitic capacitance)

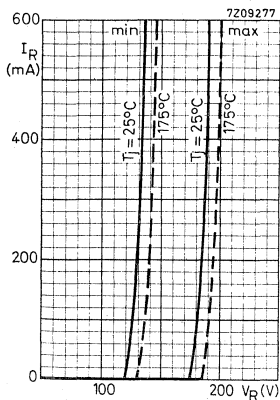

Reverse voltages higher than the V_R ratings are allowed, provided

- a. the transient energy ≤ 10 mWs at $I_R \leq 200$ mA; $T_j = 25^\circ\text{C}$
 the transient energy ≤ 5 mWs at $I_R = 600$ mA; $T_j = 25^\circ\text{C}$ (see graph on page 5)
- b. $T \geq 50$ ms; $\delta \leq 0,01$ (rectangular waveform)
 $\delta \leq 0,02$ (triangular waveform)

With increasing temperature, the maximum permissible transient energy must be decreased by 0,015 mWs/ $^\circ\text{C}$.

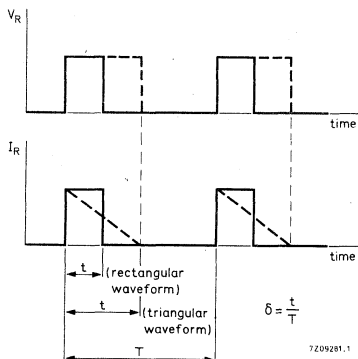

Example for calculating the maximum permissible drive current and the max. turn-off time in a practical circuit (see Fig. 1)

1. Maximum permissible drive current

For the circuit shown it can be calculated with $E = \frac{1}{2} L I^2$

$$I_{\text{drive max.}} = \sqrt{\frac{10 \times 10^{-3}}{\frac{1}{2} \times 0,5}} = 200 \text{ mA}$$

2. Maximum turn-off time

Immediately after opening switch S the reverse current of the diode is $I_R = I_{\text{drive}}$.

The turn-off time $t_{\text{off}} = \frac{E}{\frac{1}{2} \times I_R \times V_{(\text{BR})R}}$. It will be max. for devices with minimum breakdown voltage if the maximum drive current is applied.

$$\text{Hence } t_{\text{off max.}} = \frac{10 \times 10^{-3}}{\frac{1}{2} \times 200 \times 10^{-3} \times 120} = 0,8 \text{ ms}$$

$$\text{For } I_{\text{drive}} = 100 \text{ mA: } t_{\text{off max.}} = \frac{\frac{1}{2} \times 0,5 \times 10^{-2}}{\frac{1}{2} \times 100 \times 10^{-3} \times 120} = 0,4 \text{ ms.}$$

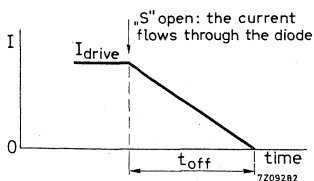

Fig. 1

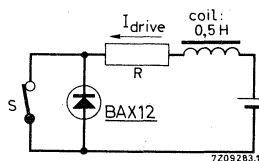
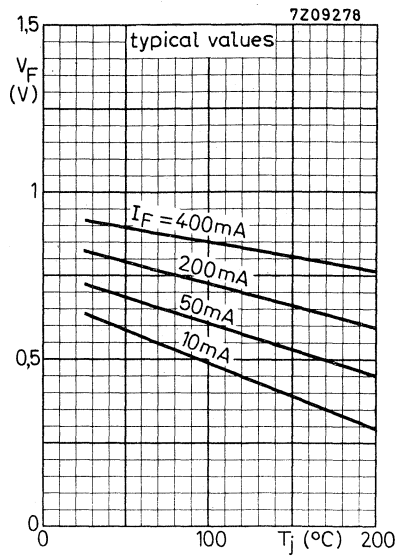
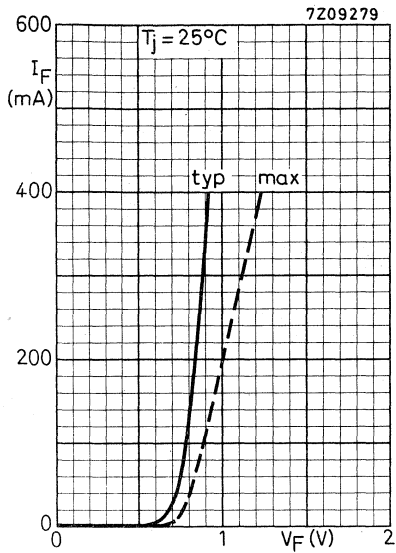
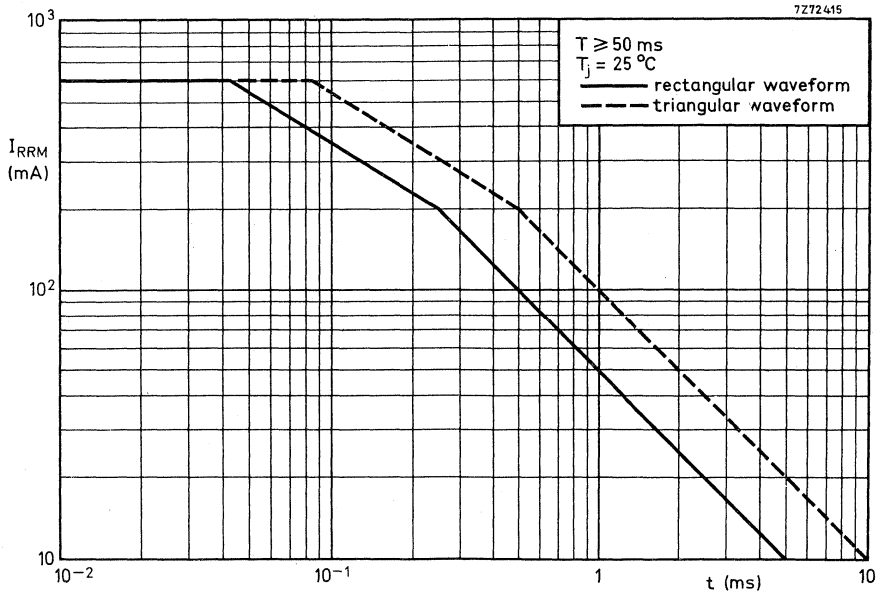
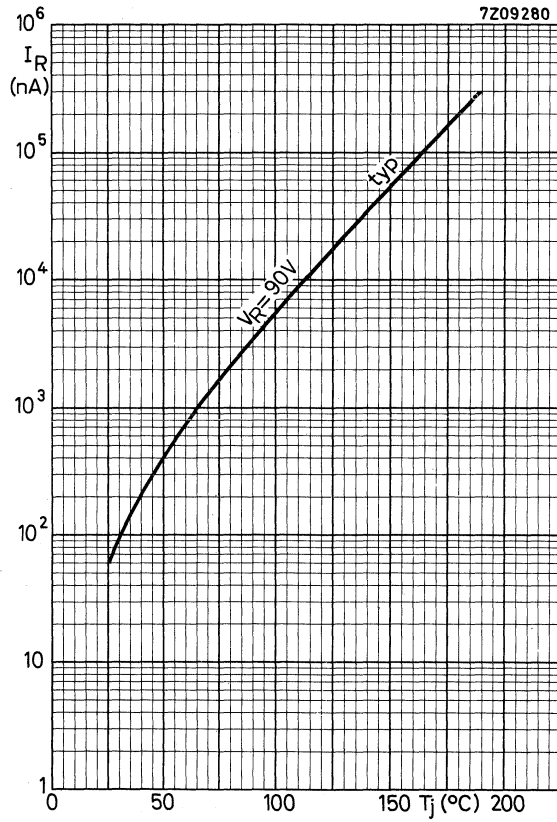

Fig. 2



maximum permissible repetitive peak reverse current versus pulse duration





SILICON OXIDE PASSIVATED DIODE

Whiskerless diode in a hard glass subminiature envelope.
 The BAX13 is primarily intended for general purpose applications.

QUICK REFERENCE DATA			
Continuous reverse voltage	V_R	max.	50 V
Repetitive peak reverse voltage	V_{RRM}	max.	50 V
Repetitive peak forward current	I_{FRM}	max.	150 mA
Thermal resistance from junction to ambient	$R_{th\ j-a}$	=	0,60 °C/mW
Forward voltage at $I_F = 20\text{ mA}$	V_F	<	1,0 V
Reverse recovery time when switched from $I_F = 10\text{ mA}$ to $I_R = 60\text{ mA}$; $R_L = 100\ \Omega$; measured at $I_R = 1\text{ mA}$	t_{rr}	<	4 ns
Recovery charge when switched from $I_F = 10\text{ mA}$ to $V_R = 5\text{ V}$; $R_L = 500\ \Omega$	Q_S	<	45 pC

MECHANICAL DATA

Dimensions in mm

SOD-17

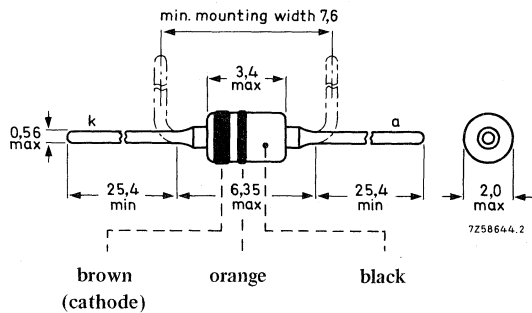

RATINGS Limiting values in accordance with the Absolute Maximum System (IEC 134)Voltages

Continuous reverse voltage	V_R	max.	50	V
Repetitive peak reverse voltage	V_{RRM}	max.	50	V

Currents

Average rectified forward current (averaged over any 20 ms period)	$I_{F(AV)}$	max.	75	mA ¹⁾
Forward current (d. c.)	I_F	max.	75	mA
Repetitive peak forward current	I_{FRM}	max.	150	mA
Non-repetitive peak forward current t = 1 μ s	I_{FSM}	max.	2000	mA
t = 1 s	I_{FSM}	max.	500	mA

Temperatures

Storage temperature	T_{stg}	-65 to +200	$^{\circ}$ C
Junction temperature	T_j	max. 200	$^{\circ}$ C

THERMAL RESISTANCE

From junction to ambient in free air	$R_{th\ j-a}$	=	0,60	$^{\circ}$ C/mW
--------------------------------------	---------------	---	------	-----------------

CHARACTERISTICS $T_j = 25\ ^{\circ}$ C unless otherwise specifiedForward voltage

$I_F = 2\ \text{mA}$	V_F	<	0,7	V
$I_F = 10\ \text{mA}; T_j = 100\ ^{\circ}\text{C}$	V_F	<	0,8	V
$I_F = 20\ \text{mA}$	V_F	<	1,0	V ²⁾
$I_F = 75\ \text{mA}$	V_F	<	1,53	V ²⁾

Reverse current

$V_R = 10\ \text{V}$	I_R	<	25	nA
$V_R = 10\ \text{V}; T_j = 150\ ^{\circ}\text{C}$	I_R	<	10	μ A
$V_R = 25\ \text{V}$	I_R	<	50	nA
$V_R = 50\ \text{V}$	I_R	<	200	nA
$V_R = 50\ \text{V}; T_j = 150\ ^{\circ}\text{C}$	I_R	<	25	μ A

Diode capacitance (see also page 7)

$V_R = 0; f = 1\ \text{MHz}$	C_d	<	3	pF
------------------------------	-------	---	---	----

¹⁾ For sinusoidal operation see page 5.
For pulse operation see page 6.

²⁾ Measured under pulse conditions to avoid excessive dissipation.

CHARACTERISTICS (continued)

$T_j = 25\text{ }^\circ\text{C}$

Forward recovery voltage (see also page 7)

At $t_R > 20\text{ ns}$, V_{FR} will not exceed V_F corresponding to $I_F = 1\text{ to }75\text{ mA}$

Test circuit and waveforms :

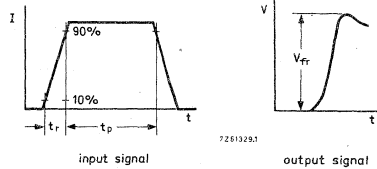
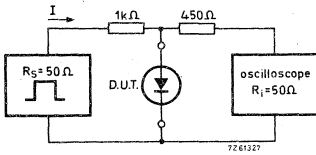

Input signal : Rise time of the forward pulse $t_R = 20\text{ ns}$
 Forward current pulse duration $t_p = 120\text{ ns}$
 Duty factor $\delta = 0,01$

Oscilloscope : Rise time $t_R = 0,35\text{ ns}$

Circuit capacitance $C \leq 1\text{ pF}$ ($C = \text{oscilloscope input capacitance} + \text{parasitic capacitance}$)

Reverse recovery time when switched from

$I_F = 10\text{ mA}$ to $I_R = 10\text{ mA}$; $R_L = 100\text{ }\Omega$; measured at $I_R = 1\text{ mA}$
 $I_F = 10\text{ mA}$ to $I_R = 60\text{ mA}$; $R_L = 100\text{ }\Omega$; measured at $I_R = 1\text{ mA}$

$t_{RR} < 6\text{ ns}$ 1)
 $t_{RR} < 4\text{ ns}$

Test circuit and waveforms :

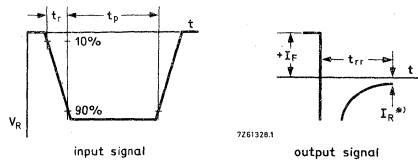
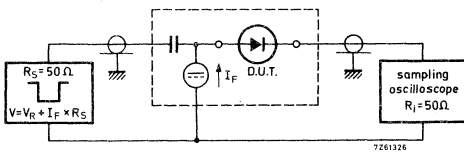

Input signal : Rise time of the reverse pulse $t_R = 0,6\text{ ns}$ *) $I_R = 1\text{ mA}$
 Reverse pulse duration $t_p = 100\text{ ns}$
 Duty factor $\delta = 0,05$

Oscilloscope : Rise time $t_R = 0,35\text{ ns}$

Circuit capacitance $C \leq 1\text{ pF}$ ($C = \text{oscilloscope input capacitance} + \text{parasitic capacitance}$)

1) See also page 8.

CHARACTERISTICS (continued)

$T_j = 25\text{ }^\circ\text{C}$

Recovery charge when switched from

$I_F = 10\text{ mA}$ to $V_R = 5\text{ V}$; $R_L = 500\ \Omega$

$Q_S < 45\text{ pC}$

Test circuit and waveform:

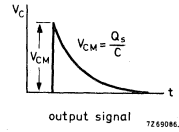
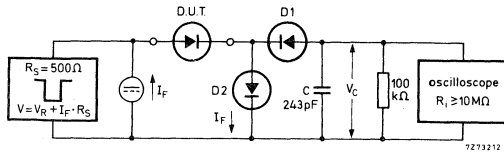

$D1 = D2 = \text{BAW62}$

Input signal: Rise time of the reverse pulse

$t_r = 2\text{ ns}$

Reverse pulse duration

$t_p = 400\text{ ns}$

Duty factor

$\delta = 0,02$

Circuit capacitance $C \leq 7\text{ pF}$ ($C = \text{oscilloscope input capacitance} + \text{parasitic capacitance}$)



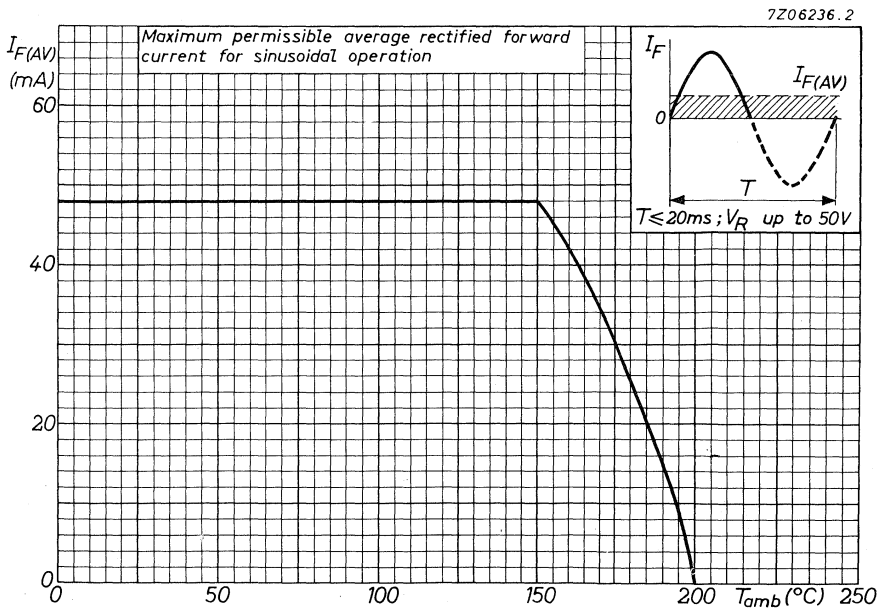
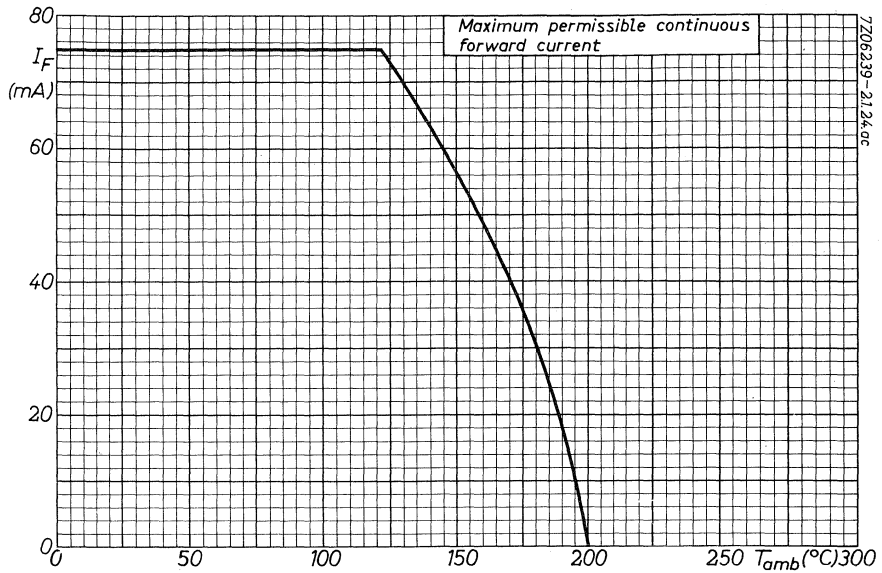

7272423

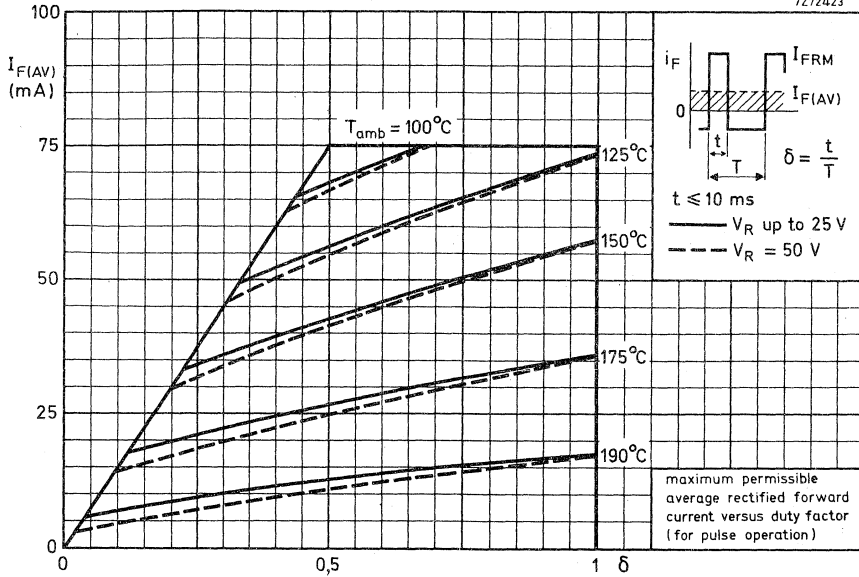

7272424

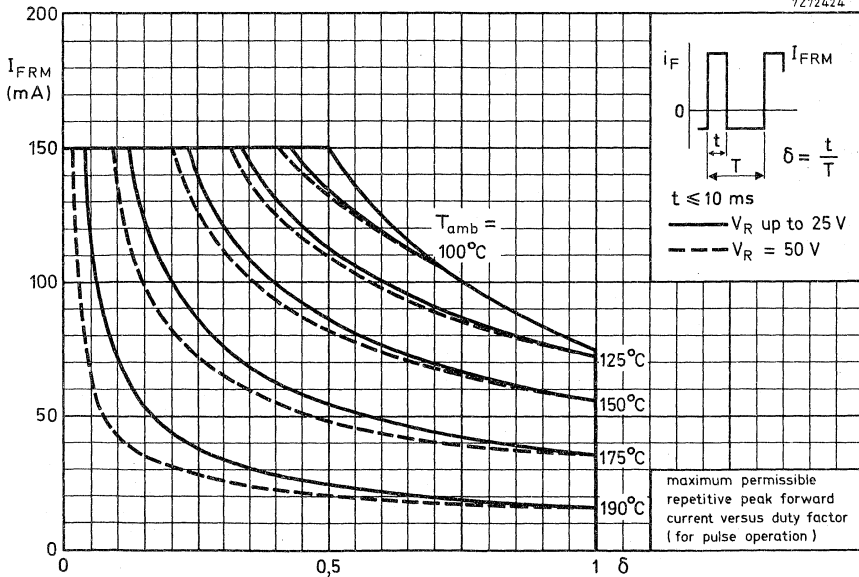

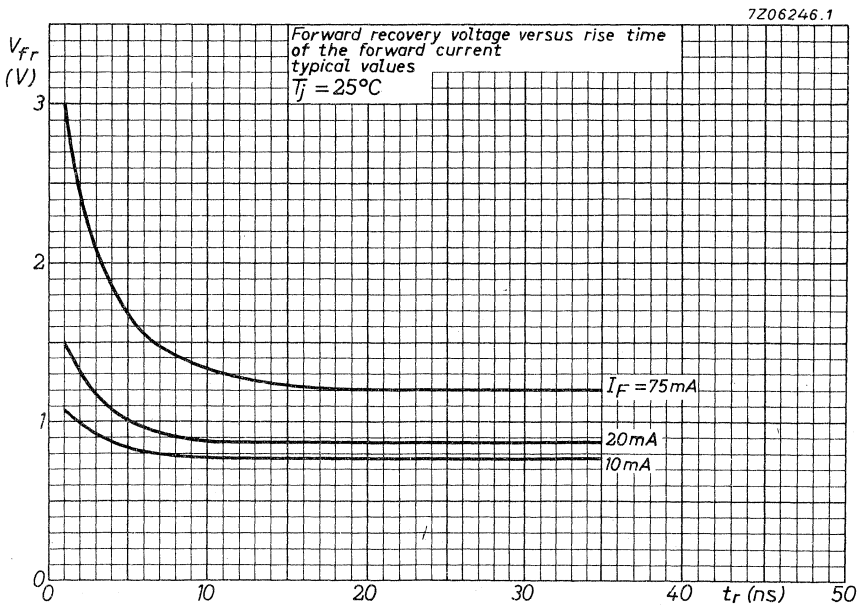
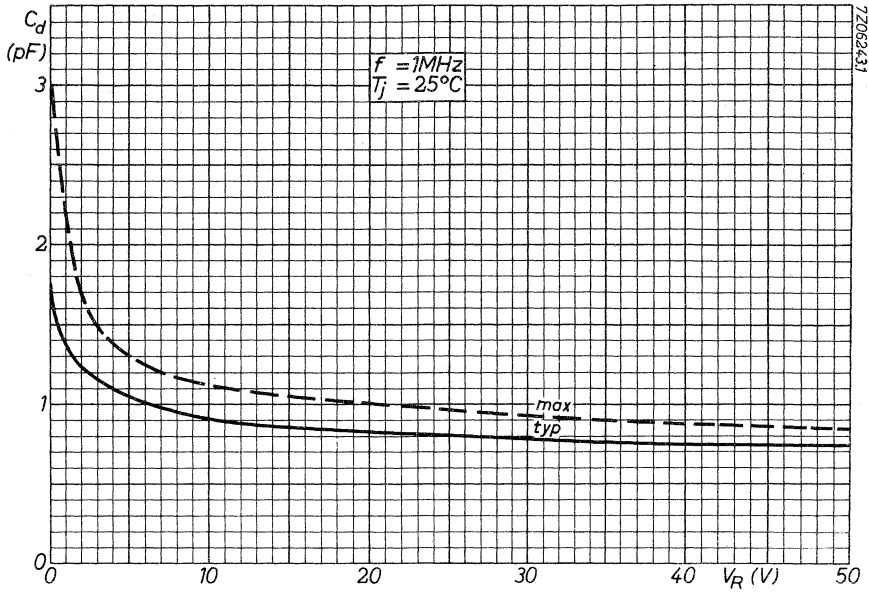

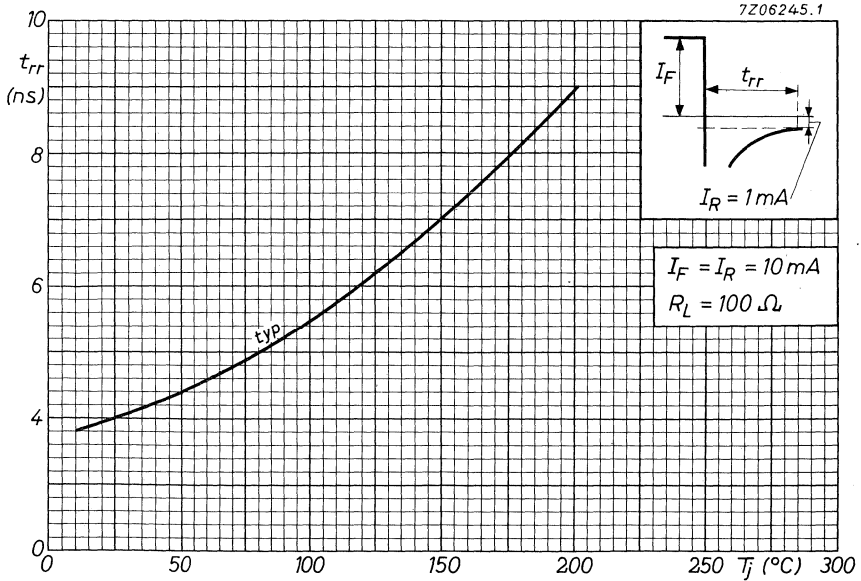
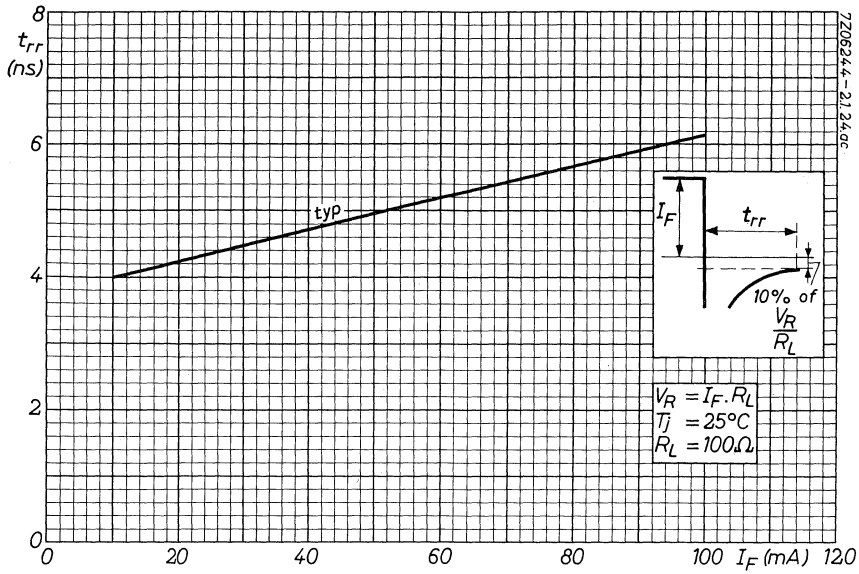

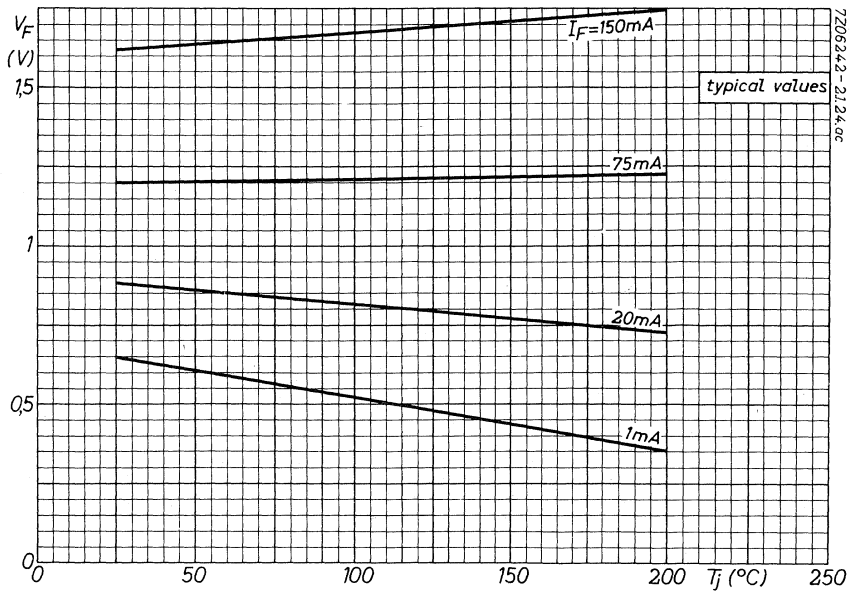
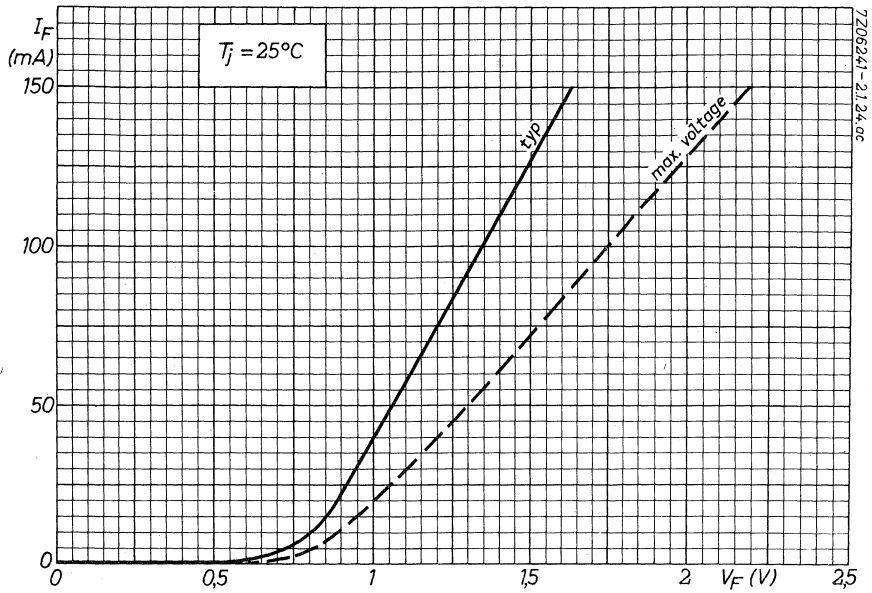

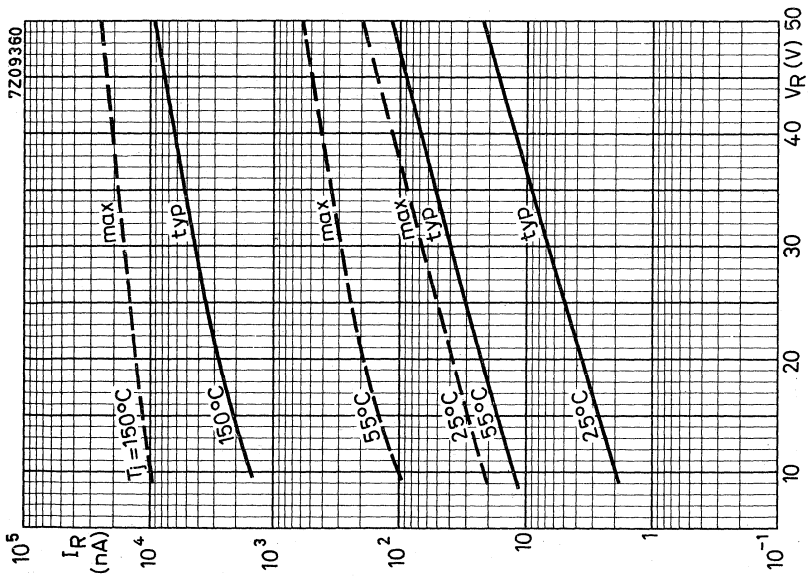
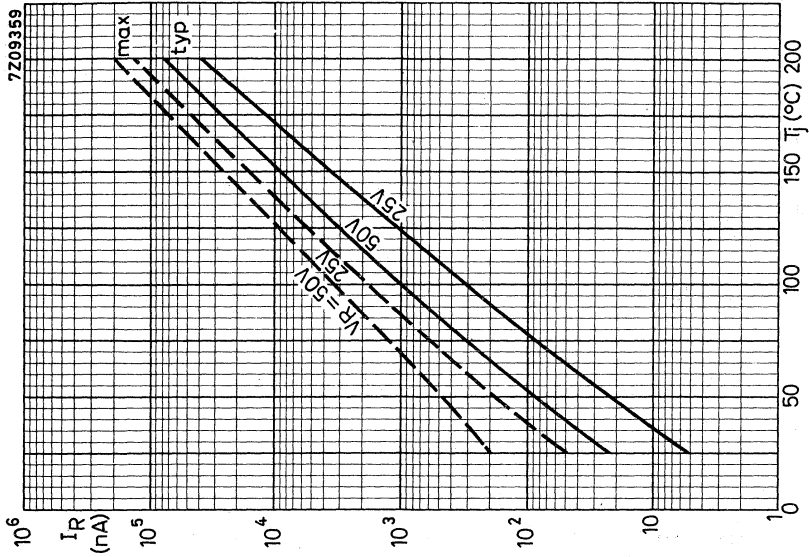

SILICON OXIDE PASSIVATED DIODE

Whiskerless diffused diode in a hard glass subminiature envelope.
It is a general purpose diode also intended for rectifier applications.

QUICK REFERENCE DATA			
Repetitive peak reverse voltage	V_{RRM}	max.	40 V
Average forward current	$I_{F(AV)}$	max.	350 mA
Non-repetitive peak forward current	I_{FSM}	max.	6,0 A
Reverse recovery time when switched from $I_F = 30 \text{ mA}$ to $I_R = 30 \text{ mA}$; $R_L = 100 \Omega$; measured at $I_R = 3 \text{ mA}$	t_{rr}	<	50 ns

MECHANICAL DATA

Dimensions in mm

SOD-17

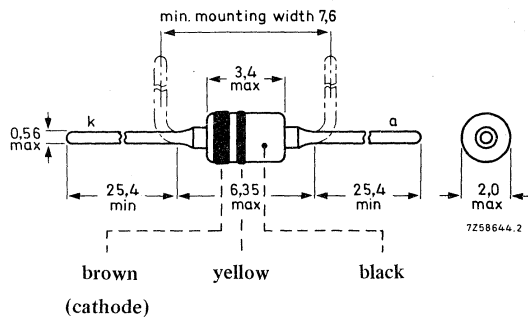

RATINGS Limiting values in accordance with the Absolute Maximum System (IEC 134)Voltages

Repetitive peak reverse voltage	V_{RRM}	max.	40	V
Continuous reverse voltage	V_R	max.	20	V

→ Currents

Forward current (d. c.)	I_F	max.	500	mA
Average forward current (averaged over any 20 ms period; see also page 4)	$I_{F(AV)}$	max.	350	mA
Repetitive peak forward current	I_{FRM}	max.	2,0	A
Non-repetitive peak forward current ($t = 10$ ms; half sine wave) $T_j = 25$ °C prior to surge	I_{FSM}	max.	6,0	A

Temperatures

Storage temperature	T_{stg}	-65 to +200	°C
Junction temperature	T_j	max.	200 °C

→ **THERMAL RESISTANCE**

From junction to ambient in free air at maximum lead length	$R_{th\ j-a}$	=	0,3	°C/mW
--	---------------	---	-----	-------

CHARACTERISTICS

$T_j = 25\text{ }^\circ\text{C}$ unless otherwise specified

Forward voltage

$I_F = 1\text{ mA}$

$I_F = 300\text{ mA}$

$I_F = 2000\text{ mA}; T_j = 150\text{ }^\circ\text{C}$

$V_F = 540\text{ to }600\text{ mV}$

$V_F = 800\text{ to }1100\text{ mV } 1)$

$V_F < 2000\text{ mV } 1) \leftarrow$

Reverse current

$V_R = 20\text{ V}$

$V_R = 40\text{ V}; T_j = 150\text{ }^\circ\text{C}$

$I_R < 100\text{ nA}$

$I_R < 100\text{ }\mu\text{A} \leftarrow$

Diode capacitance

$V_R = 0; f = 1\text{ MHz}$

C_d typ. 25 pF
 $< 35\text{ pF}$

Reverse recovery time when switched from

$I_F = 30\text{ mA to } I_R = 30\text{ mA}; R_L = 100\text{ }\Omega$;
 measured at $I_R = 3\text{ mA}$

$t_{rr} < 50\text{ ns} \leftarrow$

Test circuit and waveforms :

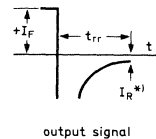
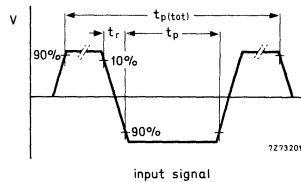
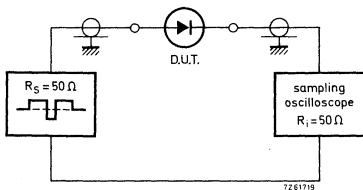

Input signal : Total pulse duration

$t_{p(tot)} = 2\text{ }\mu\text{s}$

*) $I_R = 3\text{ mA}$

Duty factor

$\delta = 0,0025$

Rise time of the reverse pulse

$t_r = 0,6\text{ ns}$

Reverse pulse duration

$t_p = 100\text{ ns}$

Oscilloscope: Rise time

$t_r = 0,35\text{ ns}$

Circuit capacitance $C \leq 1\text{ pF}$ ($C =$ oscilloscope input capacitance + parasitic capacitance)

1) Measured under pulse conditions to avoid excessive dissipation.

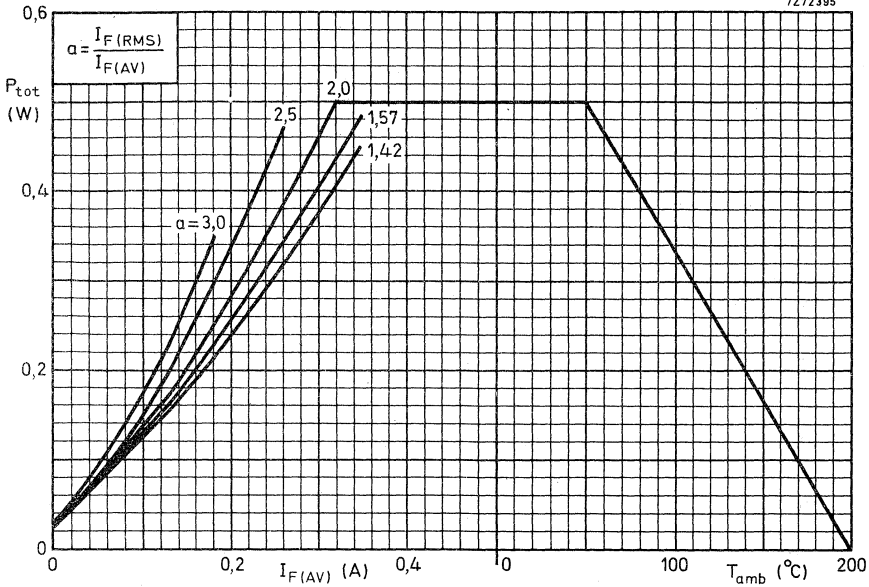

From the left-hand graph the total power dissipation can be found as a function of the average output current.

The parameter $\alpha = \frac{I_F(RMS) \text{ per diode}}{I_F(AV) \text{ per diode}}$ depends on $n\omega R_L C_L$ and $\frac{R_t + r_{diff}}{nR_L}$ and can be

found from existing graphs.

See Application Book : RECTIFIER DIODES.

Once the power dissipation is known, the max. permissible ambient temperature follows from the right-hand graph.

For the series resistance, added to limit the initial peak rectifier current, the required minimum value can be found from the upper graph on page 5.

The value of r_{diff} can be found from the left-hand graph on page 6.

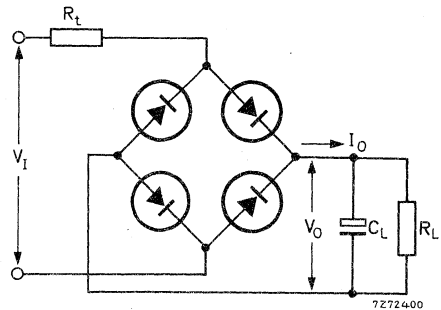
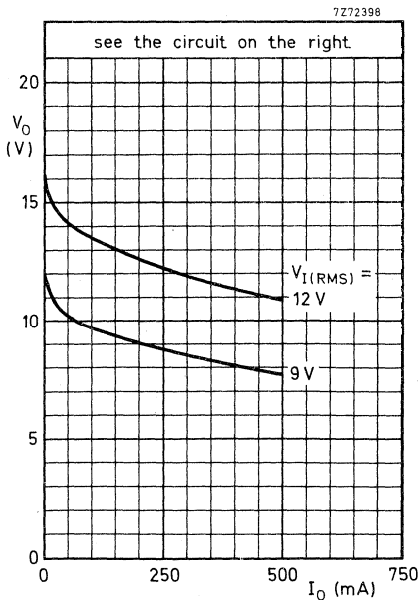
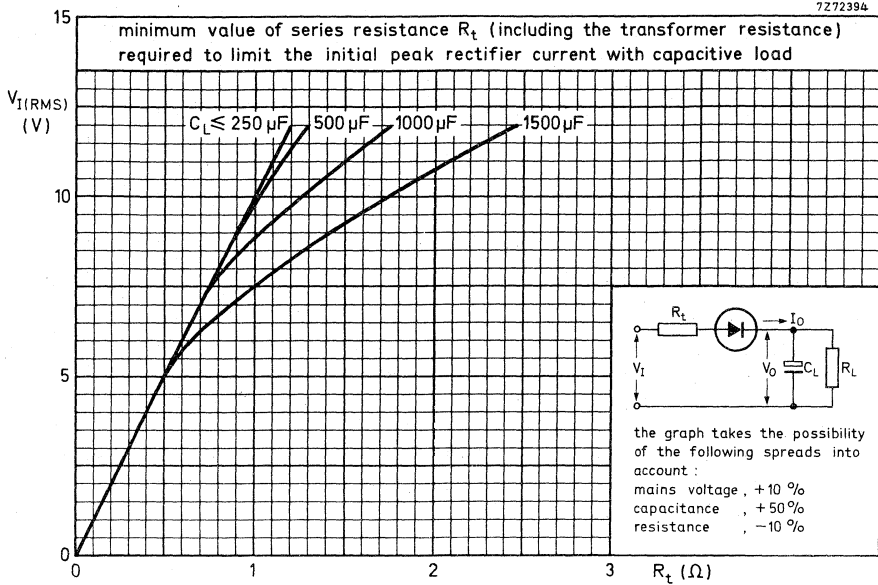

V_I (V)	R_t (Ω)	C_L (μF)
12	1,7	1000
9	1,1	1000

7Z72396

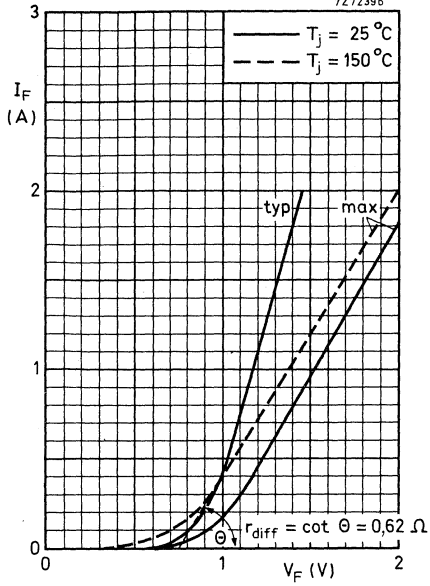

7Z72397

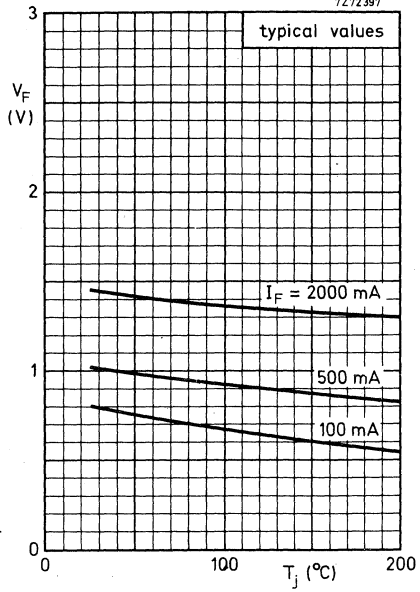

SILICON OXIDE PASSIVATED DIODE

Whiskerless diode in a subminiature envelope. The BAX15 is primarily intended for general purpose industrial applications.

QUICK REFERENCE DATA			
Continuous reverse voltage	V_R	max.	150 V
Repetitive peak reverse voltage	V_{RRM}	max.	180 V
Repetitive peak forward current	I_{FRM}	max.	500 mA
Thermal resistance from junction to ambient	$R_{th j-a}$	=	0,4 °C/mW
Forward voltage at $I_F = 100$ mA	V_F	<	1,0 V
Reverse recovery time when switched from $I_F = 30$ mA to $I_R = 30$ mA; $R_L = 100 \Omega$; measured at $I_R = 3$ mA	t_{rr}	<	300 ns
Recovery charge when switched from $I_F = 10$ mA to $V_R = 5$ V; $R_L = 500 \Omega$	Q_s	typ.	1 nC

MECHANICAL DATA

Dimensions in mm

SOD-17

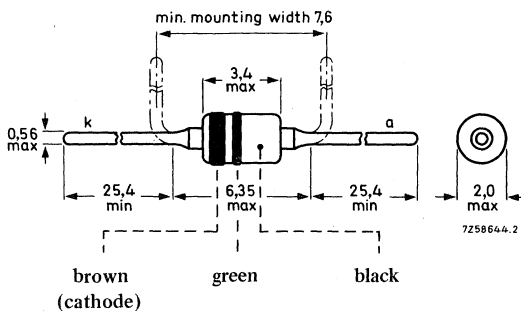

RATINGS Limiting values in accordance with the Absolute Maximum System (IEC 134)Voltages

Continuous reverse voltage	V_R	max.	150	V
Repetitive peak reverse voltage	V_{RRM}	max.	180	V

Currents

Average rectified forward current (averaged over any 20 ms period)	$I_{F(AV)}$	max.	250	mA ¹⁾
Forward current (d. c.)	I_F	max.	250	mA
Repetitive peak forward current	I_{FRM}	max.	500	mA
Non-repetitive peak forward current; $t \leq 10 \mu s$	I_{FSM}	max.	30	A

Temperatures

Storage temperature	T_{stg}	-65 to +200	°C
Junction temperature	T_j	max. 200	°C

THERMAL RESISTANCE

From junction to ambient in free air	$R_{th j-a}$	=	0,4	°C/mW
--------------------------------------	--------------	---	-----	-------

CHARACTERISTICS $T_j = 25 \text{ }^\circ\text{C}$ unless otherwise specifiedForward voltage

$I_F = 100 \text{ mA}$	V_F	<	1,00	V
$I_F = 100 \text{ mA}; T_j = 100 \text{ }^\circ\text{C}$	V_F	<	0,92	V
$I_F = 250 \text{ mA}$	V_F	<	1,35	V

Reverse current

$V_R = 150 \text{ V}$	I_R	<	200	nA
$V_R = 150 \text{ V}; T_j = 100 \text{ }^\circ\text{C}$	I_R	<	10	μA

Diode capacitance (see also page 7)

$V_R = 0; f = 1 \text{ MHz}$	C_d	<	20	pF
------------------------------	-------	---	----	----

1) For sinusoidal operation see page 5.

→ For pulse operation see page 4.

CHARACTERISTICS (continued)

$T_j = 25\text{ }^\circ\text{C}$

Reverse recovery time when switched from

$I_F = 30\text{ mA}$ to $I_R = 30\text{ mA}$; $R_L = 100\ \Omega$;

measured at $I_R = 3\text{ mA}$

$t_{rr} < 300\text{ ns}$

Test circuit and waveforms :

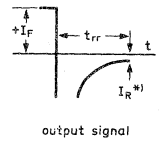
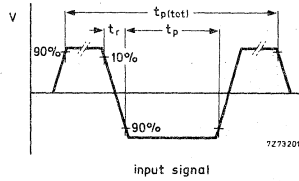
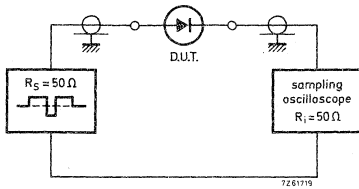

Input signal : Total pulse duration

$t_{p(tot)} = 10\ \mu\text{s}$

*) $I_R = 3\text{ mA}$

Duty factor

$\delta = 0,0025$

Rise time of the reverse pulse

$t_r = 0,6\text{ ns}$

Reverse pulse duration

$t_p = 300\text{ ns}$

Oscilloscope : Rise time

$t_r = 0,35\text{ ns}$

Circuit capacitance $C \leq 1\text{ pF}$ ($C =$ oscilloscope input capacitance + parasitic capacitance)

Recovery charge when switched from

$I_F = 10\text{ mA}$ to $V_R = 5\text{ V}$; $R_L = 500\ \Omega$

Q_S typ. 1 nC

Test circuit and waveform:

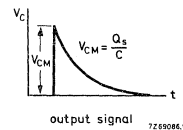
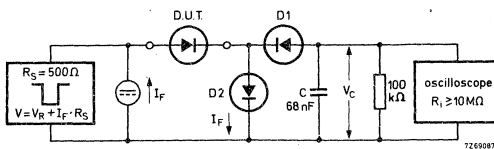

$D1 = D2 = \text{BAW62}$

Input signal : Rise time of the reverse pulse

$t_r = 15\text{ ns}$

Reverse pulse duration

$t_p = 35\ \mu\text{s}$

Frequency

$f = 25\text{ kHz}$

Circuit capacitance $C \leq 30\text{ pF}$ ($C =$ oscilloscope input capacitance + parasitic capacitance)

7Z72428

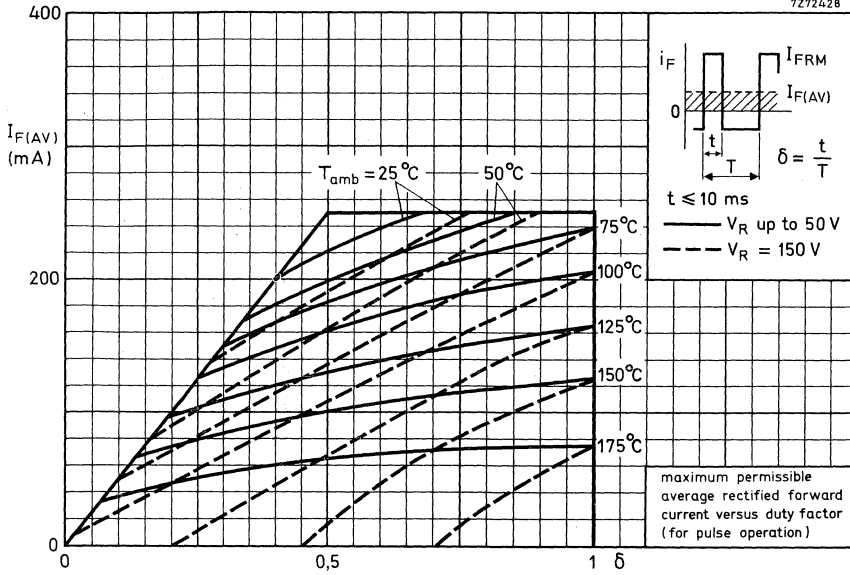

7Z72427

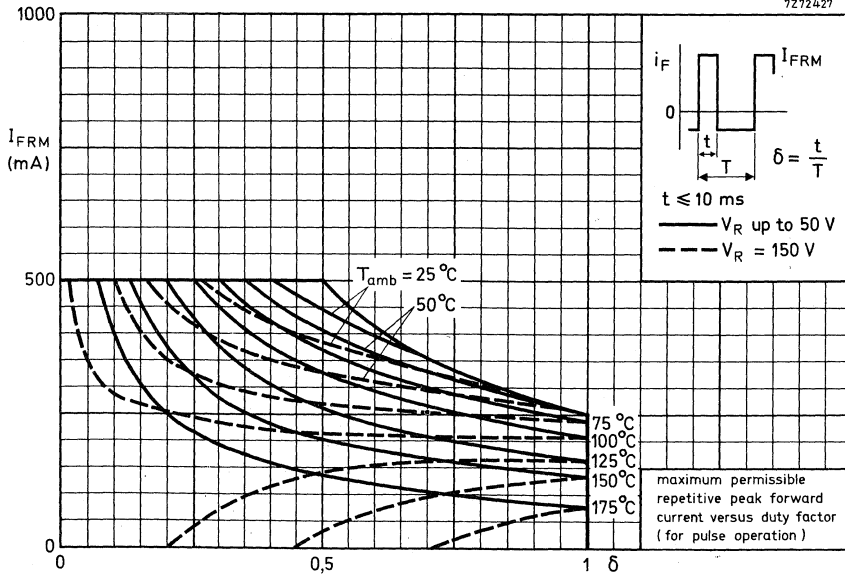

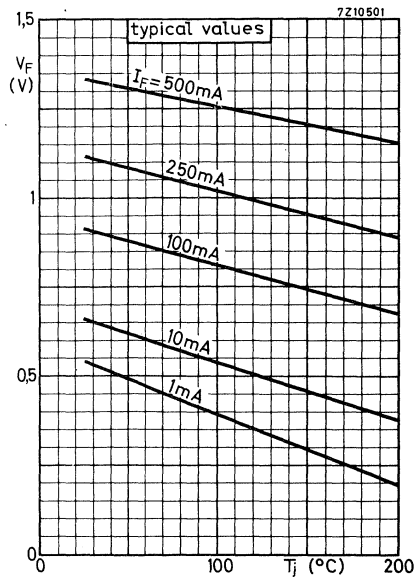
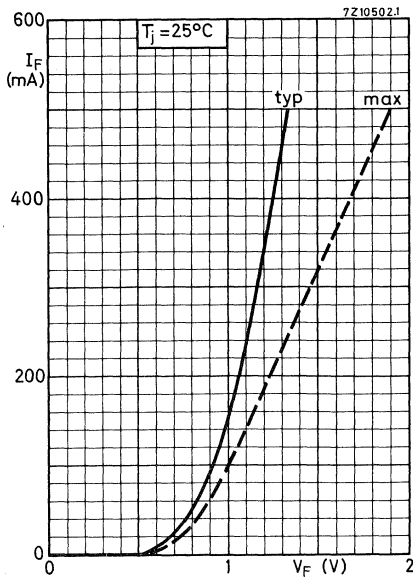
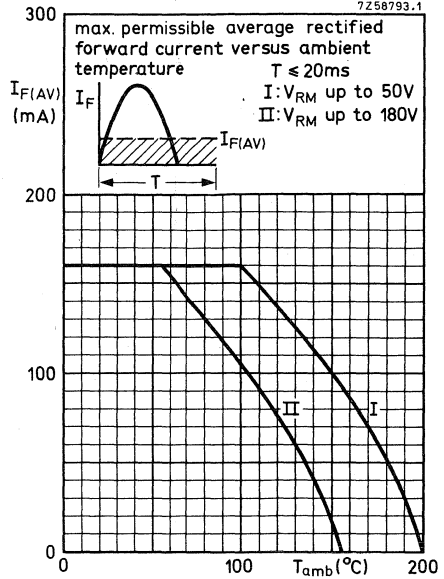
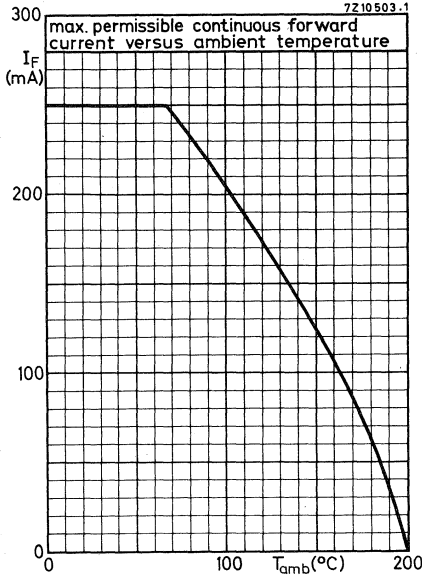

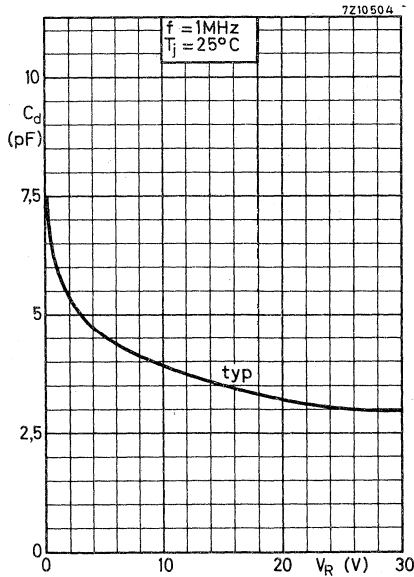
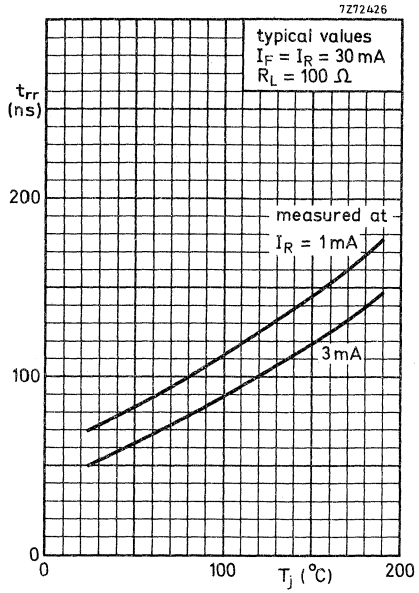
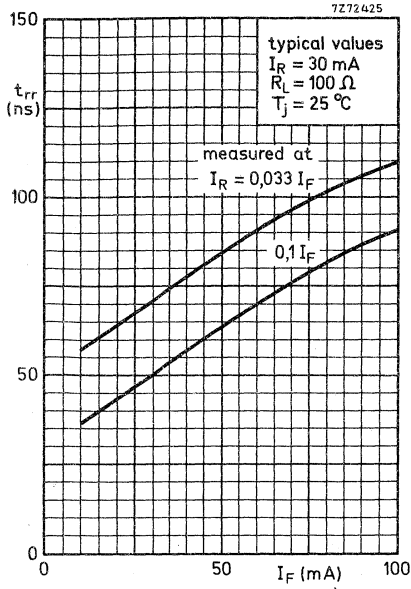

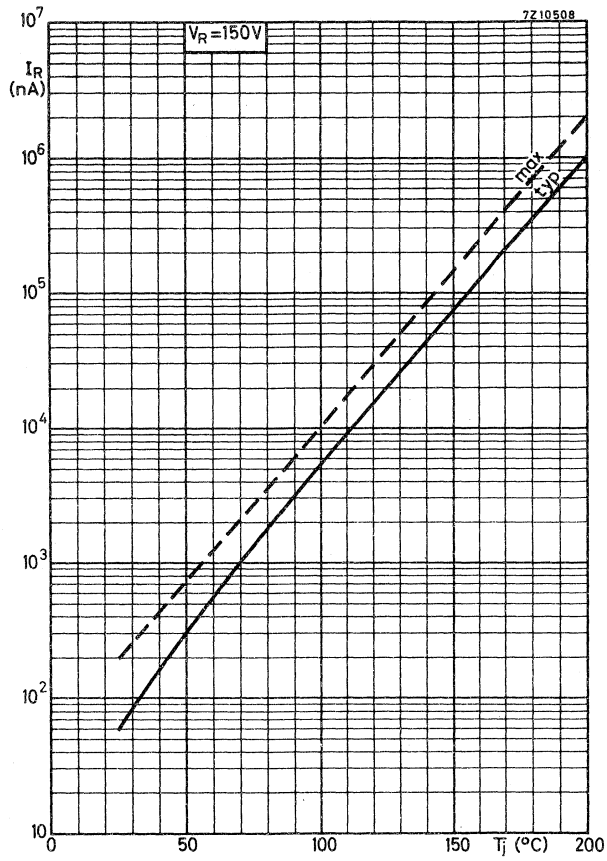

SILICON OXIDE PASSIVATED DIODE

Whiskerless diffused diode in a hard glass subminiature envelope.
 The BAX16 is primarily intended for general purpose industrial applications.

QUICK REFERENCE DATA			
Continuous reverse voltage	V_R	max.	150 V
Repetitive peak forward current	I_{FRM}	max.	300 mA
Thermal resistance from junction to ambient	$R_{th\ j-a}$	=	0,50 °C/mW
Forward voltage at $I_F = 100\text{ mA}$	V_F	<	1,3 V
Reverse recovery time when switched from $I_F = 30\text{ mA}$ to $I_R = 30\text{ mA}$; $R_L = 100\ \Omega$; measured at $I_R = 3\text{ mA}$	t_{rr}	<	120 ns
Recovery charge when switched from $I_F = 10\text{ mA}$ to $V_R = 5\text{ V}$; $R_L = 500\ \Omega$	Q_s	<	0,7 nC

MECHANICAL DATA

Dimensions in mm

SOD-17

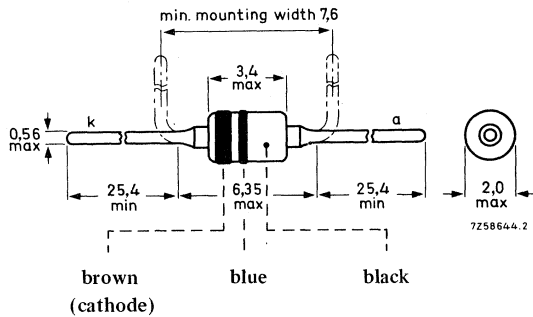

RATINGS Limiting values in accordance with the Absolute Maximum System (IEC 134)

Voltages

Continuous reverse voltage	V_R	max.	150	V
Repetitive peak reverse voltage	V_{RRM}	max.	150	V

Currents

Average rectified forward current (averaged over any 20 ms period)	$I_{F(AV)}$	max.	200	mA ¹⁾
Forward current (d. c.)	I_F	max.	200	mA
Repetitive peak forward current	I_{FRM}	max.	300	mA
Non-repetitive peak forward current				
$t = 1 \mu s$	I_{FSM}	max.	2500	mA
$t = 1 s$	I_{FSM}	max.	500	mA

Temperatures

Storage temperature	T_{stg}	-65 to +200	°C
Junction temperature	T_j	max. 200	°C

THERMAL RESISTANCE

From junction to ambient in free air	$R_{th j-a}$	=	0,50	°C/mW
--------------------------------------	--------------	---	------	-------

CHARACTERISTICS

$T_j = 25 \text{ °C}$ unless otherwise specified

Forward voltage

$I_F = 1 \text{ mA}$	V_F	<	0,65	V
$I_F = 10 \text{ mA}; T_j = 100 \text{ °C}$	V_F	<	0,85	V
$I_F = 100 \text{ mA}$	V_F	<	1,3	V ²⁾
$I_F = 200 \text{ mA}$	V_F	<	1,5	V ²⁾
$I_F = 200 \text{ mA}; T_j = 175 \text{ °C}$	V_F	<	1,4	V ²⁾

Reverse current

$V_R = 50 \text{ V}$	I_R	<	25	nA
$V_R = 50 \text{ V}; T_j = 150 \text{ °C}$	I_R	<	25	μA
$V_R = 150 \text{ V}$	I_R	<	100	nA
$V_R = 150 \text{ V}; T_j = 150 \text{ °C}$	I_R	<	100	μA

Diode capacitance (see also page 6)

$V_R = 0; f = 1 \text{ MHz}$	C_d	<	10	pF
------------------------------	-------	---	----	----

¹⁾ For sinusoidal operation see page 5. For pulse operation see page 4.

²⁾ Measured under pulse conditions to avoid excessive dissipation.

CHARACTERISTICS (continued)

$T_j = 25\text{ }^\circ\text{C}$

Reverse recovery time when switched from

$I_F = 30\text{ mA}$ to $I_R = 30\text{ mA}$; $R_L = 100\text{ }\Omega$;
measured at $I_R = 3\text{ mA}$ (see also page 6)

t_{rr} typ. 70 ns
< 120 ns

Test circuit and waveforms :

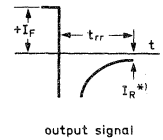
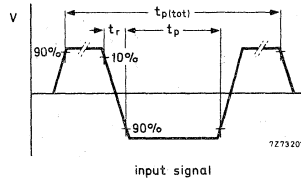
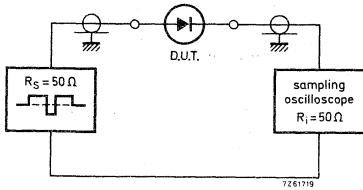

Input signal : Total pulse duration

$t_{p(tot)} = 10\text{ }\mu\text{s}$

*) $I_R = 3\text{ mA}$

Duty factor

$\delta = 0,0025$

Rise time of the reverse pulse

$t_r = 0,6\text{ ns}$

Reverse pulse duration

$t_p = 300\text{ ns}$

Oscilloscope: Rise time

$t_r = 0,35\text{ ns}$

Circuit capacitance $C \leq 1\text{ pF}$ ($C =$ oscilloscope input capacitance + parasitic capacitance)

Recovery charge when switched from

$I_F = 10\text{ mA}$ to $V_R = 5\text{ V}$; $R_L = 500\text{ }\Omega$

$Q_S < 0,7\text{ nC}$

Test circuit and waveform :

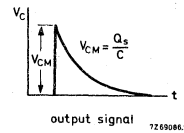
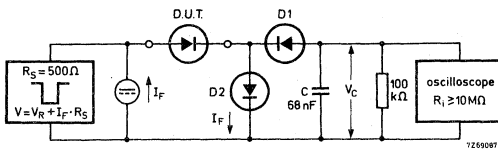

$D1 = D2 = \text{BAW62}$

Input signal: Rise time of the reverse pulse

$t_r = 15\text{ ns}$

Reverse pulse duration

$t_p = 35\text{ }\mu\text{s}$

Frequency

$f = 25\text{ kHz}$

Circuit capacitance $C \leq 30\text{ pF}$ ($C =$ oscilloscope input capacitance + parasitic capacitance)

7Z67945.1

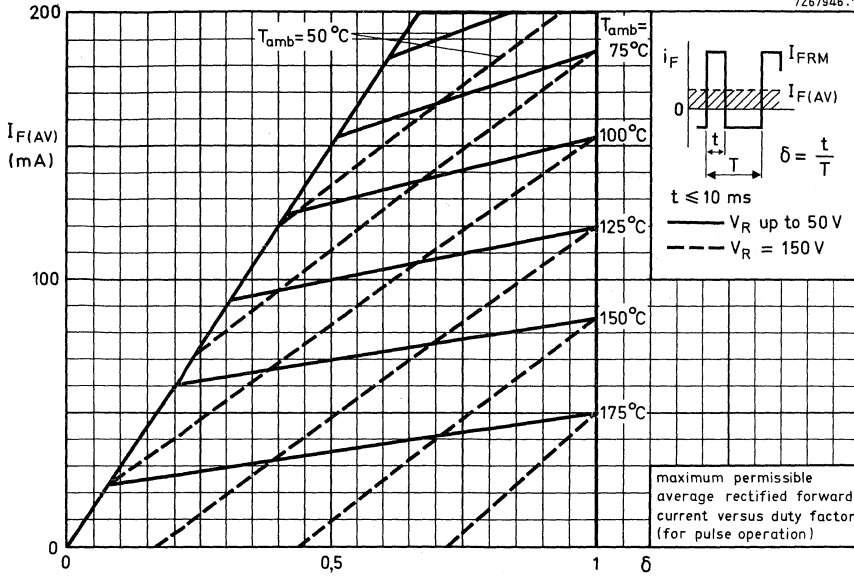

7Z67945.1

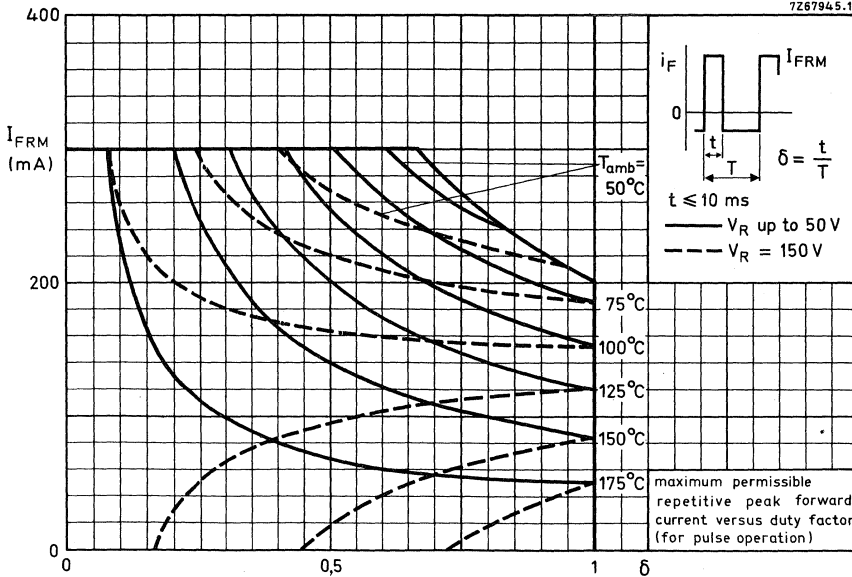

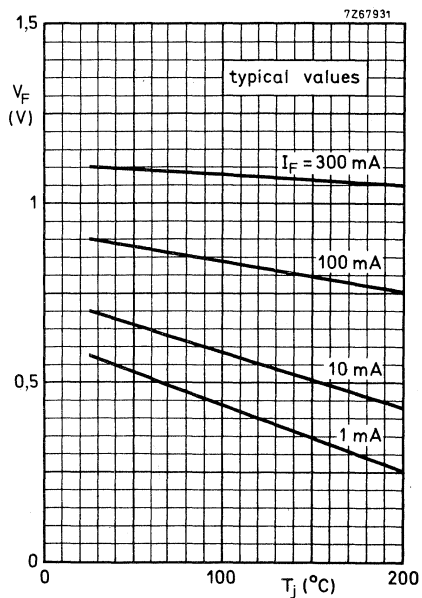
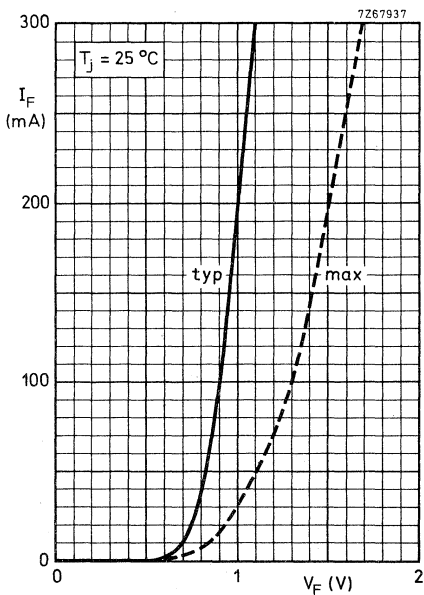
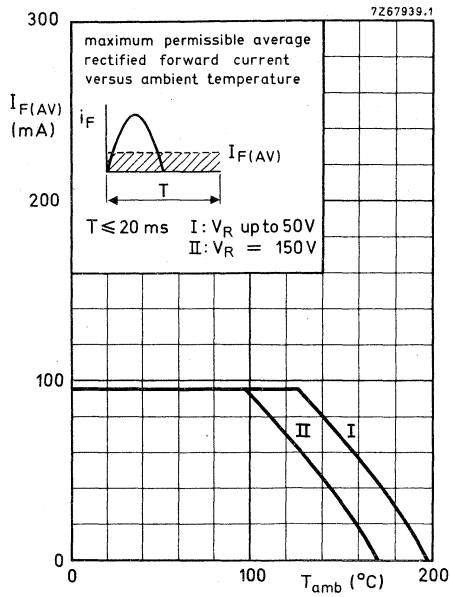
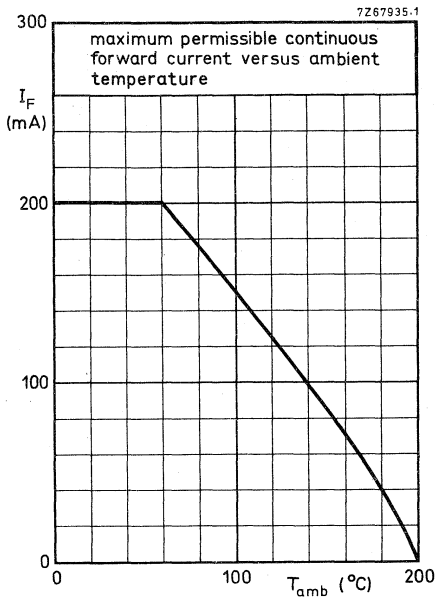

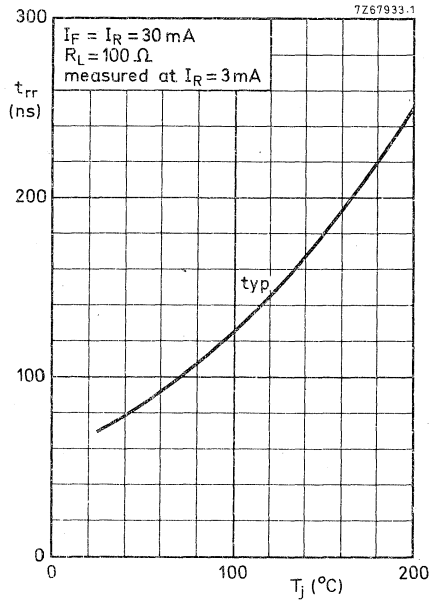
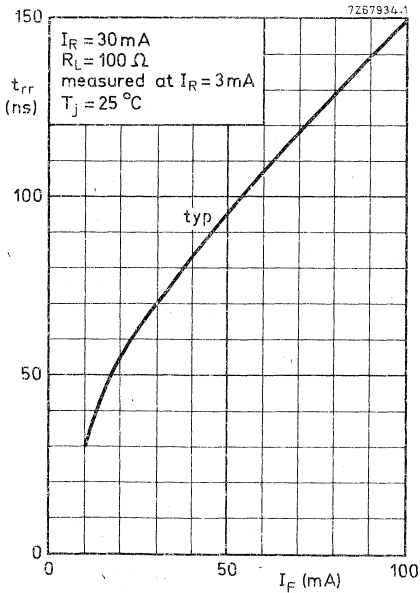
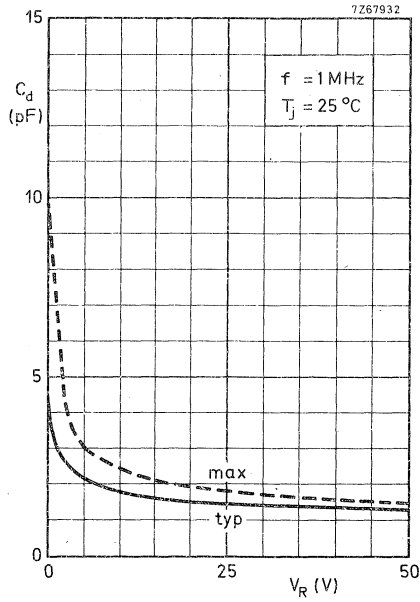

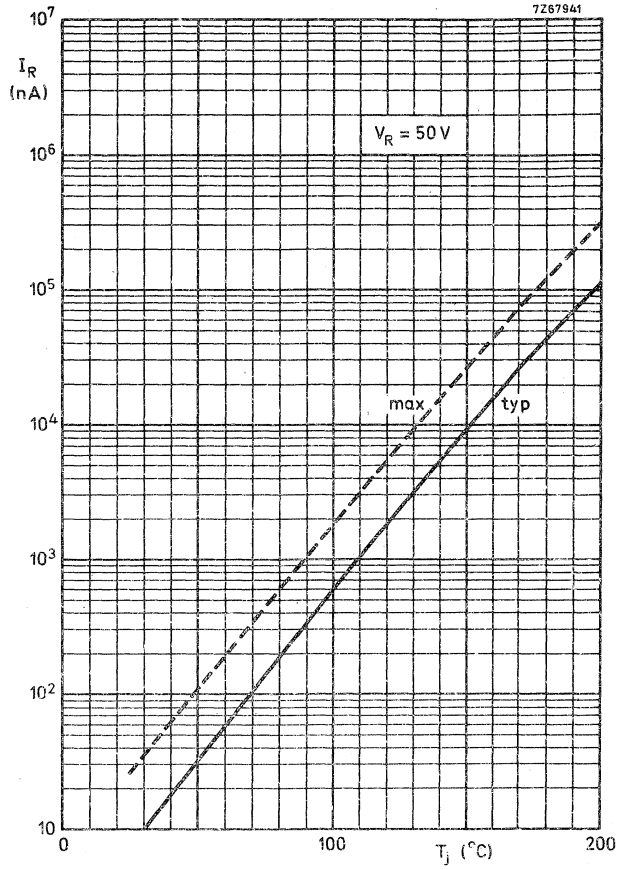

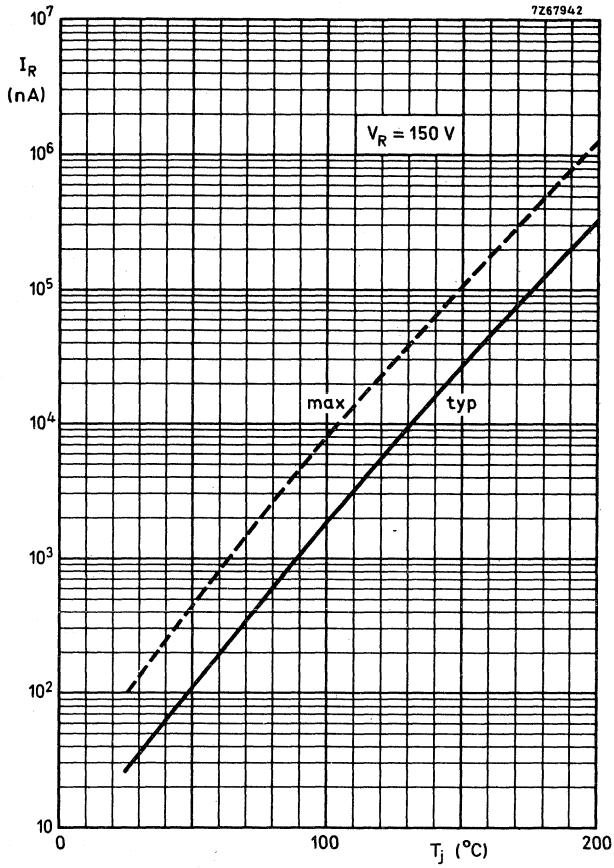

SILICON OXIDE PASSIVATED DIODE

Whiskerless diffused diode in a hard glass subminiature envelope.
 The BAX17 is primarily intended for general purpose industrial applications.

QUICK REFERENCE DATA			
Continuous reverse voltage	V_R	max.	200 V
Repetitive peak forward current	I_{FRM}	max.	300 mA
Thermal resistance from junction to ambient	$R_{th j-a}$	=	0,50 °C/mW
Forward voltage at $I_F = 200$ mA	V_F	<	1,2 V
Reverse recovery time when switched from $I_F = 30$ mA to $I_R = 30$ mA; $R_L = 100 \Omega$; measured at $I_R = 3$ mA	t_{rr}	<	120 ns
Recovery charge when switched from $I_F = 10$ mA to $V_R = 5$ V; $R_L = 500 \Omega$	Q_S	<	0,7 nC

MECHANICAL DATA

Dimensions in mm

SOD-17

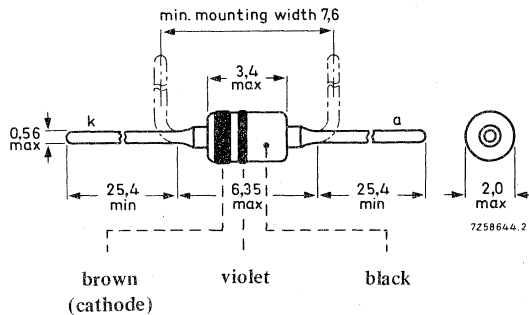

RATINGS Limiting values in accordance with the Absolute Maximum System (IEC 134)

Voltages

Continuous reverse voltage	V_R	max.	200	V
Repetitive peak reverse voltage	V_{RRM}	max.	200	V

Currents

Average rectified forward current (averaged over any 20 ms period)	$I_{F(AV)}$	max.	200	mA ¹⁾
Forward current (d. c.)	I_F	max.	200	mA
Repetitive peak forward current	I_{FRM}	max.	300	mA
Non-repetitive peak forward current t = 1 μ s	I_{FSM}	max.	2500	mA
t = 1 s	I_{FSM}	max.	500	mA

Temperatures

Storage temperature	T_{stg}	-65 to +200	$^{\circ}$ C
Junction temperature	T_j	max. 200	$^{\circ}$ C

THERMAL RESISTANCE

From junction to ambient in free air	$R_{th\ j-a}$	=	0,50	$^{\circ}$ C/mW
--------------------------------------	---------------	---	------	-----------------

CHARACTERISTICS

$T_j = 25\ ^{\circ}$ C unless otherwise specified

Forward voltages

$I_F = 1\ \text{mA}$	V_F	<	0,65	V
$I_F = 10\ \text{mA}; T_j = 100\ ^{\circ}\text{C}$	V_F	<	0,75	V
$I_F = 100\ \text{mA}$	V_F	<	1,1	V ²⁾
$I_F = 200\ \text{mA}$	V_F	<	1,2	V ²⁾
$I_F = 200\ \text{mA}; T_j = 175\ ^{\circ}\text{C}$	V_F	<	1,2	V ²⁾

Reverse currents

$V_R = 50\ \text{V}$	I_R	<	25	nA
$V_R = 50\ \text{V}; T_j = 150\ ^{\circ}\text{C}$	I_R	<	25	μ A
$V_R = 150\ \text{V}$	I_R	<	100	nA
$V_R = 200\ \text{V}; T_j = 150\ ^{\circ}\text{C}$	I_R	<	100	μ A

Diode capacitance (see also page 6)

$V_R = 0; f = 1\ \text{MHz}$	C_d	<	10	pF
------------------------------	-------	---	----	----

¹⁾ For sinusoidal operation see page 5. For pulse operation see page 4.

²⁾ Measured under pulse conditions to avoid excessive dissipation.

CHARACTERISTICS (continued)

$T_j = 25 \text{ }^\circ\text{C}$

Reverse recovery time when switched from

$I_F = 30 \text{ mA}$ to $I_R = 30 \text{ mA}$; $R_L = 100 \text{ } \Omega$;

measured at $I_R = 3 \text{ mA}$ (see also page 6)

t_{rr} typ. 70 ns
 < 120 ns

Test circuit and waveforms :

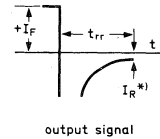
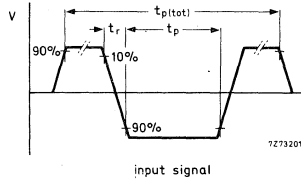
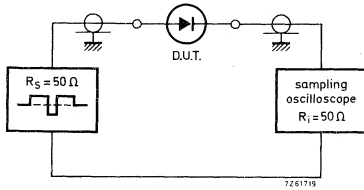

Input signal : Total pulse duration

$t_p(\text{tot}) = 10 \text{ } \mu\text{s}$

*) $I_R = 3 \text{ mA}$

Duty factor

$\delta = 0,0025$

Rise time of the reverse pulse

$t_r = 0,6 \text{ ns}$

Reverse pulse duration

$t_p = 300 \text{ ns}$

Oscilloscope: Rise time

$t_r = 0,35 \text{ ns}$

Circuit capacitance $C \leq 1 \text{ pF}$ ($C = \text{oscilloscope input capacitance} + \text{parasitic capacitance}$)

Recovery charge when switched from

$I_F = 10 \text{ mA}$ to $V_R = 5 \text{ V}$; $R_L = 500 \text{ } \Omega$

$Q_S < 0,7 \text{ nC}$

Test circuit and waveform:

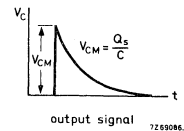
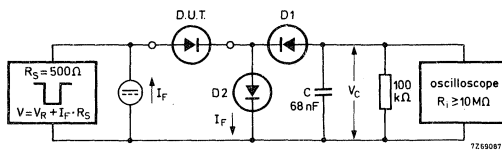

$D1 = D2 = \text{BAW62}$

Input signal: Rise time of the reverse pulse

$t_r = 15 \text{ ns}$

Reverse pulse duration

$t_p = 35 \text{ } \mu\text{s}$

Frequency

$f = 25 \text{ kHz}$

Circuit capacitance $C \leq 30 \text{ pF}$ ($C = \text{oscilloscope input capacitance} + \text{parasitic capacitance}$)

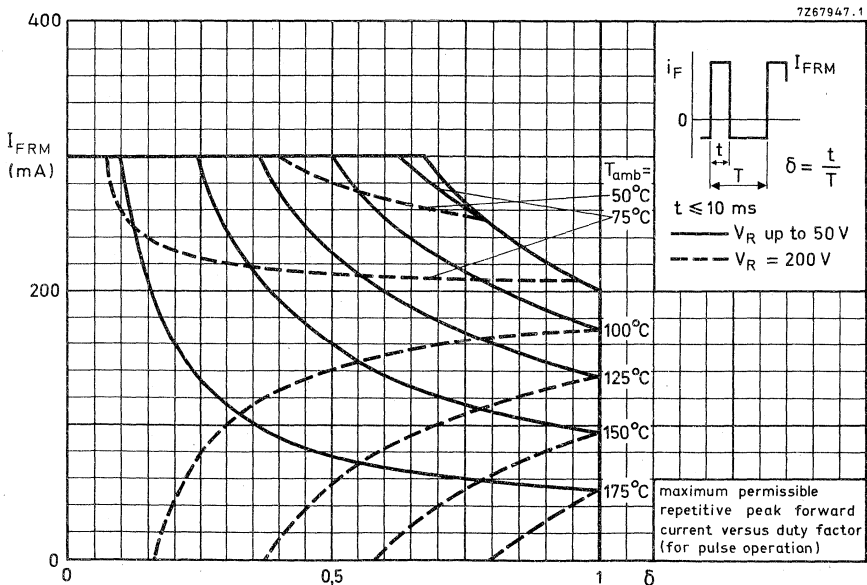
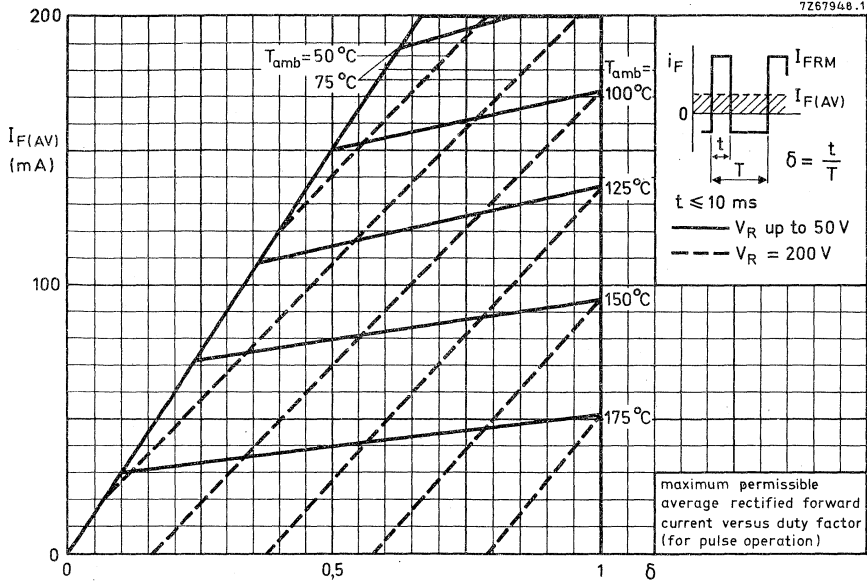

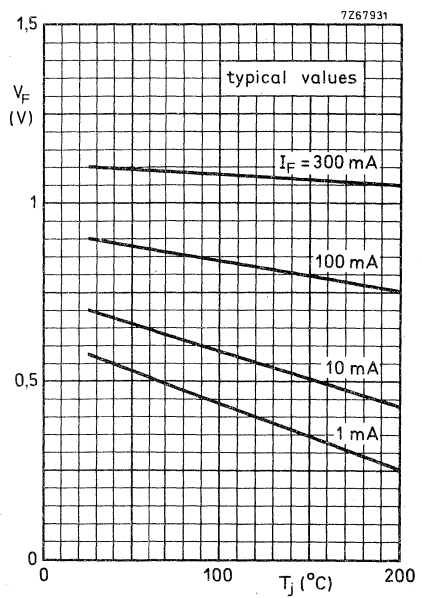
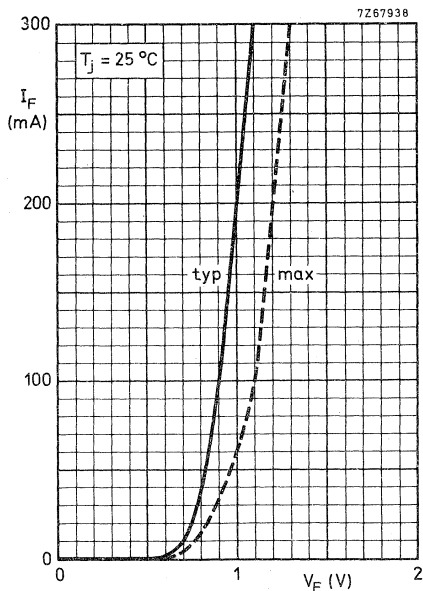
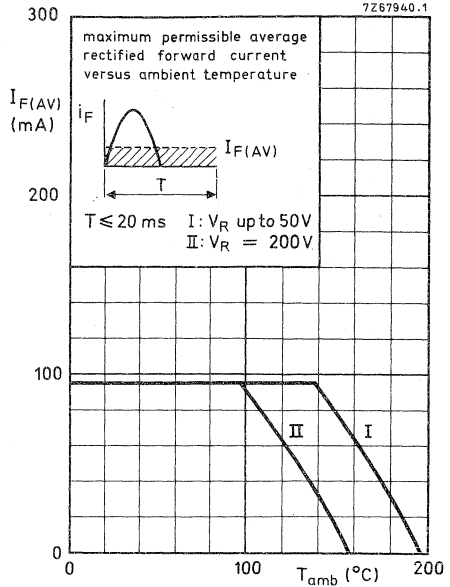
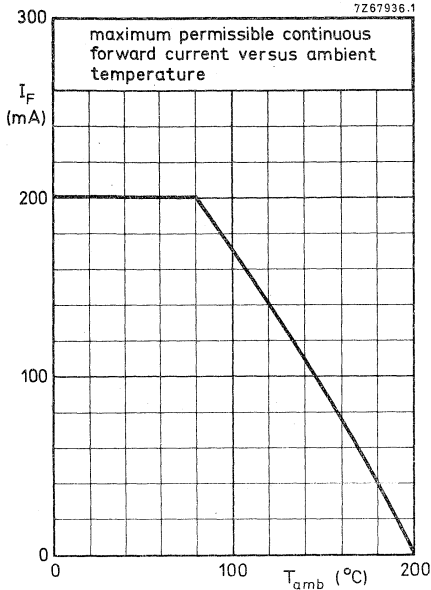

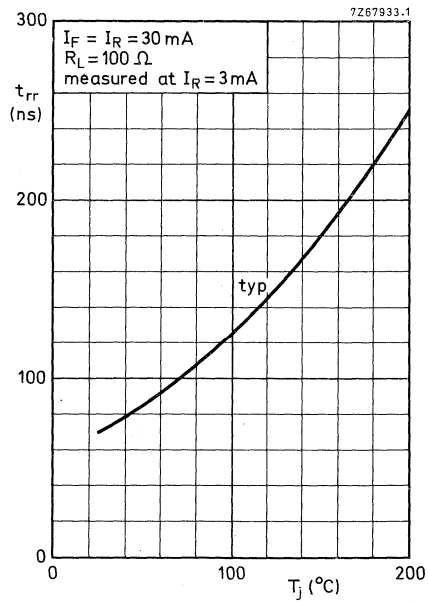
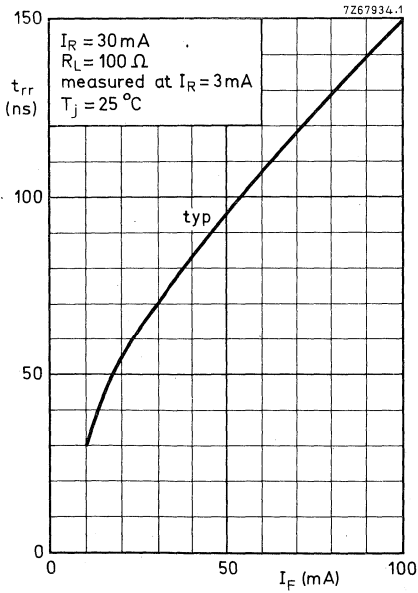
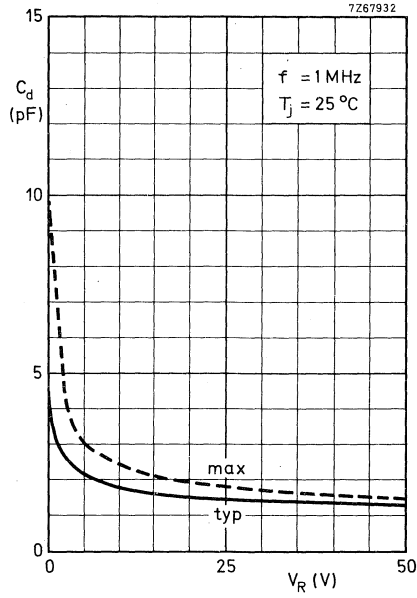

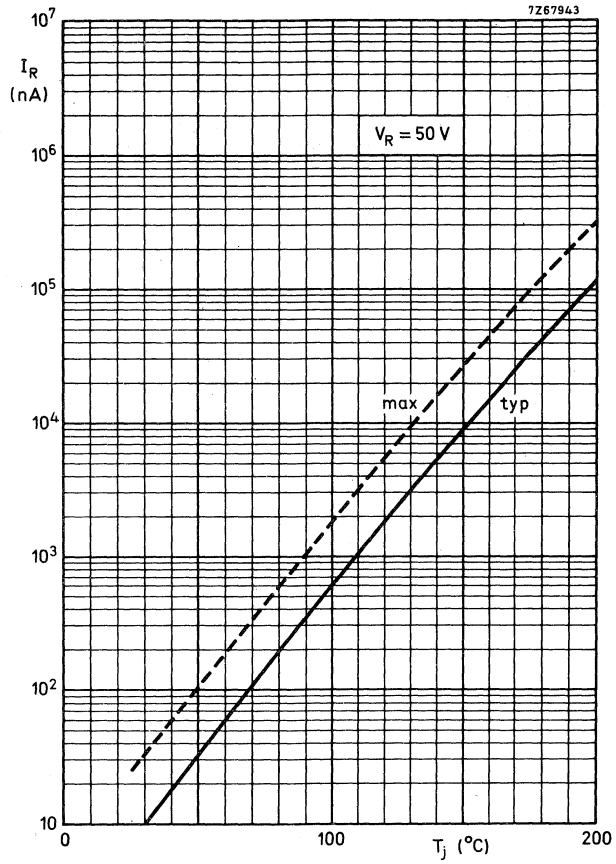

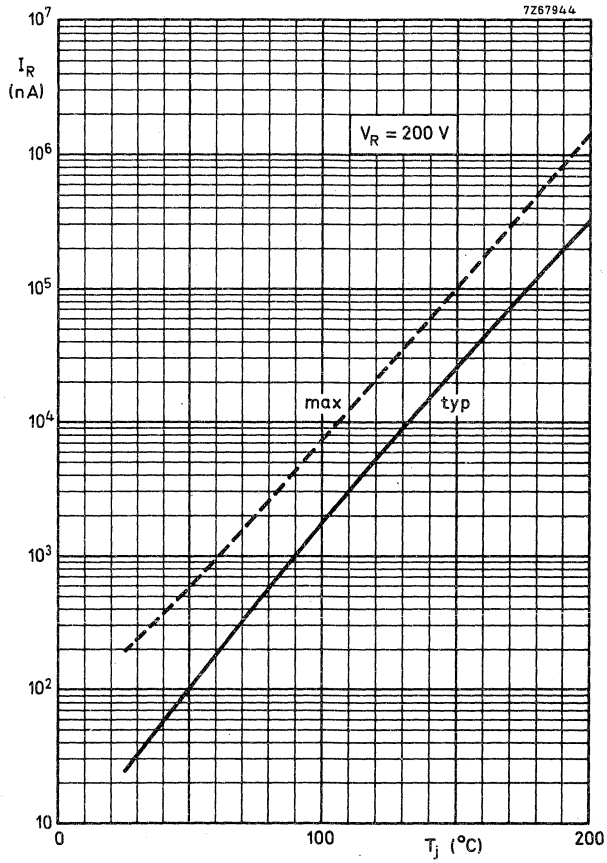

SILICON OXIDE PASSIVATED DIODE

Whiskerless diffused diode in a hard glass subminiature envelope.
It is a general purpose diode primarily intended for rectifier applications.

QUICK REFERENCE DATA				
Repetitive peak reverse voltage	V_{RRM}	max.	75	V
Average forward current	$I_{F(AV)}$	max.	350	mA
Non-repetitive peak forward current	I_{FSM}	max.	6,0	A

MECHANICAL DATA

Dimensions in mm

SOD-17

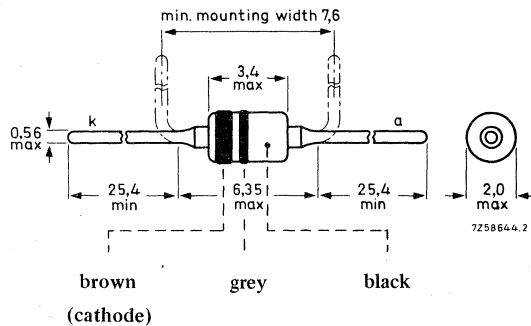

RATINGS Limiting values in accordance with the Absolute Maximum System (IEC134)

Voltages

Repetitive peak reverse voltage	V_{RRM}	max.	75	V
Continuous reverse voltage	V_R	max.	75	V

Currents

Forward current (d. c.)	I_F	max.	500	mA
Average forward current (averaged over any 20 ms period; see also page 3)	$I_{F(AV)}$	max.	350	mA
Repetitive peak forward current	I_{FRM}	max.	2,0	A
Non-repetitive peak forward current ($t = 10$ ms; half sine wave) $T_j = 25$ °C prior to surge	I_{FSM}	max.	6,0	A

Temperatures

Storage temperature	T_{stg}	-65 to +200	°C
Junction temperature	T_j	max. 200	°C

THERMAL RESISTANCE

From junction to ambient in free air at maximum lead length	$R_{th\ j-a}$	=	0,3	°C/mW
--	---------------	---	-----	-------

CHARACTERISTICS

Forward voltage

$I_F = 2$ A; $T_j = 150$ °C	V_F	<	2,0	V
-----------------------------	-------	---	-----	---

Reverse current

$V_R = 75$ V; $T_j = 150$ °C	I_R	<	100	µA
------------------------------	-------	---	-----	----

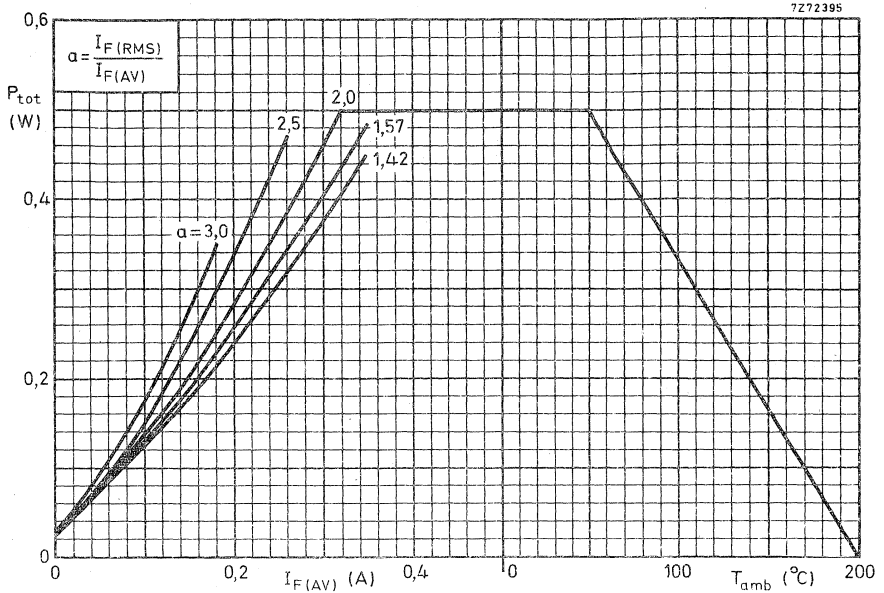

From the left-hand graph the total power dissipation can be found as a function of the average output current.

The parameter $\alpha = \frac{I_{F(RMS)} \text{ per diode}}{I_{F(AV)} \text{ per diode}}$ depends on $n\omega R_L C_L$ and $\frac{R_t + r_{diff}}{nR_L}$ and can be found from existing graphs.

See Application Book: RECTIFIER DIODES.

Once the power dissipation is known, the max. permissible ambient temperature follows from the right-hand graph.

For the series resistance, added to limit the initial peak rectifier current, the required minimum value can be found from the upper graph on page 4.

The value of r_{diff} can be found from the left-hand graph on page 5.

7Z72393

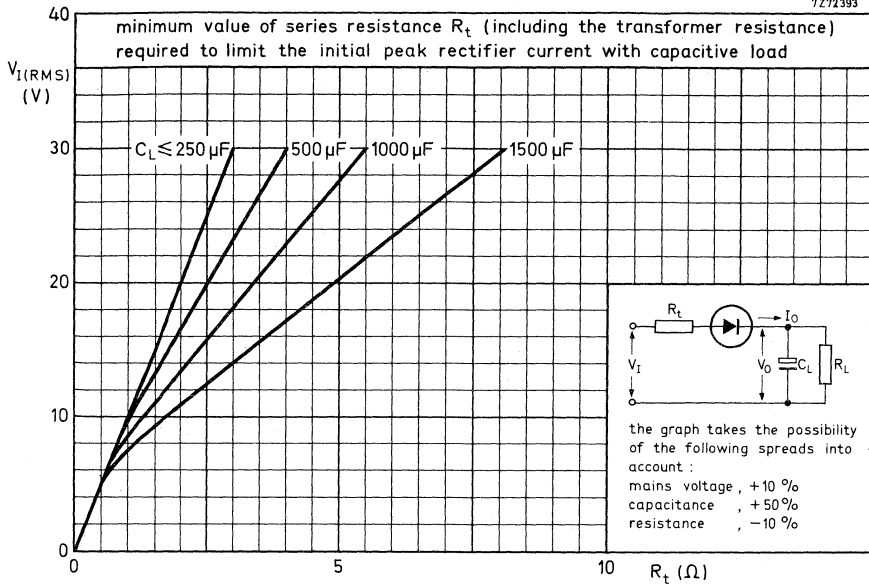

7Z72399

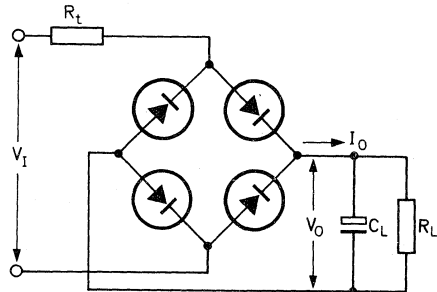
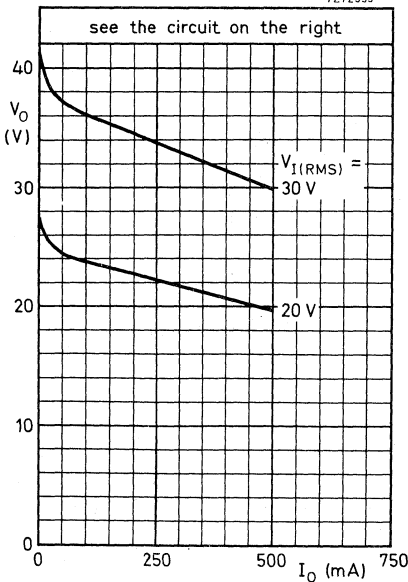

V_I (V)	R_t (Ω)	C_L (μF)
30	5, 6	1000
20	3, 4	1000

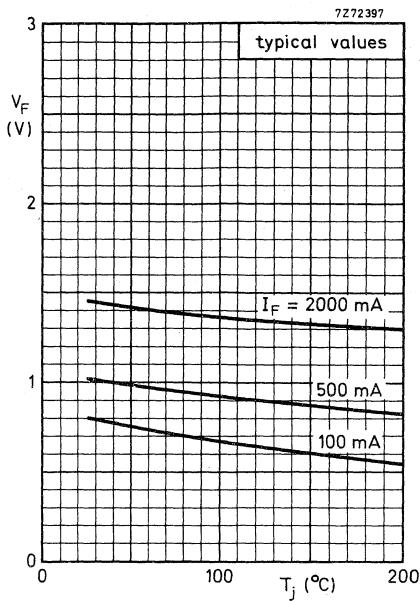
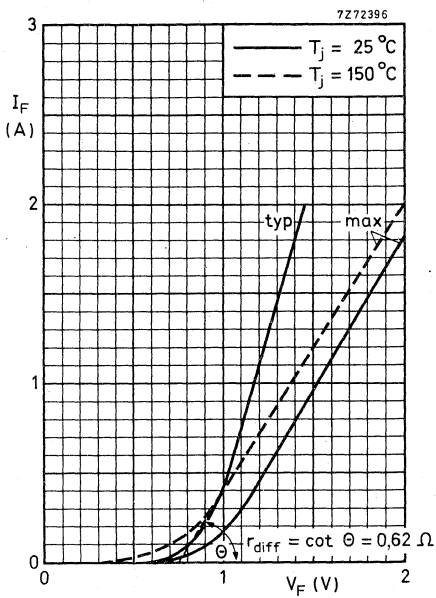

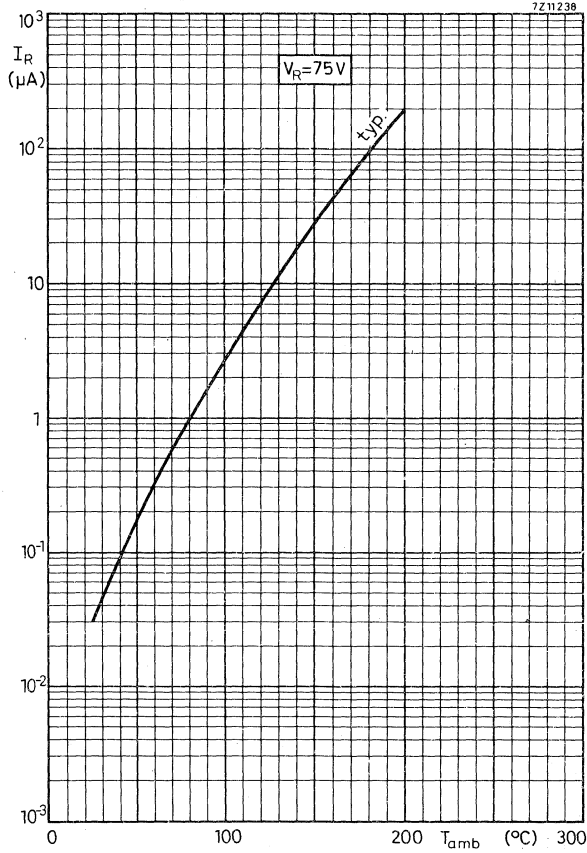

SILICON OXIDE PASSIVATED DIODES

Whiskerless diodes in hard glass subminiature envelopes.
These high-speed diodes are primarily intended for fast logic applications.

QUICK REFERENCE DATA			
Continuous reverse voltage	V_R	max.	75 V
Repetitive peak reverse voltage	V_{RRM}	max.	100 V
Repetitive peak forward current	I_{FRM}	max.	225 mA
Forward voltage	V_F	<	1 V
<u>1N914</u> : $I_F = 10$ mA			
<u>1N914A</u> : $I_F = 20$ mA			
Reverse recovery time when switched from $I_F = 10$ mA to $I_R = 60$ mA; $R_L = 100 \Omega$; measured at $I_R = 1$ mA	t_{rr}	<	4 ns

MECHANICAL DATA

Dimensions in mm

SOD-17

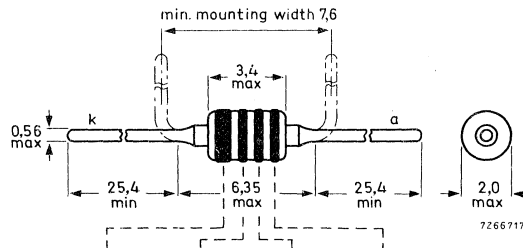

1N914 :	white	brown	yellow	not coloured
1N914A:	white	brown	yellow	brown

(cathode)

1N914 1N914A

RATINGS Limiting values in accordance with the Absolute Maximum System (IEC 134)

Voltages

Continuous reverse voltage	V_R	max.	75	V
Repetitive peak reverse voltage	V_{RRM}	max.	100	V

Currents

Average rectified forward current (averaged over any 20 ms period)	$T_{amb} = 25\text{ }^\circ\text{C}$	$I_{F(AV)}$	max.	75	mA
	$T_{amb} = 150\text{ }^\circ\text{C}$	$I_{F(AV)}$	max.	10	mA
Forward current (d. c.)		I_F	max.	75	mA
Repetitive peak forward current		I_{FRM}	max.	225	mA
Non-repetitive peak forward current (t = 1 s)		I_{FSM}	max.	500	mA
Total power dissipation		P_{tot}	max.	250	mW

Temperatures

Storage temperature	T_{stg}	-65 to +200	$^\circ\text{C}$
Operating ambient temperature	T_{amb}	-65 to +175	$^\circ\text{C}$

CHARACTERISTICS

$T_j = 25\text{ }^\circ\text{C}$ unless otherwise specified

Forward voltages

<u>1N914</u> : $I_F = 10\text{ mA}$	}	V_F	<	1	V
<u>1N914A</u> : $I_F = 20\text{ mA}$					

Reverse avalanche breakdown voltage

$I_R = 100\text{ }\mu\text{A}$	$V_{(BR)R}$	>	100	V
--------------------------------	-------------	---	-----	---

Reverse currents

$V_R = 20\text{ V}$	I_R	<	25	nA
$V_R = 75\text{ V}$	I_R	<	5	μA
$V_R = 20\text{ V}; T_j = 150\text{ }^\circ\text{C}$	I_R	<	50	μA

Diode capacitance

$V_R = 0; f = 1\text{ MHz}$	C_d	<	4	pF
-----------------------------	-------	---	---	----

CHARACTERISTICS (continued)

$T_j = 25\text{ }^\circ\text{C}$

Forward recovery voltage when switched to

$I_F = 50\text{ mA}; t_r = 30\text{ ns}$

$V_{fr} < 2,5\text{ V}$

Test circuit and waveforms :

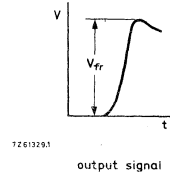
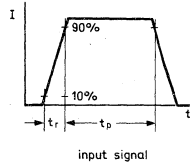
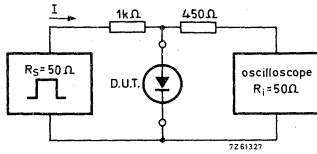

Input signal : Rise time of the forward pulse

$t_r = 20\text{ ns}$

Forward current pulse duration

$t_p = 120\text{ ns}$

Duty factor

$\delta = 0,01$

Oscilloscope : Rise time

$t_r = 0,35\text{ ns}$

Circuit capacitance $C \leq 1\text{ pF}$ ($C =$ oscilloscope input capacitance + parasitic capacitance)

Reverse recovery time when switched from

$I_F = 10\text{ mA to } I_R = 10\text{ mA}; R_L = 100\ \Omega;$ measured at $I_R = 1\text{ mA}$

$t_{rr} < 8\text{ ns}$

$I_F = 10\text{ mA to } I_R = 60\text{ mA}; R_L = 100\ \Omega;$ measured at $I_R = 1\text{ mA}$

$t_{rr} < 4\text{ ns}$

Test circuit and waveforms :

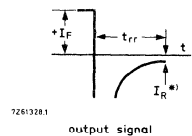
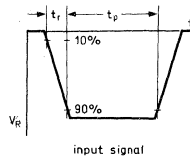
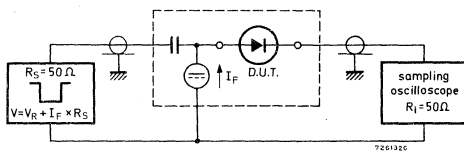

Input signal : Rise time of the reverse pulse

$t_r = 0,6\text{ ns}$

*) $I_R = 1\text{ mA}$

Reverse pulse duration

$t_p = 100\text{ ns}$

Duty factor

$\delta = 0,05$

Oscilloscope : Rise time

$t_r = 0,35\text{ ns}$

Circuit capacitance $C \leq 1\text{ pF}$ ($C =$ oscilloscope input capacitance + parasitic capacitance)

CHARACTERISTICS (continued)

$T_j = 25\text{ }^\circ\text{C}$

Rectifying efficiency

$$\eta = \frac{V_O}{V_{i(\text{rms})} \sqrt{2}}$$

$f = 100\text{ MHz}; V_{i(\text{rms})} = 2\text{ V}$

$\eta > 45\%$

Test circuit:

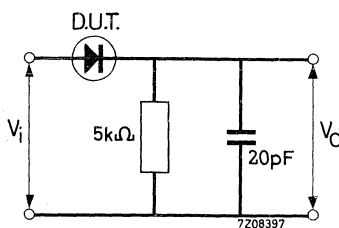

SILICON OXIDE PASSIVATED DIODES

Whiskerless diodes in hard glass subminiature envelopes.
These high-speed diodes are primarily intended for fast logic applications.

QUICK REFERENCE DATA			
Continuous reverse voltage	V_R	max.	75 V
Repetitive peak reverse voltage	V_{RRM}	max.	100 V
Repetitive peak forward current	I_{FRM}	max.	225 mA
Forward voltage			
<u>1N916</u> : $I_F = 10$ mA	V_F	<	1 V
<u>1N916A</u> : $I_F = 20$ mA			
<u>1N916B</u> : $I_F = 30$ mA			
Reverse recovery time when switched from $I_F = 10$ mA to $I_R = 60$ mA; $R_L = 100 \Omega$; measured at $I_R = 1$ mA			
	t_{rr}	<	4 ns

MECHANICAL DATA

Dimensions in mm

SOD-17

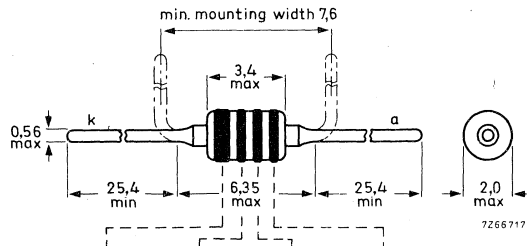

1N916 :	white	brown	blue	not coloured
1N916A:	white	brown	blue	brown
1N916B:	white	brown	blue	red

(cathode)

RATINGS Limiting values in accordance with the Absolute Maximum System (IEC 134)

Voltages

Continuous reverse voltage	V_R	max.	75	V
Repetitive peak reverse voltage	V_{RRM}	max.	100	V

Currents

Average rectified forward current (averaged over any 20 ms period)	$T_{amb} = 25\text{ }^\circ\text{C}$	$I_{F(AV)}$	max.	75	mA
	$T_{amb} = 150\text{ }^\circ\text{C}$	$I_{F(AV)}$	max.	10	mA
Forward current (d. c.)		I_F	max.	75	mA
Repetitive peak forward current		I_{FRM}	max.	225	mA
Non-repetitive peak forward current (t = 1 s)		I_{FSM}	max.	500	mA
Total power dissipation		P_{tot}	max.	250	mW

Temperatures

Storage temperature	T_{stg}	-65 to +200	$^\circ\text{C}$
Operating ambient temperature	T_{amb}	-65 to +175	$^\circ\text{C}$

CHARACTERISTICS

$T_j = 25\text{ }^\circ\text{C}$ unless otherwise specified

Forward voltages

$1N916 : I_F = 10\text{ mA}$	}	V_F	<	1	V
$1N916A : I_F = 20\text{ mA}$					
$1N916B : I_F = 30\text{ mA}$					
$1N916B : I_F = 5\text{ mA}$		V_F		0,63 to 0,73	V

Reverse avalanche breakdown voltage

$I_R = 100\text{ }\mu\text{A}$	$V_{(BR)R}$	>	100	V
--------------------------------	-------------	---	-----	---

Reverse currents

$V_R = 20\text{ V}$	I_R	<	25	nA
$V_R = 75\text{ V}$	I_R	<	5	μA
$V_R = 20\text{ V}; T_j = 150\text{ }^\circ\text{C}$	I_R	<	50	μA

Diode capacitance

$V_R = 0; f = 1\text{ MHz}$	C_d	<	2	pF
-----------------------------	-------	---	---	----

CHARACTERISTICS (continued)

$T_j = 25\text{ }^\circ\text{C}$

Forward recovery voltage when switched to

$I_F = 50\text{ mA}; t_r = 20\text{ ns}$

$V_{fr} < 2,5\text{ V}$

Test circuit and waveforms :

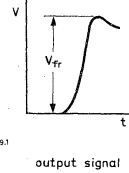
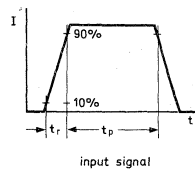
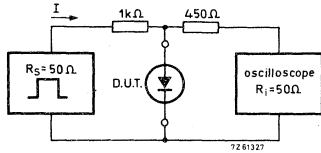

Input signal : Rise time of the forward pulse

$t_r = 20\text{ ns}$

Forward current pulse duration

$t_p = 120\text{ ns}$

Duty factor

$\delta = 0,01$

Oscilloscope : Rise time

$t_r = 0,35\text{ ns}$

Circuit capacitance $C \leq 1\text{ pF}$ ($C =$ oscilloscope input capacitance + parasitic capacitance)

Reverse recovery time when switched from

$I_F = 10\text{ mA}$ to $I_R = 60\text{ mA}; R_L = 100\text{ }\Omega$;

measured at $I_R = 1\text{ mA}$

$t_{rr} < 4\text{ ns}$

Test circuit and waveforms :

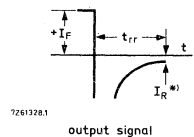
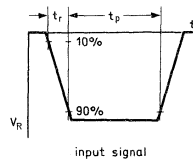
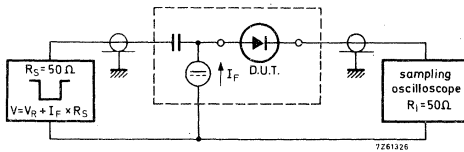

Input signal : Rise time of the reverse pulse

$t_r = 0,6\text{ ns}$

*) $I_R = 1\text{ mA}$

Reverse pulse duration

$t_p = 100\text{ ns}$

Duty factor

$\delta = 0,05$

Oscilloscope : Rise time

$t_r = 0,35\text{ ns}$

Circuit capacitance $C \leq 1\text{ pF}$ ($C =$ oscilloscope input capacitance + parasitic capacitance)

CHARACTERISTICS (continued)

$T_j = 25\text{ }^\circ\text{C}$

Rectifying efficiency

$$\eta = \frac{V_O}{V_{i(\text{rms})} \sqrt{2}}$$

$f = 100\text{ MHz}; V_{i(\text{rms})} = 2\text{ V}$

$\eta > 45\%$

Test circuit:

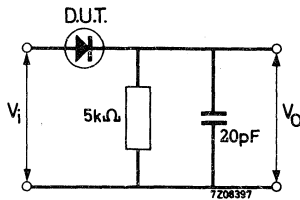

ULTRA HIGH-SPEED SILICON DIODE

General purpose diode for military and industrial applications.

RATINGS Limiting values in accordance with the Absolute Maximum System (IEC 134)

Voltage

Continuous reverse voltage at $T_{amb} = 25\text{ }^{\circ}\text{C}$ V_R max. 25 V

Power dissipation

Total power dissipation at $T_{amb} = 25\text{ }^{\circ}\text{C}$ P_{tot} max. 250 mW

Temperature

Storage temperature T_{stg} -65 to +200 $^{\circ}\text{C}$

THERMAL RESISTANCE

From junction to ambient in free air $R_{th\ j-a} = 0,6\text{ }^{\circ}\text{C/mW}$

CHARACTERISTICS

$T_j = 25\text{ }^{\circ}\text{C}$ unless otherwise specified

Forward voltage

$I_F = 30\text{ mA}$ $V_F < 1\text{ V}$

Reverse avalanche breakdown voltage

$I_R = 5\text{ }\mu\text{A}$ $V_{(BR)R} > 35\text{ V}$

Reverse currents

$V_R = 25\text{ V}$ $I_R < 0,1\text{ }\mu\text{A}$

$V_R = 25\text{ V}; T_{amb} = 150\text{ }^{\circ}\text{C}$ $I_R < 100\text{ }\mu\text{A}$

Diode capacitance

$V_R = 0; f = 1\text{ MHz}$ $C_d < 4\text{ pF}$

MECHANICAL DATA

Dimensions in mm

DO-35

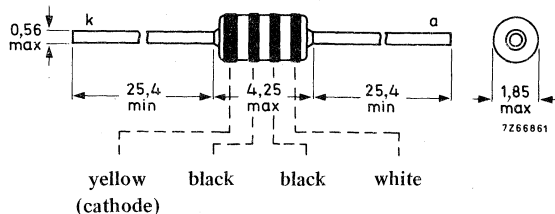

CHARACTERISTICS (continued)

$T_j = 25\text{ }^\circ\text{C}$

→ Reverse recovery time when switched from

$I_F = 10\text{ mA}$ to $I_R = 10\text{ mA}$; $R_L = 100\text{ }\Omega$; measured at $I_R = 1\text{ mA}$

$t_{rr} < 4\text{ ns}$

$I_F = 10\text{ mA}$ to $I_R = 60\text{ mA}$; $R_L = 100\text{ }\Omega$; measured at $I_R = 1\text{ mA}$

$t_{rr} < 2\text{ ns}$

Test circuit and waveforms :

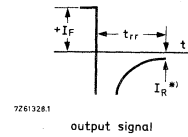
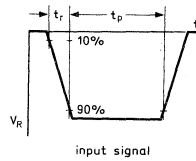
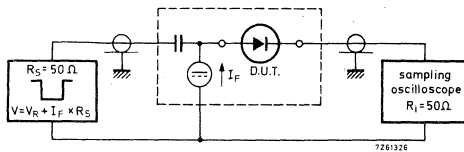

Input signal : Rise time of the reverse pulse

$t_r \leq 0,5\text{ ns}$

*) $I_R = 1\text{ mA}$

Reverse pulse duration

$t_p = 100\text{ ns}$

Duty factor

$\delta = 0,05$

Oscilloscope : Rise time

$t_r = 0,35\text{ ns}$

Circuit capacitance $C \leq 1\text{ pF}$ ($C =$ oscilloscope input capacitance + parasitic capacitance)

1N4148
1N4446
1N4448

ULTRA-HIGH-SPEED SILICON DIODES

Whiskerless diodes in subminiature DO-35 envelopes.
These diodes are primarily intended for fast logic applications.

QUICK REFERENCE DATA			
Continuous reverse voltage	V_R	max.	75 V
Repetitive peak reverse voltage	V_{RRM}	max.	75 V
Repetitive peak forward current	I_{FRM}	max.	225 mA
	I_{FRM}	max.	450 mA
Forward voltage			
<u>1N4148</u> : $I_F = 10$ mA	V_F	<	1 V
<u>1N4446</u> : $I_F = 20$ mA			
<u>1N4448</u> : $I_F = 100$ mA			
Reverse recovery time when switched from $I_F = 10$ mA to $I_R = 60$ mA; $R_L = 100 \Omega$; measured at $I_R = 1$ mA	t_{rr}	<	4 ns

MECHANICAL DATA

Dimensions in mm

DO-35

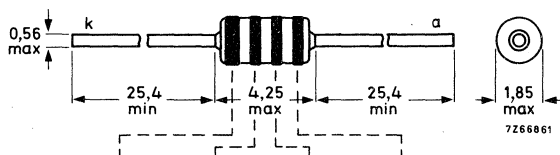

1N4148:	yellow	brown	yellow	grey
1N4446:	yellow	yellow	yellow	blue
1N4448:	yellow	yellow	yellow	grey

(cathode)

IN4148
IN4446
IN4448

RATINGS Limiting values in accordance with the Absolute Maximum System (IEC 134)

<u>Voltages</u>			IN4148		IN4446 IN4448	
Continuous reverse voltage	V_R	max.	75		75	V
Repetitive peak reverse voltage	V_{RRM}	max.	75		75	V
<u>Currents</u>						
Average rectified forward current	$I_F(AV)$	max.	75		150	mA
Forward current (d. c.)	I_F	max.	75		200	mA
Repetitive peak forward current	I_{FRM}	max.	225		450	mA
Non-repetitive peak forward current	I_{FSM}	max.	2000		2000	mA
			$t = 1 \mu s$			
			$t = 1 s$		500	mA
<u>Total power dissipation up to $T_{amb} = 25^\circ C$</u>	P_{tot}	max.	500		mW	
<u>Derating factor</u>			2, 85		mW/ $^\circ C$	

Temperatures

Storage temperature	T_{stg}		-65 to +200		$^\circ C$	
Junction temperature	T_j	max.	200		$^\circ C$	

CHARACTERISTICS

$T_j = 25^\circ C$ unless otherwise specified

Forward voltages

$I_F = 10 \text{ mA}$	}	V_F	<	1	V
$I_F = 20 \text{ mA}$					
$I_F = 100 \text{ mA}$					
$I_F = 5 \text{ mA}$		V_F		0, 62 to 0, 72	V

Reverse avalanche breakdown voltage

$I_R = 100 \mu A$	$V_{(BR)R}$	>	100	V
$I_R = 5 \mu A$	$V_{(BR)R}$	>	75	V

Reverse currents

$V_R = 20 \text{ V}$	I_R	<	25	nA
$V_R = 20 \text{ V}; T_j = 100^\circ C$	<u>IN4448</u> I_R	<	3	μA
$V_R = 20 \text{ V}; T_j = 150^\circ C$	I_R	<	50	μA

Diode capacitance

$V_R = 0; f = 1 \text{ MHz}$	C_d	<	4	pF
------------------------------	-------	---	---	----

CHARACTERISTICS (continued)

$T_j = 25\text{ }^\circ\text{C}$

Forward recovery voltage when switched to

$I_F = 50\text{ mA}; t_r = 20\text{ ns}$

$V_{fr} < 2,5\text{ V}$

Test circuit and waveforms:

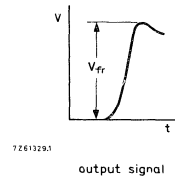
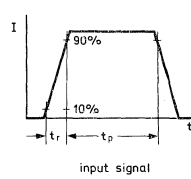
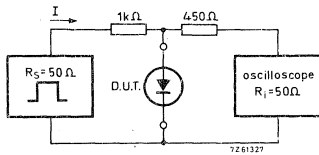

Input signal : Rise time of the forward pulse
Forward current pulse duration
Duty factor

$t_r = 20\text{ ns}$
 $t_p = 120\text{ ns}$
 $\delta = 0,01$

Oscilloscope: Rise time

$t_r = 0,35\text{ ns}$

Circuit capacitance $C \leq 1\text{ pF}$ ($C =$ oscilloscope input capacitance + parasitic capacitance)

Reverse recovery time when switched from

$I_F = 10\text{ mA to } I_R = 60\text{ mA}; R_L = 100\text{ }\Omega;$
measured at $I_R = 1\text{ mA}$

$t_{rr} < 4\text{ ns}$

Test circuit and waveforms:

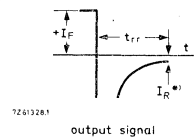
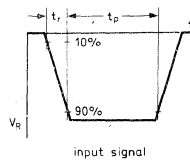
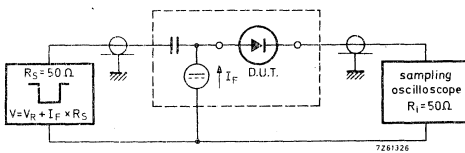

Input signal : Rise time of the reverse pulse
Reverse pulse duration
Duty factor

$t_r = 0,6\text{ ns}$
 $t_p = 100\text{ ns}$
 $\delta = 0,05$

*) $I_R = 1\text{ mA}$

Oscilloscope: Rise time

$t_r = 0,35\text{ ns}$

Circuit capacitance $C \leq 1\text{ pF}$ ($C =$ oscilloscope input capacitance + parasitic capacitance)

ULTRA-HIGH-SPEED SILICON DIODES

Whiskerless diodes in subminiature DO-35 envelopes.

The 1N4150 is primarily intended for general purpose use in computer and industrial applications. The 1N4151 and 1N4154 are intended for military and industrial applications.

		QUICK REFERENCE DATA			
			1N4150	1N4151	1N4154
Continuous reverse voltage	V_R	max.	50	50	25 V
Repetitive peak reverse voltage	V_{RRM}	max.	—	75	— V
Repetitive peak forward current	I_{FRM}	max.	0,60	0,45	0,45 A
Non-repetitive peak forward current	I_{FSM}	$t = 1 \mu s$	max. 4,0	—	— A
		$t = 1 s$	max. 0,5	—	— A
Forward voltage	V_F	<	—	—	1 V
$I_F = 30 \text{ mA}$	V_F	<	—	1	— V
$I_F = 50 \text{ mA}$	V_F	<	1	—	— V
$I_F = 200 \text{ mA}$	V_F	<	—	—	— V
Reverse recovery time when switched from $I_F = 400 \text{ mA}$ to $I_R = 400 \text{ mA}$; $R_L = 100 \Omega$; measured at $I_R = 40 \text{ mA}$	t_{rr}	<	6	—	— ns
$I_F = 10 \text{ mA}$ to $I_R = 10 \text{ mA}$; $R_L = 100 \Omega$; measured at $I_R = 1 \text{ mA}$	t_{rr}	<	—	4	4 ns

MECHANICAL DATA

Dimensions in mm

DO-35

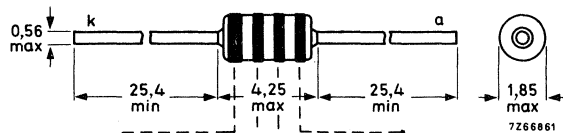

1N4150:	yellow	brown	green	black
1N4151:	yellow	brown	green	brown
1N4154:	yellow	brown	green	yellow

(cathode)

IN4150
IN4151
IN4154

RATINGS Limiting values in accordance with the Absolute Maximum System (IEC 134)

<u>Voltages</u>		IN4150	IN4151	IN4154
Continuous reverse voltage	V_R max.	50	50	25 V
Repetitive peak reverse voltage	V_{RRM} max.	-	75	- V
<u>Currents</u>				
Forward current (d. c.)	I_F max.	0,30	0,20	0,20 A
Repetitive peak forward current	I_{FRM} max.	0,60	0,45	0,45 A
Non-repetitive peak forward current	I_{FSM} max.	4,0	-	- A
t = 1 μ s	I_{FSM} max.	0,5	-	- A
t = 1 s				
Total power dissipation up to $T_{amb} = 25$ °C	P_{tot} max.		500	mW
<u>Derating factor</u>			2,85	mW/°C

Temperatures

Storage temperature	T_{stg}	-65 to +200	°C
Junction temperature	T_j max.	200	°C

CHARACTERISTICS

$T_j = 25$ °C unless otherwise specified

<u>Forward voltages</u>		IN4150	IN4151	IN4154
$I_F = 1$ mA	$V_F >$	0,54	-	- V
	$V_F <$	0,62	-	- V
$I_F = 10$ mA	$V_F >$	0,66	-	- V
	$V_F <$	0,74	-	- V
$I_F = 30$ mA	$V_F <$	-	-	1 V
$I_F = 50$ mA	$V_F >$	0,76	-	- V
	$V_F <$	0,86	1	- V
$I_F = 100$ mA	$V_F >$	0,82	-	- V
	$V_F <$	0,92	-	- V
$I_F = 200$ mA	$V_F >$	0,87	-	- V
	$V_F <$	1,00	-	- V
<u>Reverse avalanche breakdown voltage</u>				
$I_R = 5$ μ A	$V_{(BR)R} >$	-	75	35 V
<u>Reverse currents</u>				
$V_R = 25$ V	$I_R <$	-	-	0,1 μ A
$V_R = 25$ V; $T_{amb} = 150$ °C	$I_R <$	-	-	100 μ A
$V_R = 50$ V	$I_R <$	0,1	0,05	- μ A
$V_R = 50$ V; $T_{amb} = 150$ °C	$I_R <$	100	50	- μ A

CHARACTERISTICS (continued)

$T_j = 25\text{ }^\circ\text{C}$

Diode capacitance

$V_R = 0$; $f = 1\text{ MHz}$

	1N4150	1N4151	1N4154	
C_d	< 2,5	2	4	pF

Reverse recovery time when switched from

$I_F = 10\text{ to }200\text{ mA}$ to $I_R = 10\text{ to }200\text{ mA}$;
 $R_L = 100\ \Omega$; measured at $I_R = 0, 1 \times I_F$

t_{rr}	< 4	-	-	ns
----------	-----	---	---	----

$I_F = 200\text{ to }400\text{ mA}$ to $I_R = 200\text{ to }400\text{ mA}$;
 $R_L = 100\ \Omega$; measured at $I_R = 0, 1 \times I_F$

t_{rr}	< 6	-	-	ns
----------	-----	---	---	----

$I_F = 10\text{ mA}$ to $I_R = 1\text{ mA}$; $R_L = 100\ \Omega$;
measured at $I_R = 0, 1\text{ mA}$

t_{rr}	< 6	-	-	ns
----------	-----	---	---	----

$I_F = 10\text{ mA}$ to $I_R = 10\text{ mA}$; $R_L = 100\ \Omega$;
measured at $I_R = 1\text{ mA}$

t_{rr}	< -	4	4	ns
----------	-----	---	---	----

$I_F = 10\text{ mA}$ to $I_R = 60\text{ mA}$; $R_L = 100\ \Omega$;
measured at $I_R = 1\text{ mA}$

t_{rr}	< -	2	2	ns
----------	-----	---	---	----

Test circuit and waveforms:

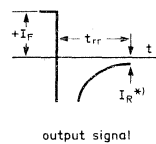
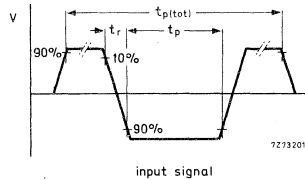
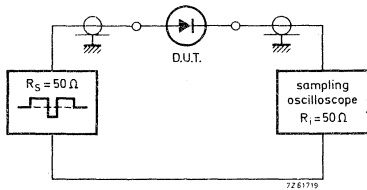

*) value at which t_{rr} is measured

Input signal : Total pulse duration
Duty factor
Rise time of the reverse pulse
Reverse pulse duration

$t_{p(tot)} = 0,2\ \mu\text{s}$
 $\delta = 0,0025$
 $t_r = 0,6\text{ ns}$
 $t_p = 30\text{ ns}$

Oscilloscope: Rise time

$t_r = 0,35\text{ ns}$

Circuit capacitance $C \leq 1\text{ pF}$ ($C =$ oscilloscope input capacitance + parasitic capacitance)

Forward recovery time when switched from

$I = 0$ to $I_F = 200\text{ mA}$; $t_r = 0,4\text{ ns}$; $t_p = 100\text{ ns}$; $\delta < 0,01$;
measured at $V_f = 1\text{ V}$

1N4150 $t_{fr} < 10\text{ ns}$

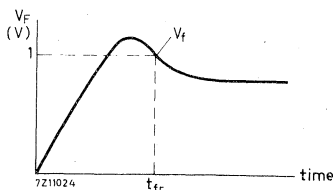

Special diodes



PICOAMPERE DIODE

Silicon diode in a metal envelope. It has an extremely low leakage current over a wide temperature range combined with a low capacitance and is not sensitive for light. It is intended for clamping, holding, peak follower, time delay circuits as well as for logarithmic amplifiers and protection of insulated gate field-effect transistors.

QUICK REFERENCE DATA			
Continuous reverse voltage	V_R	max.	20 V
Forward current (d. c.)	I_F	max.	50 mA
Forward voltage at $I_F = 10$ mA	V_F	<	1.0 V
Reverse current			
$V_R = 5$ V; $T_j = 25$ °C	I_R	<	5 pA
$V_R = 20$ V; $T_j = 25$ °C	I_R	<	10 pA
Diode capacitance			
$V_R = 0$; $f = 1$ MHz	C_d	<	1.3 pF

MECHANICAL DATA

Dimensions in mm

TO-18 (except for the two leads)

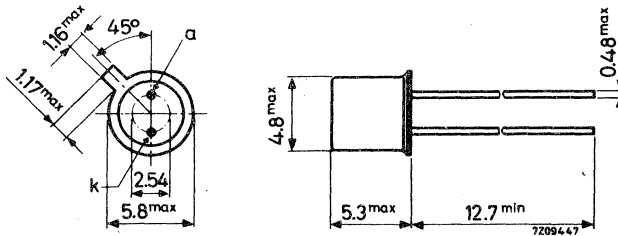

Handle the device with care during soldering into the circuit. The extremely low leakage current can only be guaranteed when the bottom is free from solder flux or other contaminations.

RATINGS Limiting values in accordance with the Absolute Maximum System (IEC 134)

Voltages

Continuous reverse voltage	V_R	max.	20	V
Repetitive peak reverse voltage	V_{RRM}	max.	35	V

Currents

Forward current (d. c. or average)	I_F	max.	50	mA
Repetitive peak forward current	I_{FRM}	max.	100	mA

Temperatures

Storage temperature	T_{stg}	-65 to +125	$^{\circ}C$
Junction temperature	T_j	max.	125 $^{\circ}C$

THERMAL RESISTANCE

From junction to ambient in free air	$R_{th\ j-a}$	=	0.5	$^{\circ}C/mW$
--------------------------------------	---------------	---	-----	----------------

CHARACTERISTICS

$T_j = 25\ ^{\circ}C$ unless otherwise specified

Forward voltage

$I_F = 10\ mA$	V_F	<	1.0	V
----------------	-------	---	-----	---

Reverse currents

$V_R = 5\ V$	I_R	<	5	pA
$V_R = 5\ V; T_j = 80\ ^{\circ}C$	I_R	<	250	pA
$V_R = 20\ V$	I_R	<	10	pA

Diode capacitance

$V_R = 0; f = 1\ MHz$	C_d	<	1.3	pF
-----------------------	-------	---	-----	----

CHARACTERISTICS (continued)

$T_j = 25\text{ }^\circ\text{C}$

Forward recovery voltage when switched to

$I_F = 10\text{ mA}$

$V_{fr} < 1,25\text{ V}$

Test circuit and waveforms :

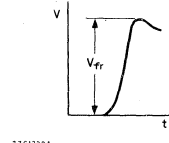
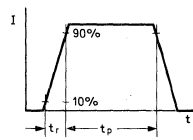
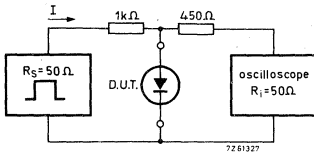

Input signal : Rise time of the forward pulse

$t_r \leq 20\text{ ns}$

Forward current pulse duration

$t_p = 300\text{ ns}$

Duty factor

$\delta = 0,01$

Oscilloscope: Rise time

$t_r = 0,35\text{ ns}$

Input capacitance

$C_i \leq 1\text{ pF}$

Circuit capacitance $C \leq 20\text{ pF}$ ($C = C_i + \text{parasitic capacitance}$)

Reverse recovery time when switched from

$I_F = 10\text{ mA}$ to $I_R = 10\text{ mA}$; $R_L = 100\text{ }\Omega$;

measured at $I_R = 1\text{ mA}$

$t_{rr} < 350\text{ ns}$

Test circuit and waveforms :

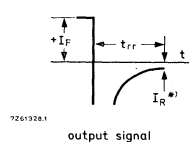
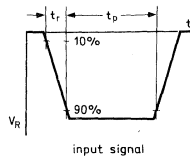
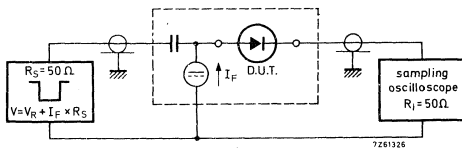

Input signal : Rise time of the reverse pulse

$t_r = 0,6\text{ ns}$

$I_R = 1\text{ mA}$

Reverse pulse duration

$t_p = 500\text{ ns}$

Duty factor

$\delta = 0,05$

Oscilloscope: Rise time

$t_r = 0,35\text{ ns}$

Circuit capacitance $C \leq 1\text{ pF}$ ($C = \text{oscilloscope input capacitance} + \text{parasitic capacitance}$)

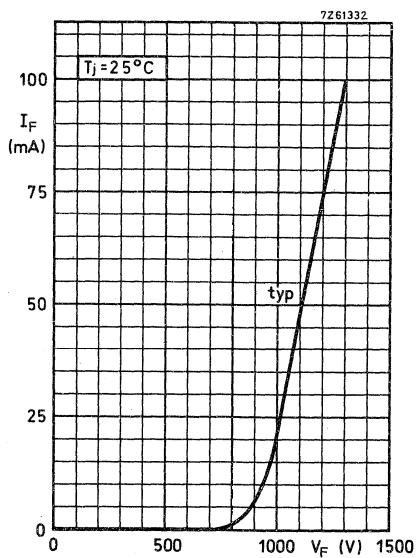
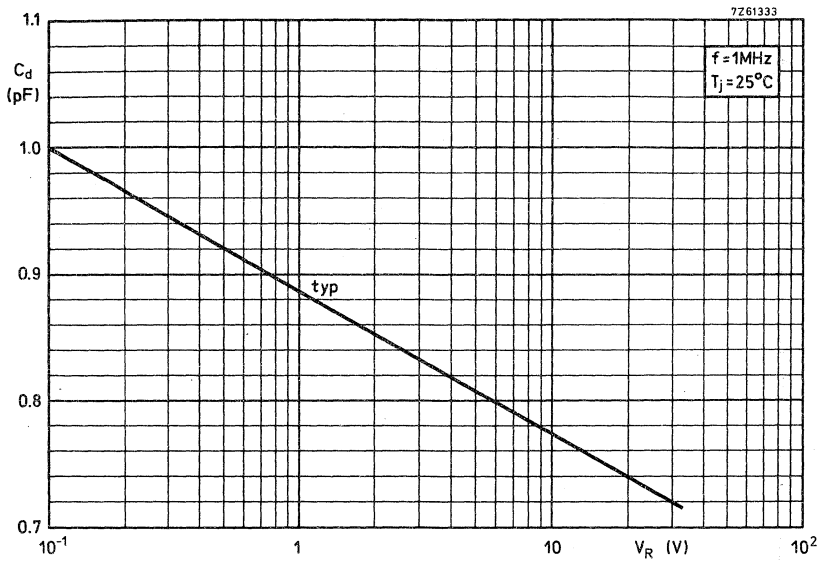

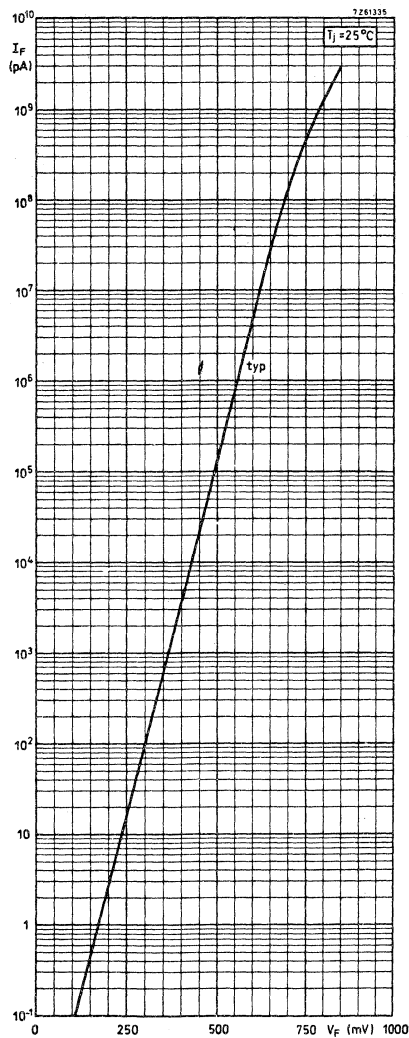

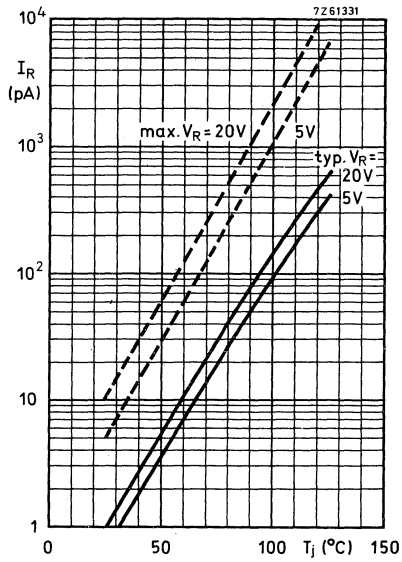
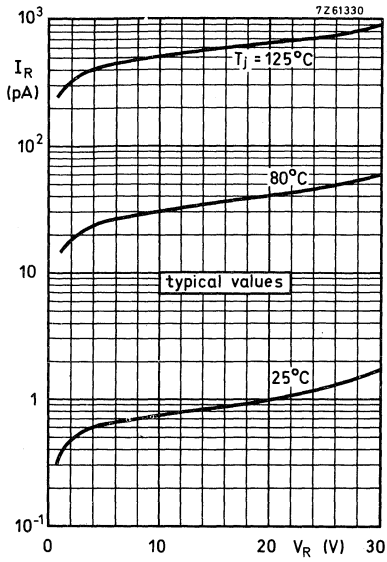

Voltage regulator diodes

VOLTAGE REGULATOR DIODES
in Handbook Part 1a

Nom. working voltage ($\pm 5\%$) V_Z (V)	1,5 W DO-1 metal	2,5 W plastic	10 W DO-4 metal	20 W DO-4 metal	75 W DO-5 metal
				Reverse polarity available	
4,7	-C4V7				
5,1	—				
5,6	—		BZZ14		
6,2	—		BZZ15		
6,8	—		BZZ16		
7,5	—		BZZ17		
8,2	—		BZZ18	-C7V5(R)	
9,1	-C9V1		BZZ19	—	
10	-C10	-C10	BZZ20	—	-C10(R)
11	—	—	BZZ21	—	—
12	—	—	BZZ22	—	—
13	—	—	BZZ23	—	—
15	—	—	BZZ24	—	—
16	—	—	BZZ25	—	—
18	—	—	BZZ26	—	—
20	—	—	BZZ27	—	—
22	—	—	BZZ28	—	—
24	—	—	BZZ29	—	—
27	—	—		—	—
30	—	—		—	—
33	—	—		—	—
36	—	—		—	—
39	—	—		—	—
43	—	—		—	—
47	—	—		—	—
51	—	—		—	—
56	—	—		—	—
62	—	—		—	—
68	—	—		—	—
75	-C75	-C75		-C75(R)	-C75(R)

VOLTAGE TOLERANCES

The following tables give the voltage tolerances that belong to a specified type.

E24 ($\pm 5\%$) range

nom.	min.	max.	
2,7	2,5	2,9	V
3,0	2,8	3,2	V
3,3	3,1	3,5	V
3,6	3,4	3,8	V
3,9	3,7	4,1	V
4,3	4,0	4,6	V
4,7	4,4	5,0	V
5,1	4,8	5,4	V
5,6	5,2	6,0	V
6,2	5,8	6,6	V
6,8	6,4	7,2	V
7,5	7,0	7,9	V
8,2	7,7	8,7	V
9,1	8,5	9,6	V
10,0	9,4	10,6	V
11,0	10,4	11,6	V
12,0	11,4	12,7	V
13,0	12,4	14,1	V
15,0	13,8	15,6	V
16,0	15,3	17,1	V
18,0	16,8	19,1	V
20,0	18,8	21,2	V
22,0	20,8	23,3	V
24,0	22,8	25,6	V
27,0	25,1	28,9	V

$\pm 2\%$ range

nom.	min.	max.	
2,7	2,65	2,75	V
3,0	2,94	3,06	V
3,3	3,23	3,37	V
3,6	3,53	3,67	V
3,9	3,82	3,98	V
4,3	4,21	4,39	V
4,7	4,61	4,79	V
5,1	5,00	5,20	V
5,6	5,49	5,71	V
6,2	6,08	6,32	V
6,8	6,66	6,94	V
7,5	7,35	7,65	V
8,2	8,04	8,36	V
9,1	8,92	9,28	V
10,0	9,80	10,2	V
11,0	10,8	11,2	V
12,0	11,8	12,2	V
13,0	12,7	13,3	V
15,0	14,7	15,3	V
16,0	15,7	16,3	V
18,0	17,6	18,4	V
20,0	19,6	20,4	V
22,0	21,6	22,4	V
24,0	23,5	24,5	V
27,0	26,5	27,5	V

The values in tables above multiplied by 10 will be the values for higher voltages.

LOW VOLTAGE STABISTOR

Silicon planar epitaxial diode in a DO-35 envelope. The diode is intended for low voltage stabilizing e.g. bias stabilizer in class-B output stages, clipping, clamping and meter protection.

QUICK REFERENCE DATA				
Repetitive peak forward current	I_{FRM}	max.	250	mA
Storage temperature	T_{stg}		-65 to +200	°C
Junction temperature	T_j	max.	200	°C
Thermal resistance from junction to ambient	$R_{th\ j-a}$	=	0,38	°C/mW
Forward voltage at $I_F = 0,1$ mA	V_F		610 to 690	mV
$I_F = 1,0$ mA	V_F		680 to 760	mV
$I_F = 10$ mA	V_F		750 to 830	mV
$I_F = 100$ mA	V_F		870 to 960	mV
Diode capacitance at $V_R = 0$; $f = 1$ MHz	C_d	<	140	pF

MECHANICAL DATA

Dimensions in mm

DO-35

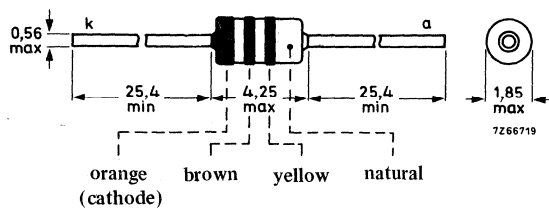

RATINGS Limiting values in accordance with the Absolute Maximum System (IEC134)

Current

Repetitive peak forward current I_{FRM} max. 250 mA

Temperatures

Storage temperature T_{stg} -65 to +200 °C

Junction temperature T_j max. 200 °C

THERMAL RESISTANCE

From junction to ambient in free air $R_{th\ j-a}$ = 0,38 °C/mW

CHARACTERISTICS

$T_j = 25\text{ °C}$

Forward voltage

$I_F = 0,1\text{ mA}$ V_F 610 to 690 mV

$I_F = 1,0\text{ mA}$ V_F 680 to 760 mV

$I_F = 5,0\text{ mA}$ V_F 730 to 810 mV

$I_F = 10\text{ mA}$ V_F 750 to 830 mV

$I_F = 100\text{ mA}$ V_F 870 to 960 mV

Reverse current

$V_R = 4\text{ V}$ I_R < 5 μA

Temperature coefficient at $I_F = 1\text{ mA}$

S_F typ. -1,8 mV/°C

Differential resistance at $f = 1\text{ kHz}$

$I_F = 1\text{ mA}$ r_{diff} typ. 30 Ω

$I_F = 10\text{ mA}$ r_{diff} typ. 3,5 Ω
 < 6,0 Ω

Diode capacitance

$V_R = 0; f = 1\text{ MHz}$ C_d < 140 pF

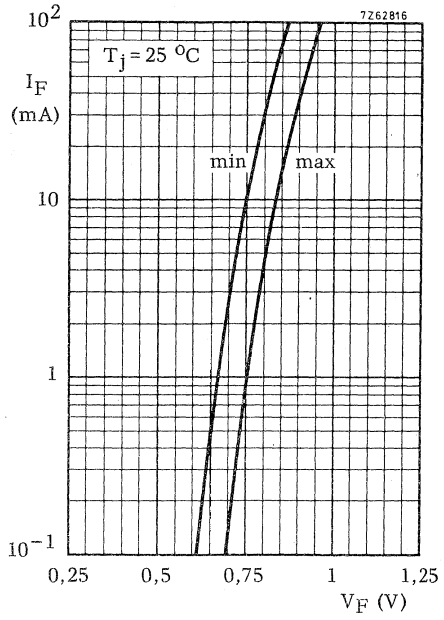

LOW VOLTAGE STABISTOR

Silicon planar epitaxial diode in a DO-35 envelope primarily intended for low voltage stabilizing.

QUICK REFERENCE DATA			
Repetitive peak reverse voltage	V_{RRM}	max.	5 V
Repetitive peak forward current	I_{FRM}	max.	225 mA
Storage temperature	T_{stg}		-65 to +200 °C
Junction temperature	T_j	max.	200 °C
Thermal resistance from junction to ambient	$R_{th j-a}$	=	0,60 °C/mW
Forward voltage at $I_F = 0,1$ mA	V_F		480 to 540 mV
	V_F		590 to 660 mV
	V_F		710 to 790 mV
	V_F		875 to 1050 mV
Diode capacitance at $V_R = 0; f = 1$ MHz	C_d	<	3,0 pF

MECHANICAL DATA

Dimensions in mm

DO-35

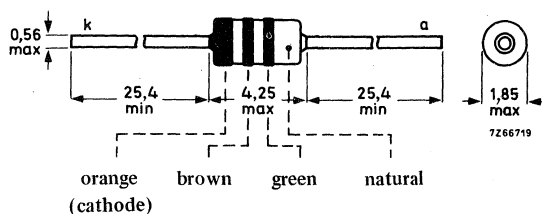

RATINGS Limiting values in accordance with the Absolute Maximum System (IEC134)

Voltage

Repetitive peak reverse voltage V_{RRM} max. 5 V

Currents

Average rectified forward current (averaged over any 20 ms period) $I_{F(AV)}$ max. 100 mA ¹⁾

Forward current (d. c.) I_F max. 100 mA

Repetitive peak forward current I_{FRM} max. 225 mA

Non-repetitive peak forward current; $t = 1 \mu s$ I_{FSM} max. 2000 mA
 $t = 1 s$ I_{FSM} max. 500 mA

Temperatures

Storage temperature T_{stg} -65 to +200 °C

Junction temperature T_j max. 200 °C

THERMAL RESISTANCE

From junction to ambient in free air $R_{th j-a}$ = 0,60 °C/mW

CHARACTERISTICS

$T_j = 25 \text{ °C}$

Forward voltage

$I_F = 0,1 \text{ mA}$ V_F 480 to 540 mV

$I_F = 1,0 \text{ mA}$ V_F 590 to 660 mV

$I_F = 5,0 \text{ mA}$ V_F 670 to 740 mV

$I_F = 10 \text{ mA}$ V_F 710 to 790 mV

$I_F = 100 \text{ mA}$ V_F 875 to 1050 mV

Reverse current

$V_R = 5 \text{ V}$ I_R < 1500 nA

Temperature coefficient at $I_F = 1 \text{ mA}$ S_F typ. -2,1 mV/°C

→ Differential resistance at $f = 1 \text{ kHz}$

$I_F = 1 \text{ mA}$ r_{diff} typ. 50 Ω

$I_F = 10 \text{ mA}$ r_{diff} typ. 6 Ω
 < 7 Ω

Diode capacitance

$V_R = 0; f = 1 \text{ MHz}$ C_d < 3,0 pF

→ 1) For sinusoidal operation $I_{F(AV)} = 75 \text{ mA}$.

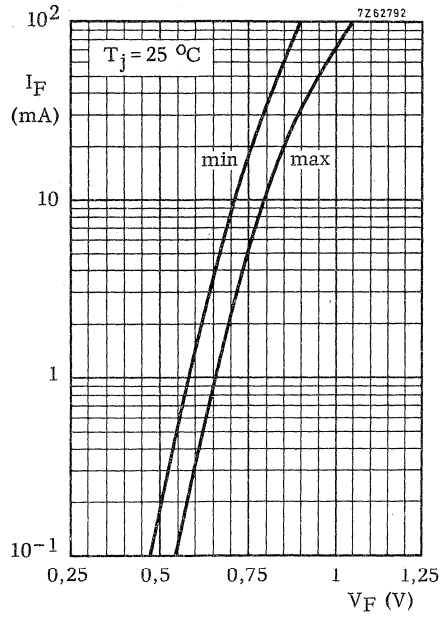

VOLTAGE REGULATOR DIODES

Silicon planar diodes in a DO-35 envelope intended for use as low voltage stabilizers or voltage references.

The series covers the normalized range of nominal working voltages from 4,7 V to 75 V with a tolerance of $\pm 5\%$ (international standard E24).

QUICK REFERENCE DATA			
Working voltage range	V_Z	nom.	4,7 to 75 V
Total power dissipation	P_{tot}	max.	400 mW 1)
		max.	500 mW 2)
Non-repetitive peak reverse power dissipation	P_{ZSM}	max.	30 W
Junction temperature	T_j	max.	200 °C
Thermal resistance from junction to ambient	$R_{th\ j-a}$	=	0,38 °C/mW 3)

1) In still air at maximum lead length up to $T_{amb} = 50\text{ °C}$.

2) If leads are kept at $T_{amb} = 25\text{ °C}$ at 8 mm from body.

3) Measured in still air at maximum lead length.

MECHANICAL DATA

Dimensions in mm

DO-35

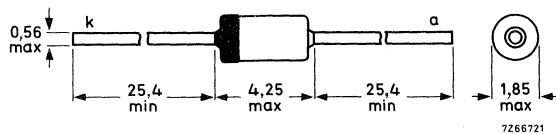

Cathode indicated by coloured band

BZX55 SERIES

RATINGS Limiting values in accordance with the Absolute Maximum System (IEC 134)

Currents

Average forward current (averaged
over any 20 ms period)

$I_{F(AV)}$ max. 250 mA

Repetitive peak forward current

I_{FRM} max. 250 mA

Power dissipation

Total power dissipation

P_{tot} max. 400 mW 1)
max. 500 mW 2)

Non-repetitive peak reverse power dissipation
 $t = 100 \mu s; T_j = 150 \text{ }^\circ C$

P_{ZSM} max. 30 W

Temperatures

Storage temperature

T_{stg} -65 to +200 $^\circ C$

Junction temperature

T_j max. 200 $^\circ C$

THERMAL RESISTANCE

From junction to ambient in free air
at maximum lead length

$R_{th j-a} = 0,38 \text{ }^\circ C/mW$ 3)

CHARACTERISTICS

Forward voltage

→ $I_F = 100 \text{ mA}; T_{amb} = 25 \text{ }^\circ C$

$V_F < 1,0 \text{ V}$

Reverse current

at $T_j = 25$ | 150 $^\circ C$

BZX55-C4V7	$V_R = 1$	V
C5V1	$V_R = 1$	V
C5V6	$V_R = 1$	V
C6V2	$V_R = 2$	V
C6V8	$V_R = 3$	V
C7V5	$V_R = 5$	V
C8V2 to C75	$V_R = 0,75$	V_{Znom}

I_R	< 500	10000 nA
I_R	< 100	2000 nA
I_R	< 100	2000 nA
I_R	< 100	2000 nA
I_R	< 100	2000 nA
I_R	< 100	2000 nA
I_R	< 100	2000 nA

1) In still air at maximum lead length up to $T_{amb} = 50 \text{ }^\circ C$.

2) If leads are kept at $T_{amb} = 25 \text{ }^\circ C$ at 8 mm from body.

3) Measured in still air at maximum lead length.

CHARACTERISTICS (continued)

$T_j = 25\text{ }^\circ\text{C}$

BZX55-...	Working voltage		Differential resistance		Temperature coefficient
	V_Z (V)		r_{diff} (Ω)		S_Z (mV/ $^\circ\text{C}$)
	at $I_Z = 5\text{ mA}$		at $I_Z = 5\text{ mA}$	at $I_Z = 1\text{ mA}$	at $I_Z = 5\text{ mA}$
	min.	max.	max.	max.	typ.
C4V7	4,4	5,0	60	600	-1,2
C5V1	4,8	5,4	35	550	1,0
C5V6	5,2	6,0	25	450	1,6
C6V2	5,8	6,6	10	200	2,5
C6V8	6,4	7,2	8	150	3,0
C7V5	7,0	7,9	7	50	3,8
C8V2	7,7	8,7	7	50	4,5
C9V1	8,5	9,6	10	50	5,5
C10	9,4	10,6	15	70	6,5
C11	10,4	11,6	20	70	7,7
C12	11,4	12,7	20	90	8,4
C13	12,4	14,1	26	110	9,8
C15	13,8	15,6	30	110	11,3
C16	15,3	17,1	40	170	12,8
C18	16,8	19,1	50	170	14,4
C20	18,8	21,2	55	220	16,0
C22	20,8	23,3	55	220	18,7
C24	22,8	25,6	80	220	20,4
C27	25,1	28,9	80	220	22,9
C30	28,0	32,0	80	220	27,0
C33	31,0	35,0	80	220	29,7
C36	34,0	38,0	80	220	32,4
	at $I_Z = 2,5\text{ mA}$		at $I_Z = 2,5\text{ mA}$	at $I_Z = 0,5\text{ mA}$	at $I_Z = 2,5\text{ mA}$
	min.	max.	max.	max.	typ.
C39	37,0	41,0	90	500	35,1
C43	40,0	46,0	90	600	38,7
C47	44,0	50,0	110	700	44,0
C51	48,0	54,0	125	700	49,0
C56	52,0	60,0	135	1000	55,0
C62	58,0	66,0	150	1000	62,0
C68	64,0	72,0	180	1000	70,0
C75	70,0	79,0	220	1000	78,0

BZX55 SERIES

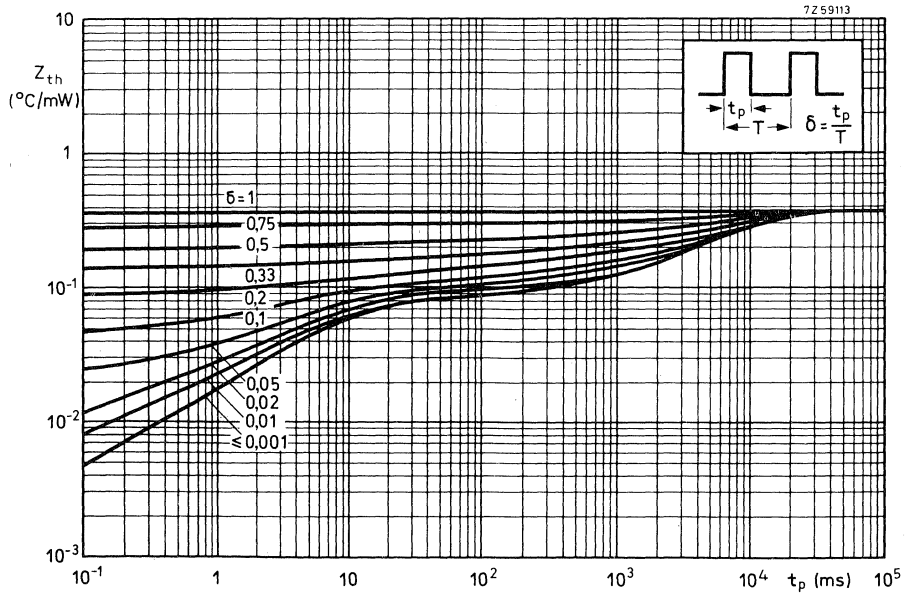
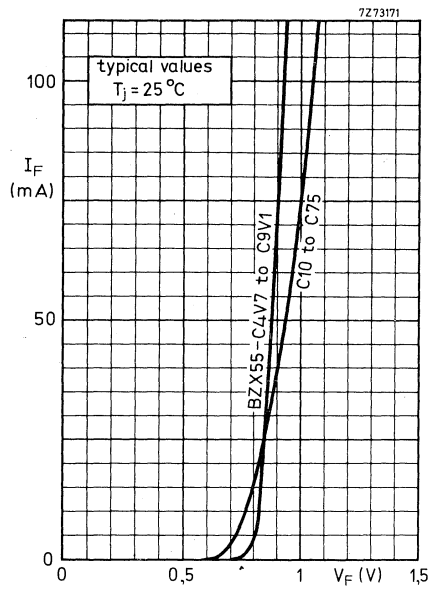
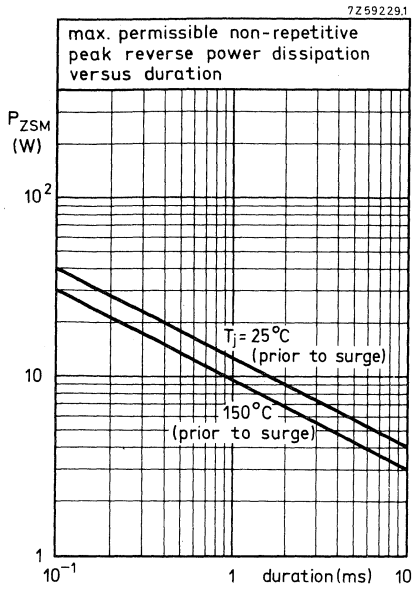

VOLTAGE REGULATOR DIODES

Silicon diodes in a SOD-22 plastic envelope intended as general purpose medium power voltage regulators.

The series consists of 25 types with nominal working voltages ranging from 7,5 V to 75 V with a tolerance of $\pm 5\%$ (E24).

QUICK REFERENCE DATA			
Working voltage range		nom.	7,5 to 75 V
Working voltage tolerance (E24)			± 5 %
Peak working current	I_{ZM}	max.	3,0 A
Total power dissipation up to $T_{amb} = 25$ °C	P_{tot}	max.	1,3 W
Repetitive peak reverse power dissipation	P_{ZRM}	max.	6,0 W
Junction temperature	T_j	max.	175 °C

MECHANICAL DATA

Dimensions in mm

SOD-22

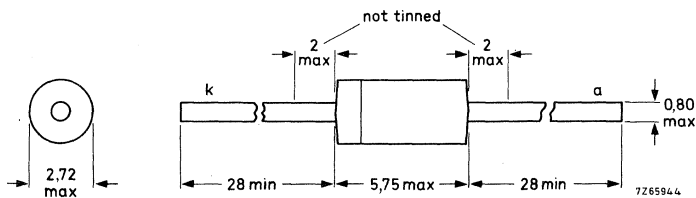

Cathode indicated by white band

The sealing of the plastic envelope withstands the accelerated damp heat test of IEC recommendation 68-2 (test D, severity IV, 6 cycles).

SOLDERING AND MOUNTING NOTES

1. Soldered joints must be at least 5 mm from the seal.
2. The maximum permissible temperature of the soldering iron or bath is 245 °C; it must be in contact with the joint for no more than 5 seconds.
3. Avoid hot spots due to handling or mounting; the body of the device must not come into contact with or be exposed to a temperature higher than 175 °C.

BZX61 SERIES

RATINGS Limiting values in accordance with the Absolute Maximum System (IEC134)

Currents

Peak working current	I_{ZM}	max.	3,0 A
Repetitive peak forward current	I_{FRM}	max.	1,0 A

Power dissipation (see graphs on pages 2 and 3)

Total power dissipation up to $T_{amb} = 25\text{ }^{\circ}\text{C}$	P_{tot}	max.	1,3 W
Repetitive peak reverse power dissipation	P_{ZRM}	max.	6,0 W
Non-repetitive peak reverse power dissipation $t_p = 100\text{ }\mu\text{s}; T_{amb} = -55\text{ to }+25\text{ }^{\circ}\text{C}$	P_{ZSM}	max.	300 W

Temperatures

Storage temperature	T_{stg}	-65 to +175 $^{\circ}\text{C}$
Junction temperature	T_j	max. 175 $^{\circ}\text{C}$

THERMAL RESISTANCE

see graphs on pages 2 and 3

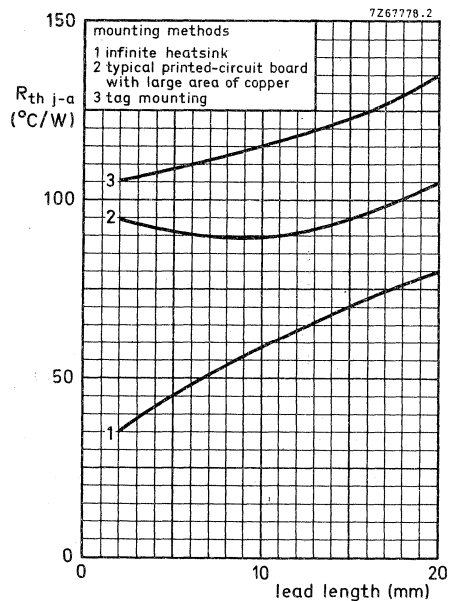
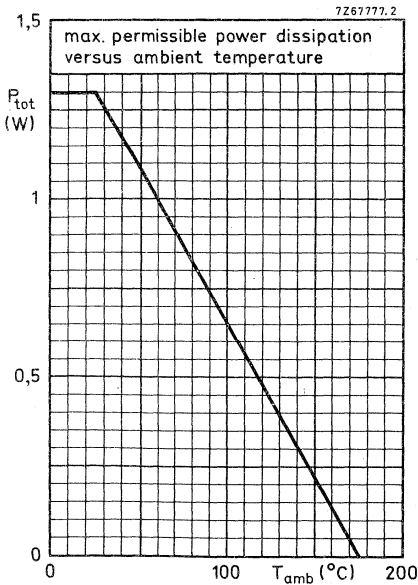

**BZX61
SERIES**

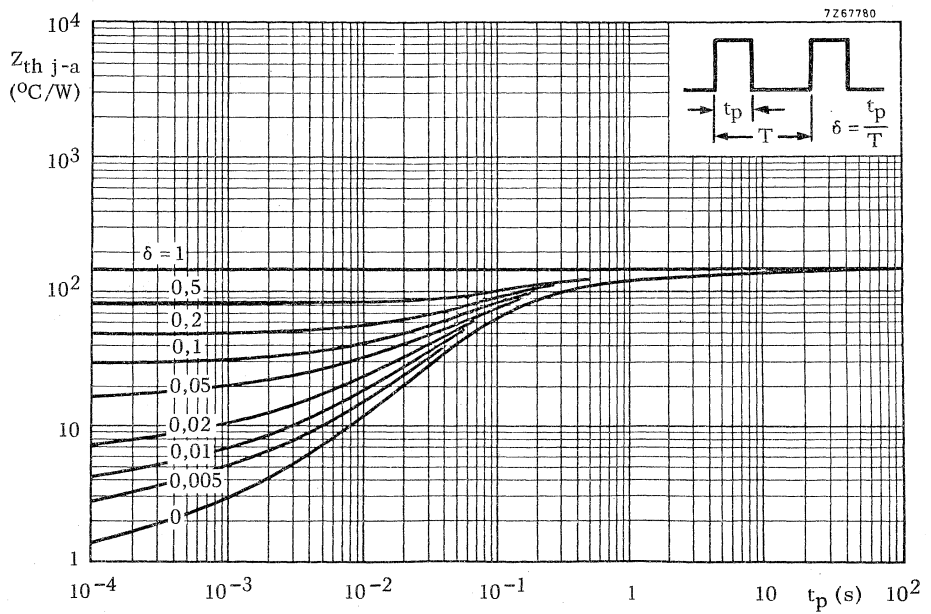
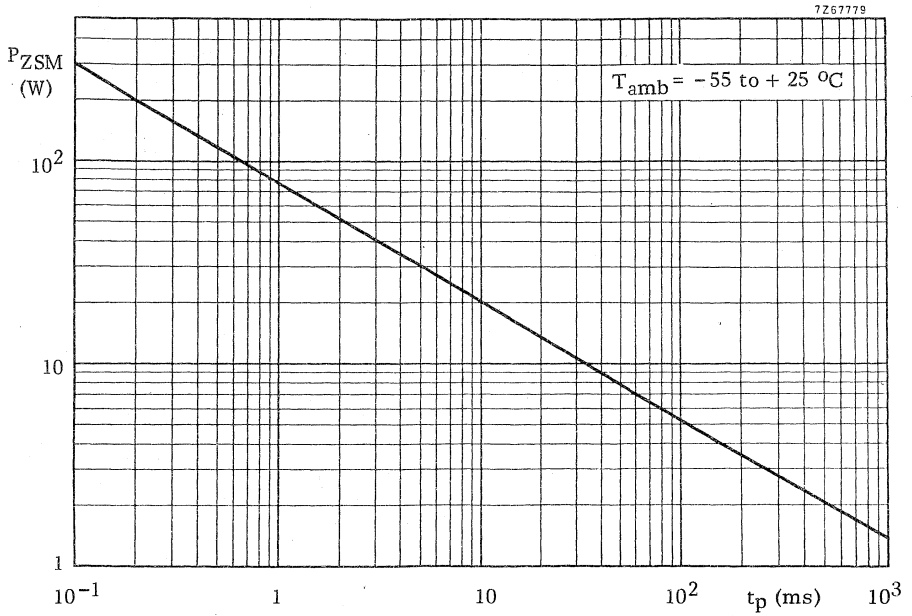

BZX61 SERIES

CHARACTERISTICS

$T_j = 25\text{ }^\circ\text{C}$ unless otherwise specified

Forward voltage

$I_F = 100\text{ mA}$; $T_{amb} = 25\text{ }^\circ\text{C}$

V_F typ. 0,86 V
< 1,50 V

BZX61-...	Working voltage			Temperature coefficient	Differential resistance	Reverse current	at	Reverse voltage
	V_Z (V)			S_Z (mV/ $^\circ\text{C}$)	r_{diff} (Ω)	I_R (μA)		V_R (V)
	at $I_Z = 20\text{ mA}$			at $I_Z = 20\text{ mA}$	at $I_Z = 20\text{ mA}$	max.		
	min.	nom.	max.	typ.	max.			
C7V5	7,0	7,5	7,9	+3,0	5,0	5		3
C8V2	7,7	8,2	8,7	+3,3	7,5	5		3
C9V1	8,5	9,1	9,6	+4,6	8,0	5		5
C10	9,4	10,0	10,6	+5,0	8,5	5		7
C11	10,4	11,0	11,6	+5,5	9,0	5		7
C12	11,4	12,0	12,7	+6,0	9,0	5		8
C13	12,4	13,0	14,1	+6,5	10,0	5		9
C15	13,8	15,0	15,6	+9,0	14,0	5		10
	at $I_Z = 10\text{ mA}$			at $I_Z = 10\text{ mA}$	at $I_Z = 10\text{ mA}$			
	min.	nom.	max.	typ.	max.	max.		
C16	15,3	16	17,1	+10	16	5		11
C18	16,8	18	19,1	+11	20	5		13
C20	18,8	20	21,2	+12	22	5		14
C22	20,8	22	23,3	+13	23	5		15
C24	22,7	24	25,9	+14	25	5		17
C27	25,1	27	28,9	+16	35	5		19
C30	28	30	32	+21	40	5		21
C33	31	33	35	+23	45	5		23
C36	34	36	38	+25	50	5		25
	at $I_Z = 5\text{ mA}$			at $I_Z = 5\text{ mA}$	at $I_Z = 5\text{ mA}$			
	min.	nom.	max.	typ.	max.	max.		
C39	37	39	41	+27	60	5		27
C43	40	43	46	+30	70	5		30
C47	44	47	50	+38	80	5		33
C51	48	51	54	+41	95	5		36
C56	52	56	60	+45	105	5		39
C62	58	62	66	+50	110	5		43
C68	64	68	72	+54	120	5		48
C75	70	75	79	+60	135	5		52

STABISTORS

Diodes with controlled conductance in a all-glass DO-7 envelope intended for low voltage regulation in circuits for clipping, coupling, clamping, meter protection, bias regulation and in many applications which require tight tolerances and low voltage levels. The series consists of 4 types with nominal voltages ranging from 1,4 to 3,6V with a tolerance of $\pm 5\%$.

QUICK REFERENCE DATA			
Regulation voltage range	V_F	nom.	1, 4 to 3, 6 V
Regulation voltage tolerance			± 5 %
Continuous reverse voltage	V_R	max.	10 V
Repetitive peak reverse voltage	V_{RRM}	max.	10 V
Repetitive peak forward current	I_{FRM}	max.	250 mA
Total power dissipation up to $T_{amb} = 32$ °C	P_{tot}	max.	400 mW
Operating junction temperature	T_j	max.	200 °C

MECHANICAL DATA

Dimensions in mm

DO-7

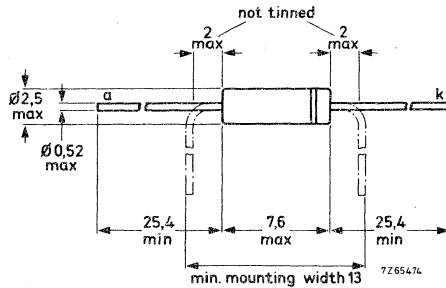

Cathode indicated by coloured band

BZX75
SERIES

RATINGS Limiting values in accordance with the Absolute Maximum System (IEC134)

Voltages

Continuous reverse voltage V_R max. 10 V

Repetitive peak reverse voltage V_{RRM} max. 10 V

Current

Repetitive peak forward current I_{FRM} max. 250 mA

Power dissipation

Total power dissipation up to $T_{amb} = 32\text{ }^\circ\text{C}$ P_{tot} max. 400 mW

Temperatures

Storage temperature T_{stg} -65 to +175 $^\circ\text{C}$

Operating junction temperature T_j max. 200 $^\circ\text{C}$

THERMAL RESISTANCE

From junction to ambient in free air $R_{th\ j-a} = 0,42\text{ }^\circ\text{C/mW}$



CHARACTERISTICS

$T_j = 25\text{ }^\circ\text{C}$

	Regulation voltage		Temperature coefficient		Differential resistance	
	V_F (V)		S_F (mV/°C)		r_{diff} (Ω); $f = 1\text{ kHz}$	
	at $I_F = 1\text{ mA}$		at $I_F = 1\text{ mA}$		at $I_F = 1\text{ mA}$	
BZX75-....	min.	max.	typ.		typ.	
C1V4	1,16	1,34	-4		60	
C2V1	1,75	2,05	-6		90	
C2V8	2,33	2,70	-8		120	
C3V6	3,02	3,45	-10		150	
	at $I_F = 10\text{ mA}$		at $I_F = 10\text{ mA}$		at $I_F = 10\text{ mA}$	
	min.	nom.	max.	typ.	typ.	max.
C1V4	1,33	1,40	1,47	-3,3	6	10
C2V1	1,99	2,10	2,21	-5,0	9	15
C2V8	2,66	2,80	2,94	-6,6	12	20
C3V6	3,42	3,60	3,78	-8,2	15	25

Reverse current

$V_R = 5\text{ V}$

BZX75-C1V4 } BZX75-C2V1 }	$I_R < 500\text{ nA}$
BZX75-C2V8 } BZX75-C3V6 }	$I_R < 200\text{ nA}$

Recovered charge when switched from

$I_F = 10\text{ mA}$ to $V_R = 5\text{ V}$; $R_L = 500\text{ }\Omega$

$Q_s > 600\text{ pC}$

Diode capacitance

$V_R = 0$; $f = 1\text{ MHz}$

$C_d < 250\text{ pF}$



BZX75 SERIES

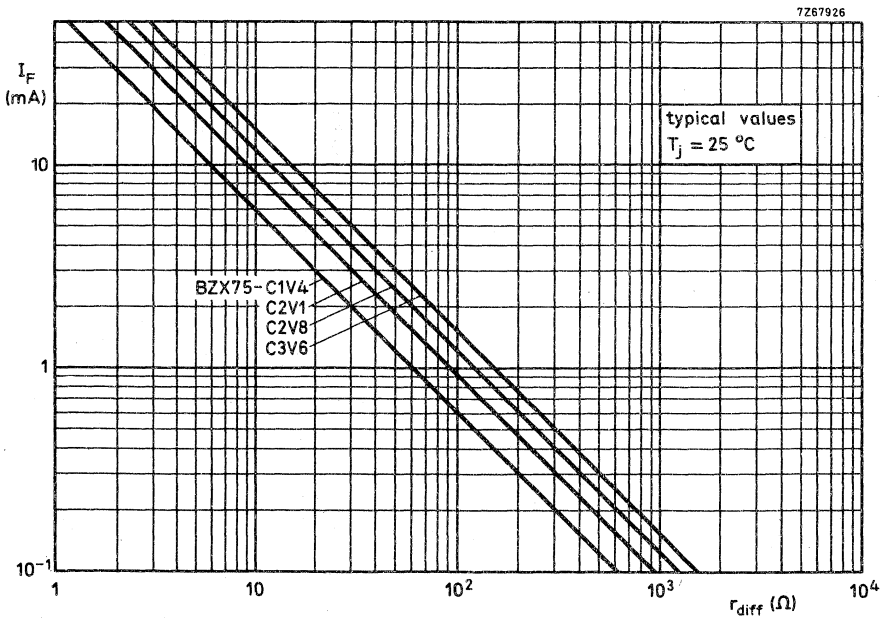
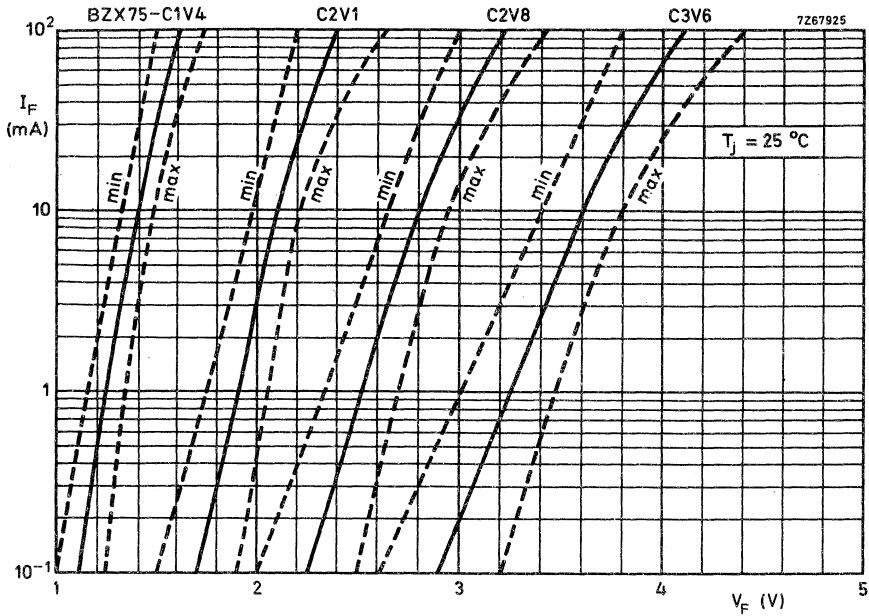

VOLTAGE REGULATOR DIODES

Silicon planar diodes in a DO-35 envelope intended for use as low voltage stabilisers or voltage references.

Available in two series; one to the international standardized E24 ($\pm 5\%$) range and the other with $\pm 2\%$ tolerance on working voltage.

Each series consists of 30 types with nominal working voltages ranging from 4,7V to 75V.

QUICK REFERENCE DATA			
Working voltage range	V_Z	nom. 4,7 to 75 V	
Total power dissipation	P_{tot}	max.	400 mW 1)
		max.	500 mW 2)
Non-repetitive peak reverse power dissipation	P_{ZSM}	max.	30 W
Junction temperature	T_j	max.	200 °C
Thermal resistance from junction to ambient	$R_{th j-a}$	=	0,38 °C/mW 3)

1) In still air at maximum lead length up to $T_{amb} = 50$ °C

2) If leads are kept at $T_{amb} = 25$ °C at 8 mm from body.

3) Measured in still air at maximum lead length.

MECHANICAL DATA

Dimensions in mm

DO-35

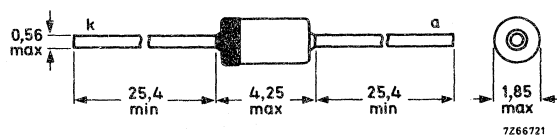

Cathode indicated by coloured band

BZX79 SERIES

RATINGS Limiting values in accordance with the Absolute Maximum System (IEC134)

Currents

Average forward current (averaged
over any 20 ms period)

$I_{F(AV)}$ max. 250 mA

Repetitive peak forward current

I_{FRM} max. 250 mA

Power dissipation

Total power dissipation

P_{tot} max. 400 mW 1)
max. 500 mW 2)

Non-repetitive peak reverse power dissipation
 $t = 100 \mu s$; $T_j = 150 \text{ }^\circ\text{C}$

P_{ZSM} max. 30 W

Temperatures

Storage temperature

T_{stg} -65 to +200 $^\circ\text{C}$

Junction temperature

T_j max. 200 $^\circ\text{C}$

THERMAL RESISTANCE

From junction to ambient in free air
at maximum lead length

$R_{th j-a} = 0,38 \text{ }^\circ\text{C/mW}$ 3)

CHARACTERISTICS

$T_j = 25 \text{ }^\circ\text{C}$ unless otherwise specified

Forward voltage

$I_F = 10 \text{ mA}$; $T_{amb} = 25 \text{ }^\circ\text{C}$

$V_F < 0,9 \text{ V}$

Reverse current

BZX79-.4V7 $V_R = 2 \text{ V}$
 .5V1 $V_R = 2 \text{ V}$
 .5V6 $V_R = 2 \text{ V}$
 .6V2 $V_R = 4 \text{ V}$
 .6V8 $V_R = 4 \text{ V}$
 .7V5 $V_R = 5 \text{ V}$
 .8V2 $V_R = 5 \text{ V}$
 .9V1 $V_R = 6 \text{ V}$
 .10 $V_R = 7 \text{ V}$
 .11 to .13 $V_R = 8 \text{ V}$
 .15 to .75 $V_R = 0,7 V_{Znom}$
 . = B for 2% tolerance
 . = C for E24 (5%) tolerance

$I_R < 3000 \text{ nA}$
 $I_R < 2000 \text{ nA}$
 $I_R < 1000 \text{ nA}$
 $I_R < 3000 \text{ nA}$
 $I_R < 2000 \text{ nA}$
 $I_R < 1000 \text{ nA}$
 $I_R < 700 \text{ nA}$
 $I_R < 500 \text{ nA}$
 $I_R < 200 \text{ nA}$
 $I_R < 100 \text{ nA}$
 $I_R < 50 \text{ nA}$

- 1) In still air at maximum lead length up to $T_{amb} = 50 \text{ }^\circ\text{C}$.
- 2) If leads are kept at $T_{amb} = 25 \text{ }^\circ\text{C}$ at 8 mm from body.
- 3) Measured in still air at maximum lead length.

CHARACTERISTICS (continued)

$T_j = 25\text{ }^\circ\text{C}$

E24 ($\pm 5\%$) logarithmic range (for $\pm 2\%$ tolerance range see page 5).

BZX79-...	Working voltage		Differential resistance		Temperature coefficient			Diode capacitance	
	V_Z (V)		r_{diff} (Ω)		S_Z (mV/ $^\circ\text{C}$)			C_d (pF); $f = 1\text{ MHz}$	
	at $I_Z = 5\text{ mA}$		at $I_Z = 5\text{ mA}$		at $I_Z = 5\text{ mA}$			$V_R = 0$	
	min.	max.	typ.	max.	min.	typ.	max.	typ.	max.
C4V7	4,4	5,0	50	80	-3,5	-1,4	0,2	130	180
C5V1	4,8	5,4	40	60	-2,7	-0,8	1,2	110	160
C5V6	5,2	6,0	15	40	-2,0	1,2	2,5	95	140
C6V2	5,8	6,6	6	10	0,4	2,3	3,7	90	130
C6V8	6,4	7,2	6	15	1,2	3,0	4,5	85	110
C7V5	7,0	7,9	6	15	2,5	4,0	5,3	80	100
C8V2	7,7	8,7	6	15	3,2	4,6	6,2	75	95
C9V1	8,5	9,6	6	15	3,8	5,5	7,0	70	90
C10	9,4	10,6	8	20	4,5	6,4	8,0	70	90
C11	10,4	11,6	10	20	5,4	7,4	9,0	65	85
C12	11,4	12,7	10	25	6,0	8,4	10,0	65	85
C13	12,4	14,1	10	30	7,0	9,4	11,0	60	80
C15	13,8	15,6	10	30	9,2	11,4	13,0	55	75
C16	15,3	17,1	10	40	10,4	12,4	14,0	52	75
C18	16,8	19,1	10	45	12,4	14,4	16,0	47	70
C20	18,8	21,2	15	55	14,4	16,4	18,0	36	60
C22	20,8	23,3	20	55	16,4	18,4	20,0	34	60
C24	22,8	25,6	25	70	18,4	20,4	22,0	33	55
	at $I_Z = 2\text{ mA}$		at $I_Z = 2\text{ mA}$		at $I_Z = 2\text{ mA}$				
	min.	max.	typ.	max.	min.	typ.	max.	typ.	max.
C27	25,1	28,9	25	80	21,4	23,4	25,3	30	50
C30	28,0	32,0	30	80	24,4	26,6	29,4	27	50
C33	31,0	35,0	35	80	27,4	29,7	33,4	25	45
C36	34,0	38,0	35	90	30,4	33,0	37,4	23	45
C39	37,0	41,0	40	130	33,4	36,4	41,2	21	45
C43	40,0	46,0	45	150	37,6	41,2	46,6	21	40
C47	44,0	50,0	50	170	42,0	46,1	51,8	19	40
C51	48,0	54,0	60	180	46,6	51,0	57,2	19	40
C56	52,0	60,0	70	200	52,2	57,0	63,8	18	40
C62	58,0	66,0	80	215	58,8	64,4	71,6	17	35
C68	64,0	72,0	90	240	65,6	71,7	79,8	17	35
C75	70,0	79,0	95	255	73,4	80,2	88,6	16,5	35



BZX79
SERIES

CHARACTERISTICS (continued)

$T_j = 25\text{ }^\circ\text{C}$

E24 ($\pm 5\%$) logarithmic range (for $\pm 2\%$ tolerance range see page 6).

BZX79-...	Working voltage			Differential resistance		Working voltage			Differential resistance	
	V_Z (V)			r_{diff} (Ω)		V_Z (V)			r_{diff} (Ω)	
	at $I_Z = 1\text{ mA}$			at $I_Z = 1\text{ mA}$		at $I_Z = 20\text{ mA}$			at $I_Z = 20\text{ mA}$	
	min.	nom.	max.	typ.	max.	min.	nom.	max.	typ.	max.
C4V7	3,7	4,2	4,7	425	500	4,5	5,0	5,4	8	20
C5V1	4,2	4,7	5,3	400	480	5,0	5,4	5,9	6	20
C5V6	4,8	5,4	6,0	80	400	5,2	5,7	6,3	4	20
C6V2	5,6	6,1	6,6	40	150	5,8	6,3	6,8	3	10
C6V8	6,3	6,7	7,2	30	80	6,4	6,9	7,4	2,5	10
C7V5	6,9	7,4	7,9	30	80	7,0	7,6	8,0	2,5	8
C8V2	7,6	8,1	8,7	40	80	7,7	8,3	8,8	3	8
C9V1	8,4	9,0	9,6	40	100	8,5	9,2	9,7	4	8
C10	9,3	9,9	10,6	50	150	9,4	10,1	10,7	4	10
→ C11	10,2	10,9	11,6	50	150	10,4	11,1	11,8	5	10
→ C12	11,2	11,9	12,7	50	150	11,4	12,1	12,9	5	10
C13	12,3	12,9	14,0	50	170	12,5	13,1	14,2	5	15
C15	13,7	14,9	15,5	50	200	13,9	15,1	15,7	6	20
C16	15,2	15,9	17,0	50	200	15,4	16,1	17,2	6	20
C18	16,7	17,9	19,0	50	225	16,9	18,1	19,2	6	20
C20	18,7	19,9	21,1	60	225	18,9	20,1	21,4	7	20
C22	20,7	21,9	23,2	60	250	20,9	22,1	23,4	7	25
C24	22,7	23,9	25,5	60	250	22,9	24,1	25,7	7	25
	at $I_Z = 0,1\text{ mA}$			at $I_Z = 0,5\text{ mA}$		at $I_Z = 10\text{ mA}$			at $I_Z = 10\text{ mA}$	
	min.	nom.	max.	typ.	max.	min.	nom.	max.	typ.	max.
C27	25,0	26,9	28,9	65	300	25,2	27,1	29,3	10	45
C30	27,8	29,9	32,0	70	300	28,1	30,1	32,4	15	50
C33	30,8	32,9	35,0	75	325	31,1	33,1	35,4	20	55
C36	33,8	35,9	38,0	80	350	34,1	36,1	38,4	25	60
C39	36,7	38,9	41,0	80	350	37,1	39,1	41,5	25	70
C43	39,7	42,9	46,0	85	375	40,1	43,1	46,5	25	80
C47	43,7	46,8	50,0	85	375	44,1	47,1	50,5	30	90
C51	47,6	50,8	54,0	90	400	48,1	51,1	54,6	35	100
C56	51,5	55,7	60,0	100	425	52,1	56,1	60,8	45	110
C62	57,4	61,7	66,0	120	450	58,2	62,1	67,0	60	120
C68	63,4	67,7	72,0	150	475	64,2	68,2	73,2	75	130
C75	69,4	74,7	79,0	170	500	70,3	75,3	80,2	90	140



CHARACTERISTICS (continued)

$T_j = 25\text{ }^\circ\text{C}$

±2% tolerance range.

BZX79-...	Working voltage		Differential resistance		Temperature coefficient	Diode capacitance	
	V_Z (V)		r_{diff} (Ω)		S_Z (mV/ $^\circ\text{C}$)	C_d (pF); $f = 1\text{ MHz}$	
	at $I_Z = 5\text{ mA}$		at $I_Z = 5\text{ mA}$		at $I_Z = 5\text{ mA}$	$V_R = 0$	
	min.	max.	typ.	max.	typ.	typ.	max.
B4V7	4,61	4,79	50	80	-1,4	130	180
B5V1	5,00	5,20	40	60	-0,8	110	160
B5V6	5,49	5,71	15	40	1,2	95	140
B6V2	6,08	6,32	6	10	2,3	90	130
B6V8	6,66	6,94	6	15	3,0	85	110
B7V5	7,35	7,65	6	15	4,0	80	100
B8V2	8,04	8,36	6	15	4,6	75	95
B9V1	8,92	9,28	6	15	5,5	70	90
B10	9,80	10,20	8	20	6,4	70	90
B11	10,80	11,20	10	20	7,4	65	85
B12	11,80	12,20	10	25	8,4	65	85
B13	12,70	13,30	10	30	9,4	60	80
B15	14,70	15,30	10	30	11,4	55	75
B16	15,70	16,30	10	40	12,4	52	75
B18	17,60	18,40	10	45	14,4	47	70
B20	19,60	20,40	15	55	16,4	36	60
B22	21,60	22,40	20	55	18,4	34	60
B24	23,50	24,50	25	70	20,4	33	55
	at $I_Z = 2\text{ mA}$		at $I_Z = 2\text{ mA}$		at $I_Z = 2\text{ mA}$		
	min.	max.	max.		typ.	typ.	max.
B27	26,50	27,50	80		23,5	30	50
B30	29,40	30,60	80		26,0	27	50
B33	32,30	33,70	80		29,0	25	45
B36	35,30	36,70	90		31,0	23	45
B39	38,20	39,80	130		34,0	21	45
B43	42,10	43,90	150		37,0	21	40
B47	46,10	47,90	170		40,0	19	40
B51	50,00	52,00	180		44,0	19	40
B56	54,90	57,10	200		47,0	18	40
B62	60,80	63,20	215		51,0	17	35
B68	66,60	69,40	240		56,0	17	35
B75	73,50	76,50	255		60,0	16,5	35

Note

Typical values on differential resistance for types B27 to B75 and min. and max. values on temperature coefficient will be supplied on request.

**BZX79
SERIES**

CHARACTERISTICS (continued)

$T_j = 25\text{ }^\circ\text{C}$

$\pm 2\%$ tolerance range.

BZX79-...	Working voltage		Differential resistance		Working voltage		Differential resistance	
	V_Z (V)		r_{diff} (Ω)		V_Z (V)		r_{diff} (Ω)	
	at $I_Z = 1\text{ mA}$		at $I_Z = 1\text{ mA}$		at $I_Z = 20\text{ mA}$		at $I_Z = 20\text{ mA}$	
	nom.	typ.	max.	nom.	typ.	max.	typ.	max.
B4V7	4,2	425	500	5,0	8	20		
B5V1	4,7	400	480	5,4	6	20		
B5V6	5,4	80	400	5,7	4	20		
B6V2	6,1	40	150	6,3	3	10		
B6V8	6,7	30	80	6,9	2,5	10		
B7V5	7,4	30	80	7,6	2,5	8		
B8V2	8,1	40	80	8,3	3	8		
B9V1	9,0	40	100	9,2	4	8		
B10	9,9	50	150	10,1	4	10		
B11	10,9	50	150	11,1	5	10		
B12	11,9	50	150	12,1	5	10		
B13	12,9	50	170	13,1	5	15		
B15	14,9	50	200	15,1	6	20		
B16	15,9	50	200	16,1	6	20		
B18	17,9	50	225	18,1	6	20		
B20	19,9	60	225	20,1	7	20		
B22	21,9	60	250	22,1	7	25		
B24	23,9	60	250	24,1	7	25		

Note

Extended information for types B27 to B75 will be supplied on request.

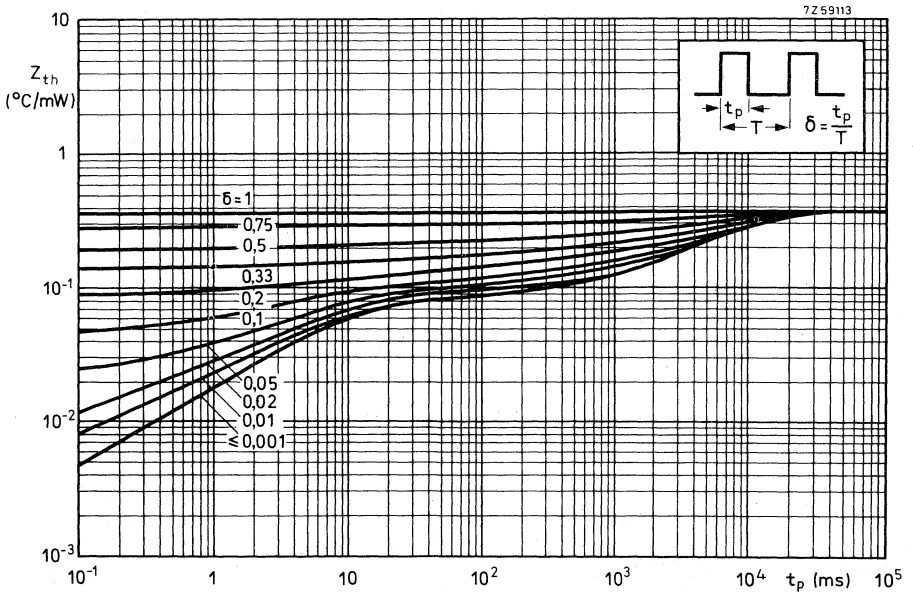
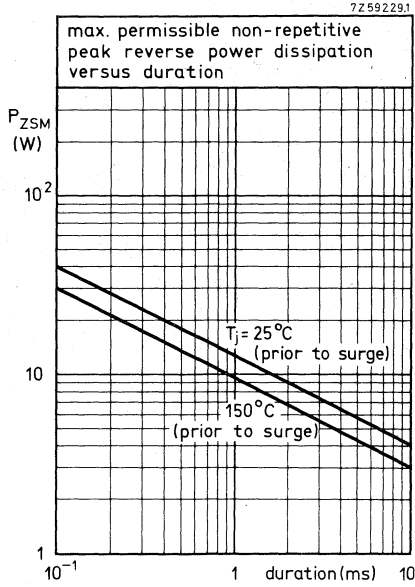

BZX79
SERIES

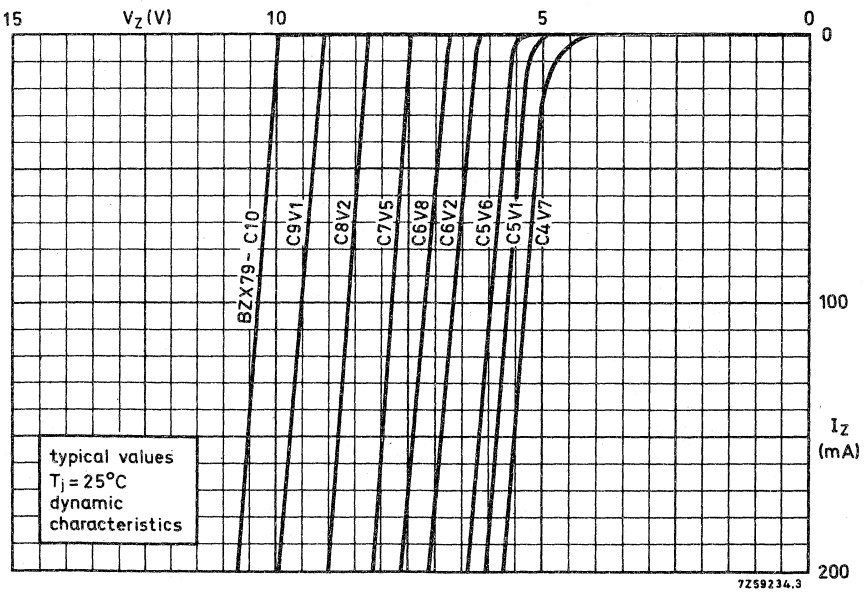
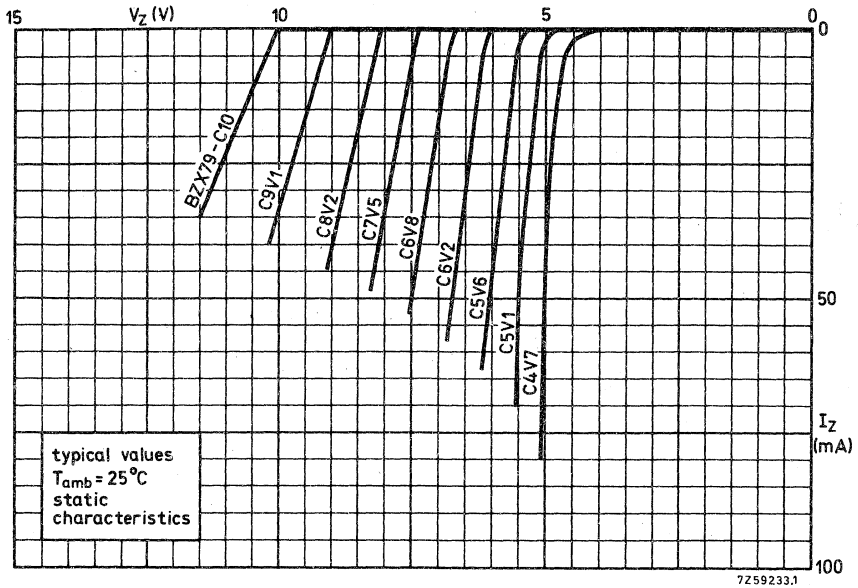

BZX79 SERIES

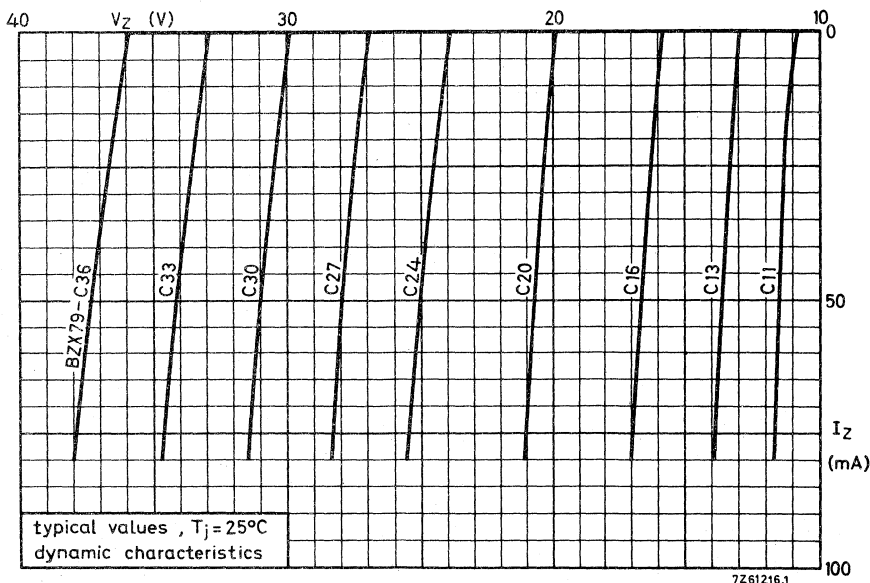
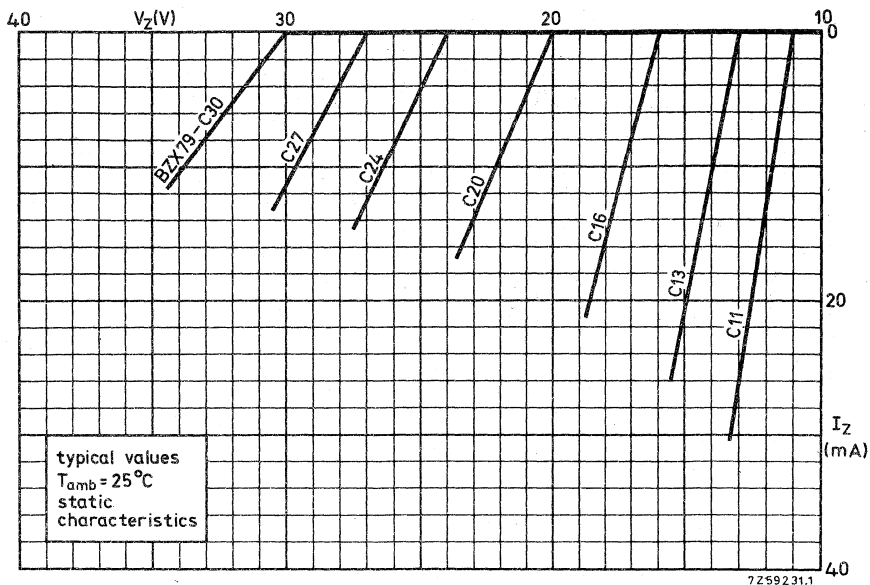

BZX79 SERIES

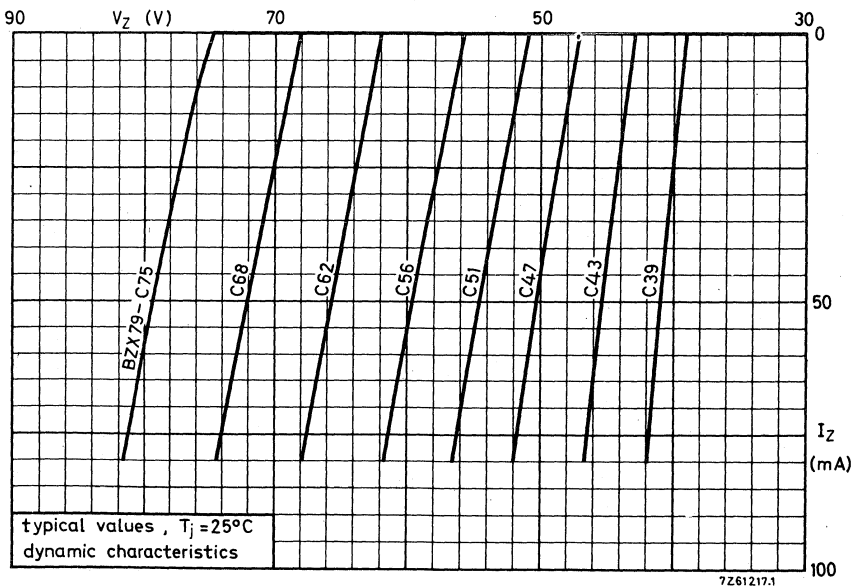
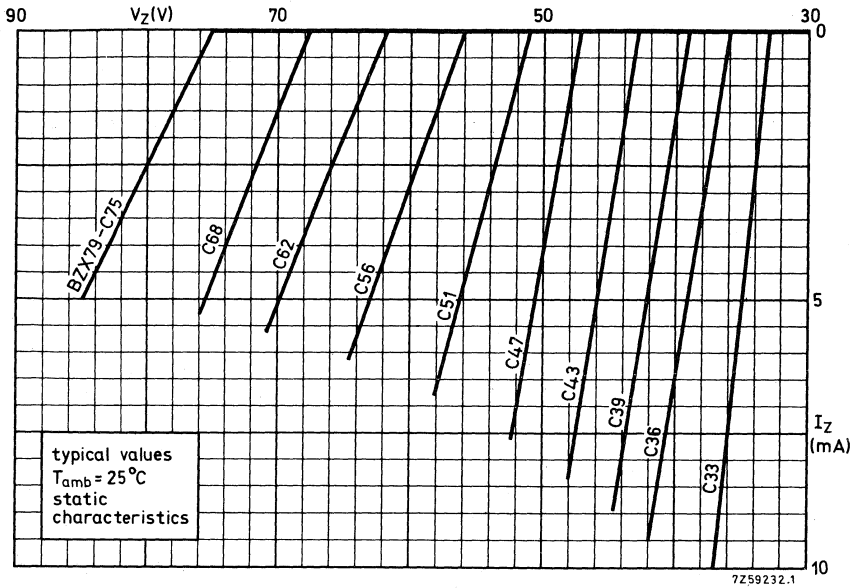

BZX79 SERIES

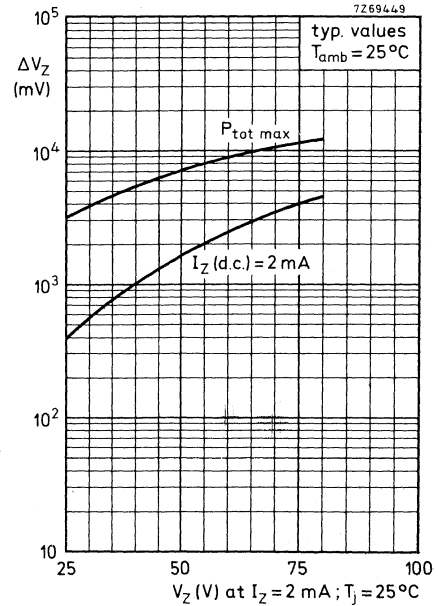
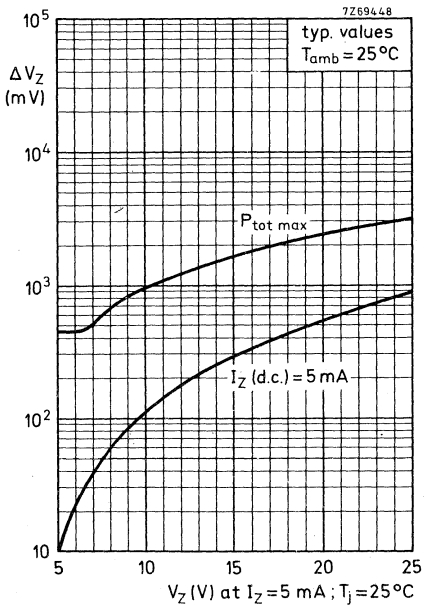
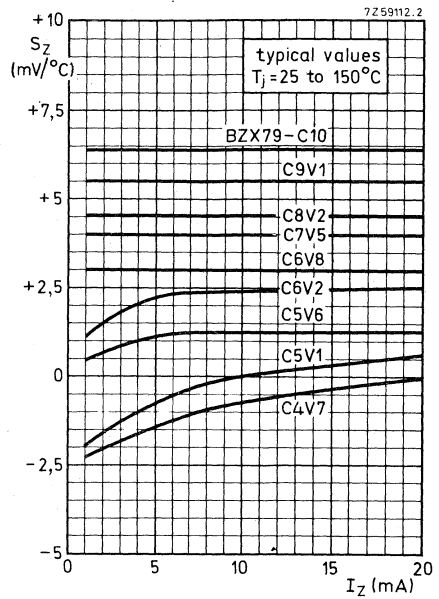
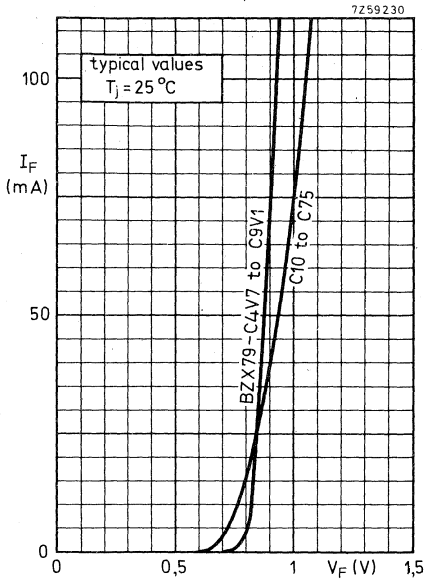

**BZX79
SERIES**

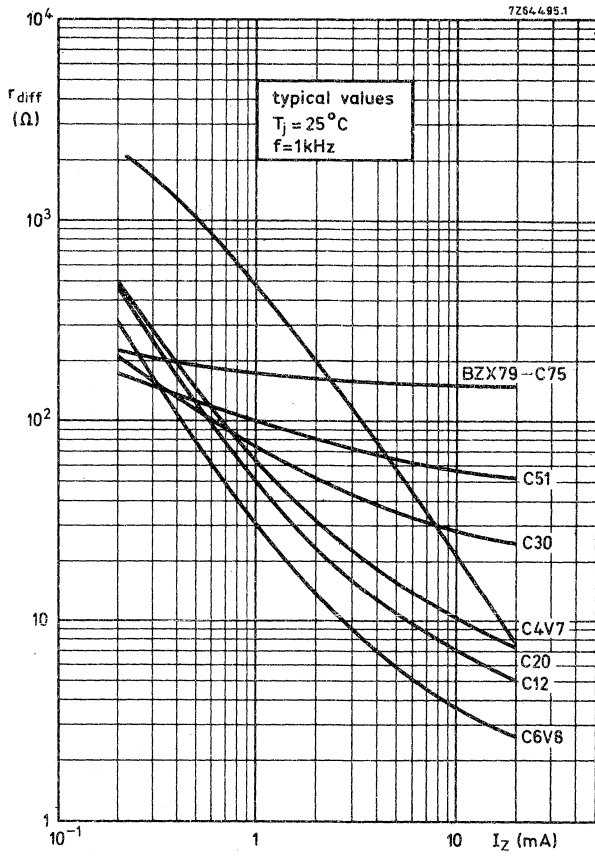

SILICON PLANAR VOLTAGE REGULATOR DIODES

Silicon planar voltage regulator diodes in hermetically sealed glass envelopes intended for stabilization purposes.
The series covers the normalized range of nominal working voltages from 5,1 V to 75 V with a tolerance of $\pm 5\%$ (international standard E24).

QUICK REFERENCE DATA			
Working voltage range	V_Z	nom.	5,1 to 75 V
Working voltage tolerance			E24($\pm 5\%$)
Total power dissipation	P_{tot}	max.	2,0 W
Junction temperature	T_j	max.	200 °C

MECHANICAL DATA

Dimensions in mm

SOD-51

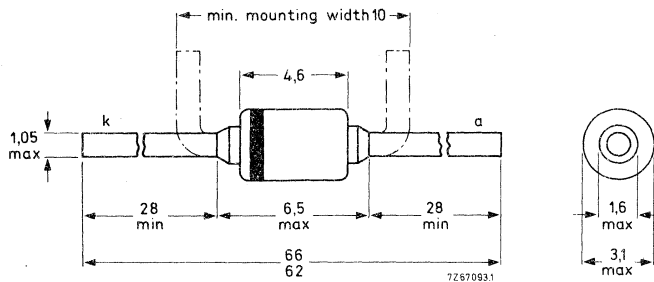

Coloured band indicates cathode

RATINGS Limiting values in accordance with the Absolute Maximum System (IEC 134)

Currents

Working current (d. c.)	I_Z	limited by P_{tot} max
Repetitive peak working current	I_{ZRM}	limited by P_{ZRMmax}
Repetitive peak forward current	I_{FRM}	max. 400 mA

Power dissipation (see also graph on page 4)

Total power dissipation	P_{tot}	max. 1,3 W 1) max. 2,0 W 2)
Repetitive peak reverse power dissipation up to $T_{amb} = 25\text{ }^\circ\text{C}$; $t_p = 100\text{ }\mu\text{s}$; $\delta = 0,001$	P_{ZRM}	max. 7,5 W
Non-repetitive peak reverse power dissipation up to $T_{amb} = 25\text{ }^\circ\text{C}$; $t_p = 100\text{ }\mu\text{s}$	P_{ZSM}	max. 100 W

Temperatures

Storage temperature	T_{stg}	-65 to +200 $^\circ\text{C}$
Junction temperature	T_j	max. 200 $^\circ\text{C}$

THERMAL RESISTANCE (see also graph on page 4)

From junction to ambient when soldered to strip with a max. lead length of 28 mm	$R_{th\ j-a}$	= 134 $^\circ\text{C}/\text{W}$
--	---------------	---------------------------------

CHARACTERISTICS

$T_j = 25\text{ }^\circ\text{C}$

<u>Forward voltage</u> at $I_F = 0,2\text{ A}$	V_F	< 1 V
--	-------	-------

<u>Reverse current</u> at	BZX87-C5V1 C5V6	C6V2	C6V8	C7V5 C8V2	C9V1	C10 to C75	
$V_R = 2\text{ V}$	$I_R < 10$	5	-	-	-	-	μA
$V_R = 3\text{ V}$	$I_R < -$	-	3	1	-	-	μA
$V_R = 5\text{ V}$	$I_R < -$	-	-	-	1	-	μA
$V_R = \frac{2}{3} V_{Znom}$	$I_R < -$	-	-	-	-	1	μA

1) Measured in still air up to $T_{amb} = 25\text{ }^\circ\text{C}$ and mounted to solder tags at maximum lead length.

2) If the temperature of the leads at 10 mm from the body is kept at $25\text{ }^\circ\text{C}$.

CHARACTERISTICS (continued)

$T_j = 25\text{ }^\circ\text{C}$

	Working voltage V_Z (V)		Temperature coefficient S_Z (mV/°C)	Differential resistance r_{diff} (Ω)	Diode capacitance C_d (pF) at $f = 1\text{ MHz}$
	at $I_Z = 50\text{ mA}$		at $I_Z = 50\text{ mA}$	at $I_Z = 50\text{ mA}$	$V_R = 0$
BZX87-....	min.	max.	typ.	max.	typ.
C5V1	4,8	5,4	+0,2	10	220
C5V6	5,2	6,0	+1,4	5	200
C6V2	5,8	6,6	+2	3	350
	at $I_Z = 20\text{ mA}$		at $I_Z = 20\text{ mA}$	at $I_Z = 20\text{ mA}$	
C6V8	6,4	7,2	2,5	3	310
C7V5	7,0	7,9	3,0	3	280
C8V2	7,7	8,7	3,5	4	250
C9V1	8,5	9,6	4,5	4	225
C10	9,4	10,6	5,5	5	200
C11	10,4	11,6	6,2	5	180
C12	11,4	12,7	7,5	6	165
C13	12,4	14,1	8,5	7	200
C15	13,8	15,6	10,5	10	170
	at $I_Z = 10\text{ mA}$		at $I_Z = 10\text{ mA}$	at $I_Z = 10\text{ mA}$	
C16	15,3	17,1	12	10	160
C18	16,8	19,1	14	15	140
C20	18,8	21,2	16	15	120
C22	20,8	23,3	18	20	113
C24	22,8	25,6	20	20	108
C27	25,1	28,9	23	25	100
C30	28	32	26	25	97
C33	31	35	30	30	85
C36	34	38	33	35	80
	at $I_Z = 5\text{ mA}$		at $I_Z = 5\text{ mA}$	at $I_Z = 5\text{ mA}$	
C39	37	41	36	40	74
C43	40	46	40	50	69
C47	44	50	44	60	64
C51	48	54	48	70	60
C56	52	60	53	80	56
C62	58	66	60	90	52
C68	64	72	67	110	50
C75	70	79	73	125	48

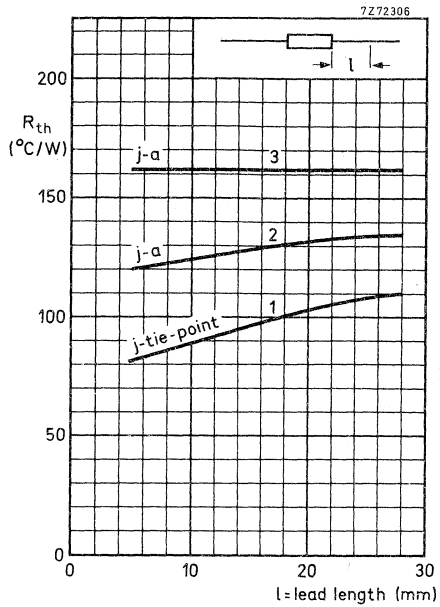
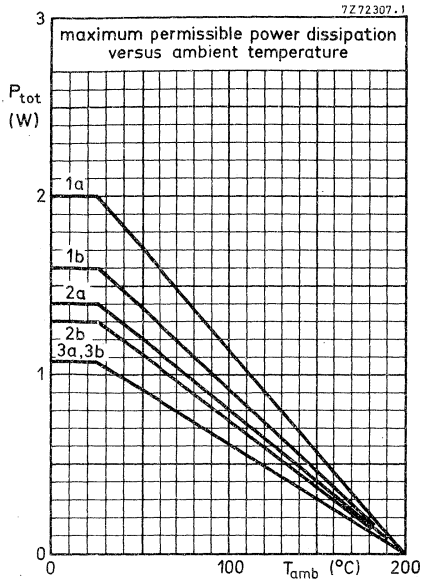

MOUNTING METHODS

- 1. to tie-points
 - 2. to solder tags
 - 3. on a printed-circuit board
- a. lead length = 10 mm
 - b. at maximum lead length

VOLTAGE REGULATOR DIODES

Silicon diodes in all-glass DO-7 envelope for use as low current voltage stabilizers or voltage references.

The series consists of 24 types with nominal working voltages ranging from 3,3V to 30V with a tolerance of $\pm 5\%$.

QUICK REFERENCE DATA			
Working voltage range	V_Z	nom. 3,3 to 30	V
Working voltage tolerance			$\pm 5\%$
Repetitive peak working current	I_{ZRM}	max. 250	mA
Total power dissipation up to $T_{amb} = 50^\circ\text{C}$	P_{tot}	max. 400	mW
Non-repetitive peak reverse power dissipation $T_j = 150^\circ\text{C}; t = 100\ \mu\text{s}$	P_{ZSM}	max. 15	W
Operating junction temperature	T_j	max. 200	$^\circ\text{C}$
Thermal resistance from junction to ambient in free air	$R_{th\ j-a}$	= 0,37	$^\circ\text{C}/\text{mW}$

MECHANICAL DATA

Dimensions in mm

DO-7

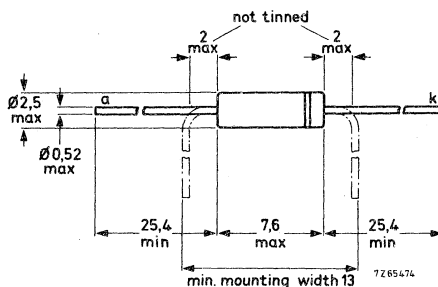

Cathode indicated by coloured band

BZY88
SERIES

RATINGS Limiting values in accordance with the Absolute Maximum System (IEC134)

Currents

Forward current (d. c.)	I_F	max.	250	mA
Repetitive peak forward current	I_{FRM}	max.	250	mA
Repetitive peak working current	I_{ZRM}	max.	250	mA

Power dissipation

Total power dissipation up to $T_{amb} = 50\text{ }^\circ\text{C}$	P_{tot}	max.	400	mW
Non-repetitive peak reverse power dissipation $T_j = 150\text{ }^\circ\text{C}; t = 100\text{ }\mu\text{s}$	P_{ZSM}	max.	15	W

Temperatures

Storage temperature	T_{stg}	-65 to +175	$^\circ\text{C}$
Operating junction temperature	T_j	max.	200 $^\circ\text{C}$

THERMAL RESISTANCE

From junction to ambient in free air	$R_{th\ j-a}$	=	0,37	$^\circ\text{C}/\text{mW}$
--------------------------------------	---------------	---	------	----------------------------



BZY88 SERIES

CHARACTERISTICS

$T_j = 25\text{ }^\circ\text{C}$

Forward voltage

$I_F = 10\text{ mA}$

$V_F < 0.9\text{ V}$

BZY88-...	Working voltage V_Z at $I_Z = 1\text{ mA}$			Temperature coefficient S_Z at $I_Z = 1\text{ mA}$			Differential resistance r_{diff} at $I_Z = 1\text{ mA}$		
	min.	nom.	max.	min.	typ.	max.	min.	typ.	max.
C3V3	2.4	2.75	3.0 V	-4.5	-1.9	-0.5 mV/°C	380	410	440 Ω
C3V6	2.7	3.0	3.3 V	-4.5	-2.05	-0.5 mV/°C	380	410	430 Ω
C3V9	3.0	3.3	3.6 V	-3.5	-2.4	-0.5 mV/°C	380	410	430 Ω
C4V3	3.3	3.6	3.9 V	-2.7	-2.25	-0.5 mV/°C	340	410	430 Ω
C4V7	3.7	4.1	4.3 V	-2.5	-2.0	-0.3 mV/°C	360	390	420 Ω
C5V1	4.3	4.65	5.0 V	-2.1	-1.9	-0.3 mV/°C	300	340	370 Ω
C5V6	4.8	5.3	5.7 V	-1.8	-1.4	0 mV/°C	160	310	350 Ω
C6V2	5.7	5.9	6.5 V	0	+1.6	+3.0 mV/°C	10	100	250 Ω
C6V8	6.3	6.7	6.9 V	+2	+3.2	+3.7 mV/°C	5.0	15	70 Ω
C7V5	7.0	7.45	7.8 V	+3	+4.2	+5.9 mV/°C	4.0	8.6	20 Ω
C8V2	7.8	8.1	8.5 V	+4.3	+5.0	+6.0 mV/°C	4.0	10	20 Ω
C9V1	8.55	9.0	9.5 V	+4.5	+6.0	+7.0 mV/°C	7.0	12	24 Ω
C10	9.3	9.9	10.5 V	+6.0	+6.6	+7.0 mV/°C	5.0	20	50 Ω
C11	10.3	10.9	11.5 V	+7.1	+8.3	+9.0 mV/°C	5.0	25	70 Ω
C12	11.3	11.9	12.5 V	+7.6	+8.7	+9.2 mV/°C	10	25	80 Ω
C13	12.3	12.9	13.0 V	+9.1	+10.1	+11.1 mV/°C	10	25	90 Ω
C15	13.8	14.9	15.5 V	+11	+12.5	+13 mV/°C	19	35	95 Ω
C16	15.3	15.8	16.9 V	+12	+13	+14 mV/°C	20	45	100 Ω
C18	16.7	17.8	18.9 V	+14	+15	+16.5 mV/°C	20	50	120 Ω
C20	18.7	19.8	21.0 V	+16	+17	+18.5 mV/°C	20	60	140 Ω
C22	20.6	21.8	23.1 V	+17	+19	+21 mV/°C	25	70	150 Ω
C24	22.5	23.8	25.7 V	+19	+21	+23 mV/°C	30	85	200 Ω
C27	24.7	26.6	28.5 V	+21	+22.5	+25 mV/°C	35	90	300 Ω
C30	27.5	29.5	31.5 V	+22	+24	+29 mV/°C	50	180	350 Ω

BZY88 SERIES

CHARACTERISTICS (continued)

$T_j = 25^\circ\text{C}$

BZY88-...	Working voltage V_Z at $I_Z = 5\text{ mA}$			Temperature coefficient S_Z at $I_Z = 5\text{ mA}$			Differential resistance r_{diff} at $I_Z = 5\text{ mA}$		
	min.	nom.	max.	min.	typ.	max.	min.	typ.	max.
C3V3	3.1	3.3	3.5 V	-4.0	-2.3	-0.5 mV/°C	70	83.5	110 Ω
C3V6	3.4	3.6	3.8 V	-3.5	-2.0	-0.5 mV/°C	65	76	105 Ω
C3V9	3.7	3.9	4.1 V	-2.5	-2.05	-0.5 mV/°C	60	76	100 Ω
C4V3	4.0	4.3	4.5 V	-2.5	-1.8	-0.5 mV/°C	55	70	90 Ω
C4V7	4.4	4.7	5.0 V	-2.0	-1.55	0 mV/°C	49	62	85 Ω
C5V1	4.8	5.1	5.4 V	-1.75	-1.2	0 mV/°C	34	46	75 Ω
C5V6	5.3	5.6	6.0 V	-1.5	-0.2	+1.0 mV/°C	10	22	55 Ω
C6V2	5.8	6.2	6.6 V	+0.5	+2.0	+3.5 mV/°C	1.0	7.0	27 Ω
C6V8	6.4	6.8	7.2 V	+2.3	+3.2	+3.8 mV/°C	0.5	3.0	15 Ω
C7V5	7.1	7.5	7.9 V	+3.1	+4.2	+5.9 mV/°C	0.5	3.0	15 Ω
C8V2	7.8	8.2	8.7 V	+4.2	+5.0	+6.0 mV/°C	0.9	3.5	20 Ω
C9V1	8.6	9.1	9.6 V	+4.8	+6.0	+7.0 mV/°C	1.0	4.75	25 Ω
C10	9.4	10	10.6 V	+6.0	+7.0	+7.5 mV/°C	2.0	5.0	25 Ω
C11	10.4	11	11.6 V	+7.0	+8.7	+9.1 mV/°C	3.0	7.0	25 Ω
C12	11.4	12	12.6 V	+8.5	+9.0	+9.6 mV/°C	4.0	8.0	35 Ω
C13	12.4	13	14.1 V	+10	+10.5	+11.5 mV/°C	4.0	10	35 Ω
C15	13.9	15	15.6 V	+12	+12.5	+14 mV/°C	4.0	15	35 Ω
C16	15.4	16	17.1 V	+12	+13	+14 mV/°C	5.0	20	40 Ω
C18	16.9	18	19.1 V	+14	+15	+18 mV/°C	7.0	25	45 Ω
C20	18.9	20	21.2 V	+16	+17	+19 mV/°C	10	30	50 Ω
C22	20.8	22	23.3 V	+17	+19	+21 mV/°C	15	35	60 Ω
C24	22.7	24	25.9 V	+20	+21	+24 mV/°C	20	40	75 Ω
C27	25.1	27	28.9 V	+22	+23.5	+27 mV/°C	25	50	85 Ω
C30	28	30	32 V	+25	+26	+29 mV/°C	30	60	95 Ω

CHARACTERISTICS (continued)

$T_j = 25\text{ }^\circ\text{C}$

BZY88-...	Working voltage V_Z at $I_Z = 20\text{ mA}$			Temperature coefficient S_Z at $I_Z = 20\text{ mA}$			Differential resistance r_{diff} at $I_Z = 20\text{ mA}$		
	min.	nom.	max.	min.	typ.	max.	min.	typ.	max.
C3V3	3.5	4	4.2 V	-3.3	-2.4	-0.5 mV/°C	16.0	19.5	22 Ω
C3V6	3.9	4.2	4.4 V	-2.5	-1.55	-0.5 mV/°C	16	18	20 Ω
C3V9	4.2	4.45	4.65 V	-2.4	-1.55	-0.5 mV/°C	14	16	18 Ω
C4V3	4.45	4.7	4.95 V	-2.0	-1.5	-0.5 mV/°C	13	15	17 Ω
C4V7	4.9	5.1	5.3 V	-1.5	-0.85	0 mV/°C	12	15	17 Ω
C5V1	5.1	5.35	5.7 V	-1.5	-0.8	0 mV/°C	4.0	7.0	11 Ω
C5V6	5.45	5.75	6.1 V	-1.0	+1.0	+3.0 mV/°C	1.5	4.0	8.0 Ω
C6V2	5.95	6.4	6.7 V	+1.0	+2.2	+4.0 mV/°C	0.8	1.4	3.1 Ω
C6V8	6.6	6.9	7.25 V	+2.8	+3.2	+3.8 mV/°C	0.7	1.3	3.0 Ω
C7V5	7.2	7.65	7.95 V	+2.5	+4.2	+5.9 mV/°C	0.5	1.6	5.0 Ω
C8V2	7.9	8.4	8.75 V	+4.0	+5.0	+6.0 mV/°C	0.9	1.8	6.0 Ω
C9V1	8.7	9.4	9.7 V	+5.0	+6.0	+7.0 mV/°C	1.0	1.85	7.0 Ω
C10	9.5	10.1	10.8 V	+7.0	+7.3	+7.5 mV/°C	1.0	2.0	8.0 Ω
C11	10.5	11.1	11.8 V	+8.5	+9.1	+9.5 mV/°C	1.0	3.0	10 Ω
C12	11.6	12.2	12.8 V	+8.9	+9.6	+10.3 mV/°C	2.0	3.5	25 Ω
C13	12.6	13.2	14.3 V	+11	+11.5	+12.5 mV/°C	2.0	4.5	25 Ω
C15	14.1	15.3	15.9 V	+12	+13.5	+14.5 mV/°C	2.0	6.0	25 Ω
C16	15.6	16.3	17.4 V	+13	+14	+15 mV/°C	5.0	10	30 Ω
C18	17.2	18.4	19.6 V	+15	+16	+18 mV/°C	5.0	12	30 Ω
C20	19.3	20.5	21.9 V	+17.5	+18.5	+20.5 mV/°C	5.0	15	35 Ω
C22	21.3	22.6	24.1 V	+19	+20.5	+22.5 mV/°C	10	18	35 Ω
C24	23.3	24.7	26.7 V	+20	+23	+25 mV/°C	10	20	40 Ω
C27	25.8	28.1	30.1 V	+23	+25.5	+28 mV/°C	10	25	45 Ω
C30	29.0	31.3	33.4 V	+25	+28	+32 mV/°C	10	35	50 Ω

BZY88
SERIES

CHARACTERISTICS (continued)

$T_j = 25\text{ }^\circ\text{C}$

BZY88-...	Diode capacitance C_d at $V_R = 3\text{ V}$ (typ.)	Reverse current I_R		
		at $V_R =$	typ.	max.
C3V3	395 pF	1 V	0.54	3.0 μA
C3V6	370 pF	1 V	0.25	3.0 μA
C3V9	335 pF	1 V	0.11	3.0 μA
C4V3	270 pF	1 V	0.1	3.0 μA
C4V7	290 pF	2 V	0.25	3.0 μA
C5V1	275 pF	2 V	0.15	1.0 μA
C5V6	260 pF	2 V	0.6	1.0 μA
C6V2	240 pF	2 V	0.1	1.0 μA
C6V8	220 pF	3 V	0.025	1.0 μA
C7V5	190 pF	3 V	15	500 nA
C8V2	150 pF	3 V	11	400 nA
C9V1	140 pF	5 V	8	400 nA
C10	110 pF	7 V	-	2.5 μA
C11	90 pF	7 V	-	2.5 μA
C12	80 pF	8 V	-	2.5 μA
C13	65 pF	9 V	-	2.5 μA
C15	60 pF	10 V	-	2.5 μA
C16	55 pF	10 V	-	2.5 μA
C18	50 pF	13 V	-	2.5 μA
C20	45 pF	14 V	-	2.5 μA
C22	43 pF	15 V	-	2.5 μA
C24	42 pF	17 V	-	2.5 μA
C27	40 pF	19 V	-	2.5 μA
C30	35 pF	21 V	-	2.5 μA



OPERATING NOTES

1. Dissipation and heatsink considerations

a. Steady-state conditions

The maximum allowable steady-state dissipation $P_S \text{ max}$ is given by the relationship

$$P_S \text{ max} = \frac{T_{j \text{ max}} - T_{\text{amb}}}{R_{th \text{ j-a}}}$$

where $T_{j \text{ max}}$ is the maximum permissible operating junction temperature,
 T_{amb} is the ambient temperature,
 $R_{th \text{ j-a}}$ is the total thermal resistance from junction to ambient

b. Pulse conditions (see fig. below)

The maximum allowable additional pulse power $P_m \text{ max}$ is given by the formula

$$P_m \text{ max} = \frac{(T_{j \text{ max}} - T_{\text{amb}}) - (P_S \cdot R_{th \text{ j-a}})}{Z_{th}}$$

where P_S is the steady-state dissipation, excluding that in the pulses,

Z_{th} is the effective transient thermal resistance of the device from junction to ambient. It is a function of the pulse duration t and duty cycle δ (see page 11, lower figure).

δ is the duty cycle and is equal to the pulse duration t divided by the period duration T .

The steady-state power P_S when biased in the zener direction at a given zener current can be found from page 15, upper figure. With the additional pulsed power dissipation $P_m \text{ max}$ calculated from the above expression, the total repetitive peak zener power dissipation $P_{ZRM} = P_S + P_m \text{ max}$. From page 15, upper figure the corresponding maximum repetitive peak zener current at P_{ZRM} can now be read. This repetitive peak zener current is subject to the absolute maximum rating. For pulse durations longer than the temperature stabilization time of the diode t_{stab} , the maximum allowable repetitive peak dissipation P_{ZRM} is equal to the maximum steady-state power $P_S \text{ max}$. The temperature stabilization time for the BZY88 series is 100 s (see page 11, lower figure).

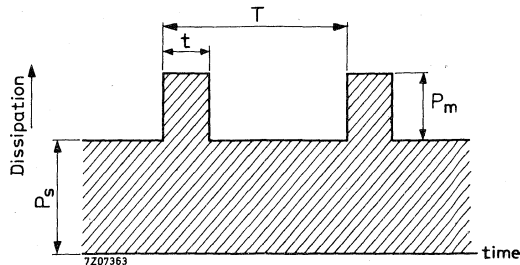

OPERATING NOTES (continued)

Example

The following example illustrates how to calculate the maximum permissible repetitive peak zener current of a BZY88-C7V5 zener diode mounted in freeair at a maximum ambient temperature of 60 °C. The steady-state zener current is 10 mA, the duty cycle $\delta = 0.1$ and the pulse duration $t = 1$ ms.

The steady-state dissipation P_S at a zener current of 10 mA (from page 15, upper figure) = 76 mW.

The thermal resistance from junction to ambient $R_{th\ j-a} = 0.31$ °C/mW.

The thermal impedance Z_{th} with a duty cycle $\delta = 0.1$ and a pulse duration $t = 1$ ms (from page 11, lower figure).

$$Z_{th} = 41.5 \text{ °C/W}$$

The maximum additional pulse power dissipation

$$P_{m\ max} = \frac{(T_{j\ max} - T_{amb}) - P_S \cdot R_{th\ j-a}}{Z_{th}}$$

If $P_S = 76$ mW, $Z_{th} = 41.5$ °C/W,

$$P_{m\ max} = \frac{(175-60) - (0.076 \times 310)}{41.5} = 2.2 \text{ W}$$

therefore, the total repetitive peak power dissipation,

$$P_{ZRM} = 0.076 + 2.2 = 2.28 \text{ W}$$

From page 15, upper figure, the corresponding repetitive peak zener current is 250 mA. This is within the rating of the BZY88-C7V5 and is therefore permissible.

2. Zener characteristics

The basic characteristic of a zener diode is the dynamic zener characteristic, that is, the variation of zener voltage when a current pulse is applied in the reverse direction. The slope of this characteristic is r_z . Typical dynamic characteristics at $T_j = 25$ and 150 °C are given on pages 12 and 13 for each type of diode. Because of the temperature sensitivity of the zener characteristics, the dynamic characteristics at any other operating temperature will be displaced from those at $T_j = 25$ °C by a voltage corresponding to $S_Z \times (T_n - 25)$ °C, where S_Z is the temperature coefficient of the diode and T_n is a nominal operating temperature. This is illustrated below.

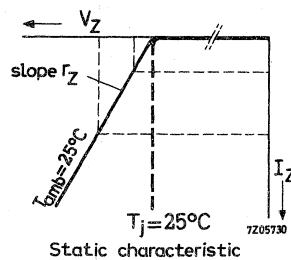
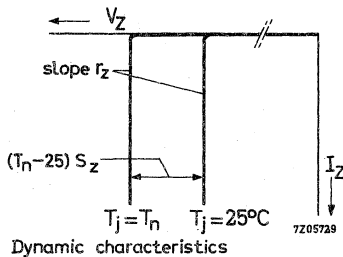

OPERATING NOTES (continued)

The static characteristic of the diode is obtained by connecting the steady-state zener voltages at various direct zener currents and may, therefore, be used to determine the operating point at any zener current. This is shown above. The slope of the static characteristic will depend on

- (1) the differential resistance, r_z
- (2) the rise in junction temperature due to internal dissipation and the thermal resistance from junction to ambient, $V_Z \cdot I_Z \cdot R_{th\ j-a}$
- (3) the temperature coefficient of the diode, S_Z

From the above, the static slope resistance r_Z is found to be

$$r_Z = r_z + V_Z \cdot R_{th\ j-a} \cdot S_Z$$

where r_z is the differential resistance, V_Z is the steady-state zener voltage and is equal to

$$\frac{V_Z'}{1 - I_Z \cdot R_{th\ j-a} \cdot S_Z}$$

V_Z' being the zener voltage at $T_j = T_n$ at the working current I_Z .

The position of this static characteristic in relation to the dynamic characteristic at $T_j = 25^\circ\text{C}$ is dependent on the ambient temperature and the temperature coefficient, the low-current voltage being displaced by

$$S_Z \times (T_n - 25)^\circ\text{C}$$

from the low current voltage, V_{ZO} on the dynamic characteristic at $T_j = 25^\circ\text{C}$ (See figure below)

Example for positive S_Z

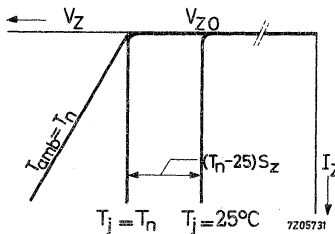

OPERATING NOTES (continued)

Next figure shows typical dynamic characteristics at $T_j = 25, 150$ and a nominal temperature, T_n °C. It also shows static characteristics at ambient temperatures of 25 and T_n °C.

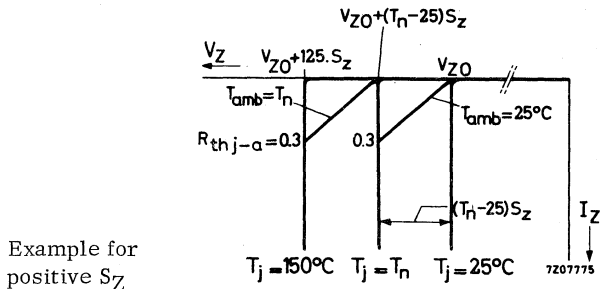

Typical static characteristics for each type of diode are given on page 14. These curves were obtained with the device mounted in free air at an ambient temperature of 25 °C.

The slope resistance for pulse operation can be calculated by incorporating the thermal impedance Z_{th} into the formula for r_Z . Curves of Z_{th} plotted against pulse duration and duty cycle are given in the lower figure on page 11.

3. When using a soldering iron, the diode may be soldered directly into a circuit, but heat conducted to the junction should be kept to a minimum by use of a thermal shunt.
4. Diodes may be dip soldered at a solder temperature of 245 °C for a maximum soldering time of 5 seconds. The case temperature during dip soldering must not at any time exceed the maximum storage temperature. These recommendations apply to a diode with the anode end mounted flush on the board with punched-through holes. For mounting the cathode end onto the board the diode must be spaced 5 mm from the underside of the printed circuit board in the case of punched-through holes or 5 mm from the top of the board for plated-through holes.
5. Care should be taken not to bend the leads nearer than 1.5 mm from the seals.

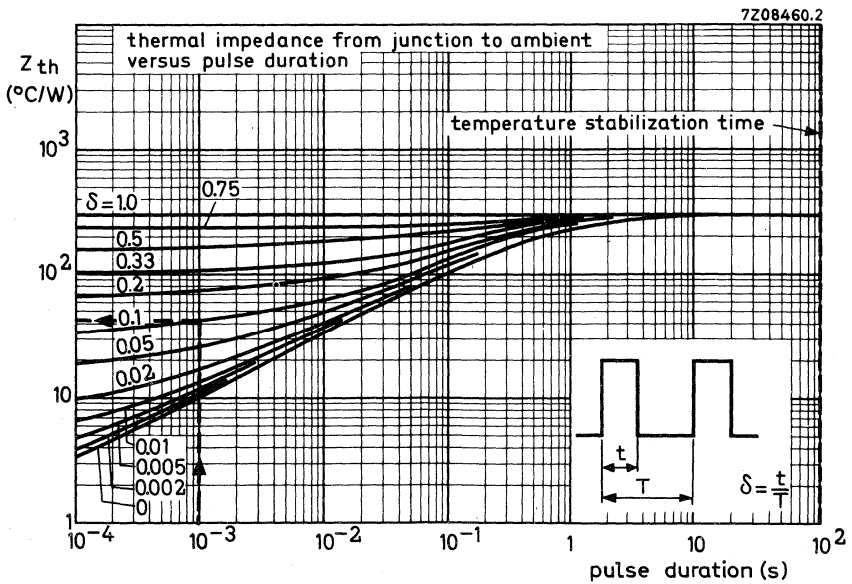
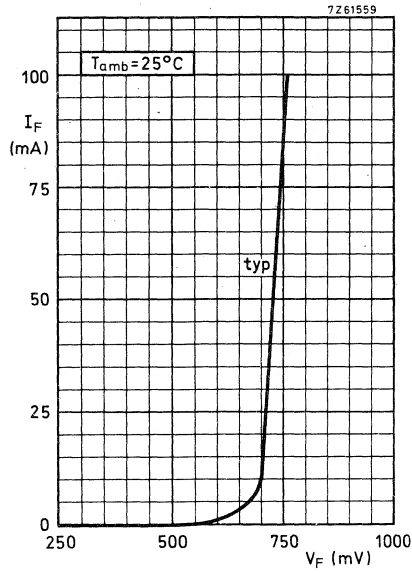

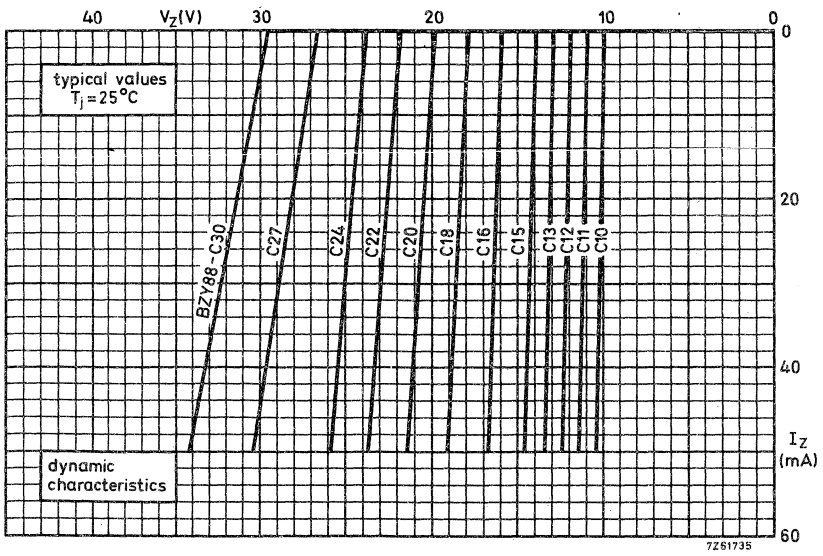
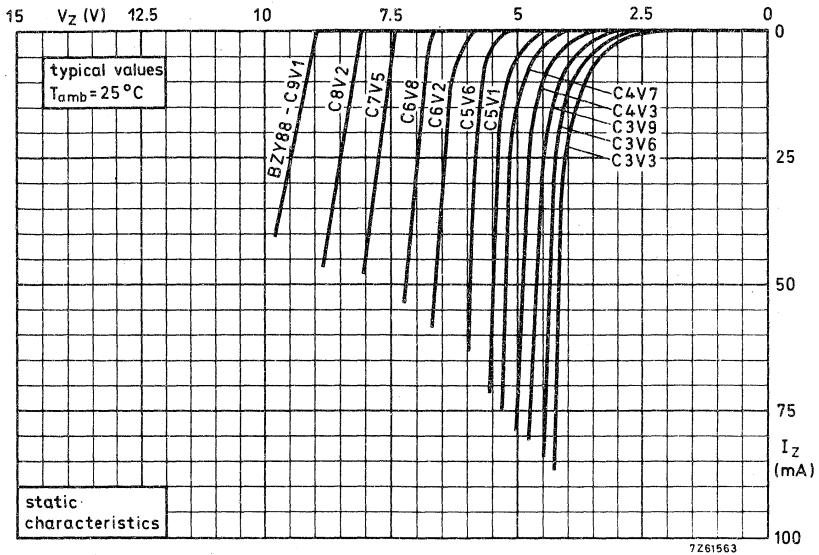

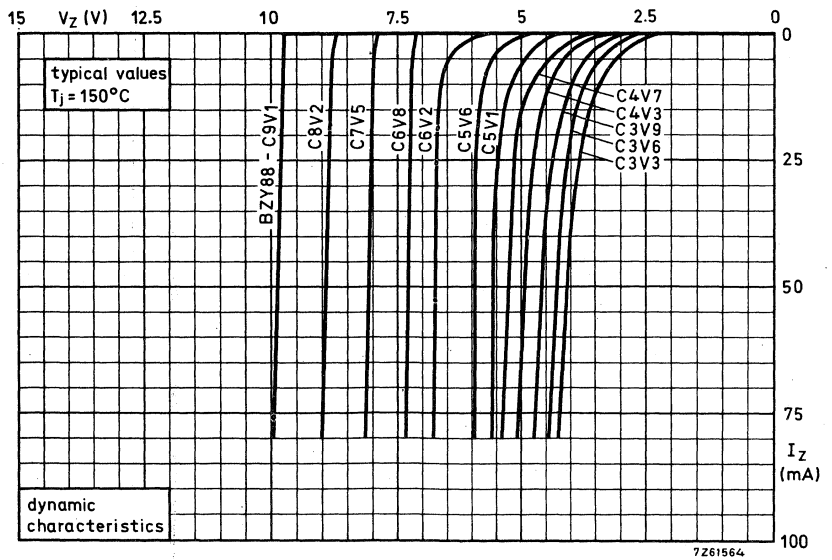
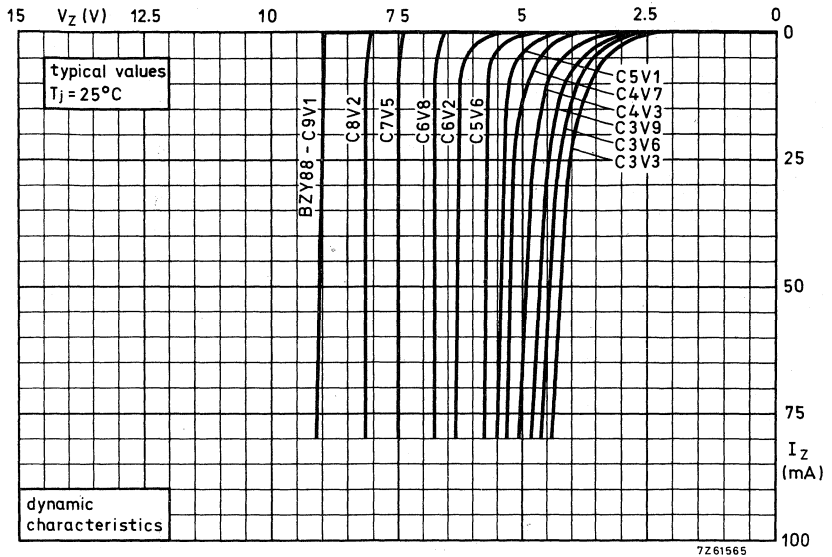

BZY88 SERIES

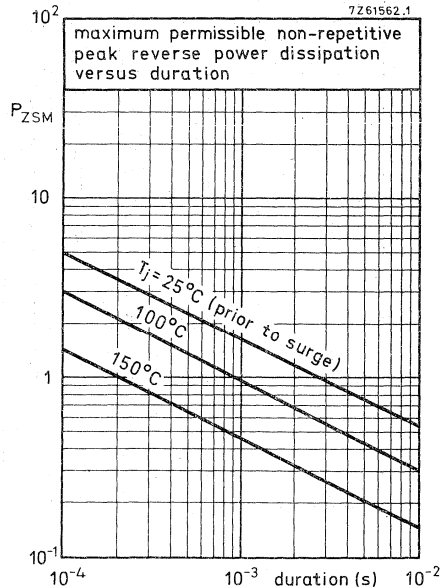
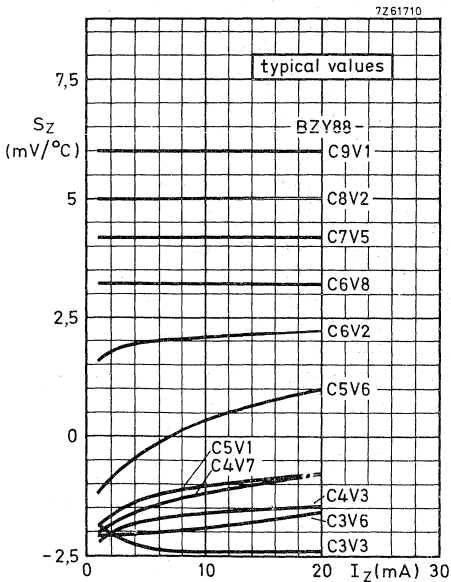
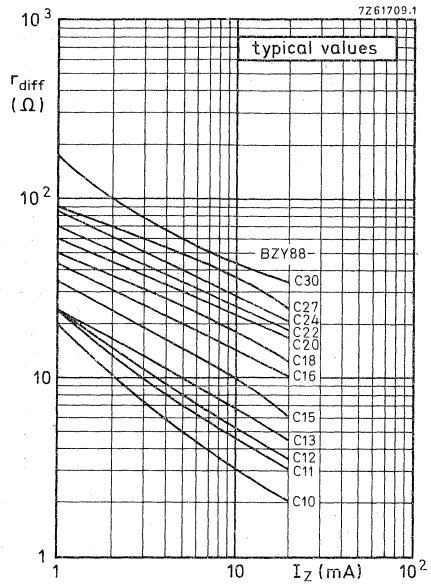
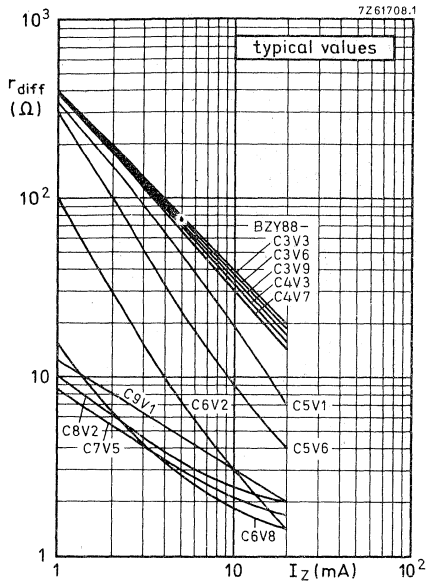

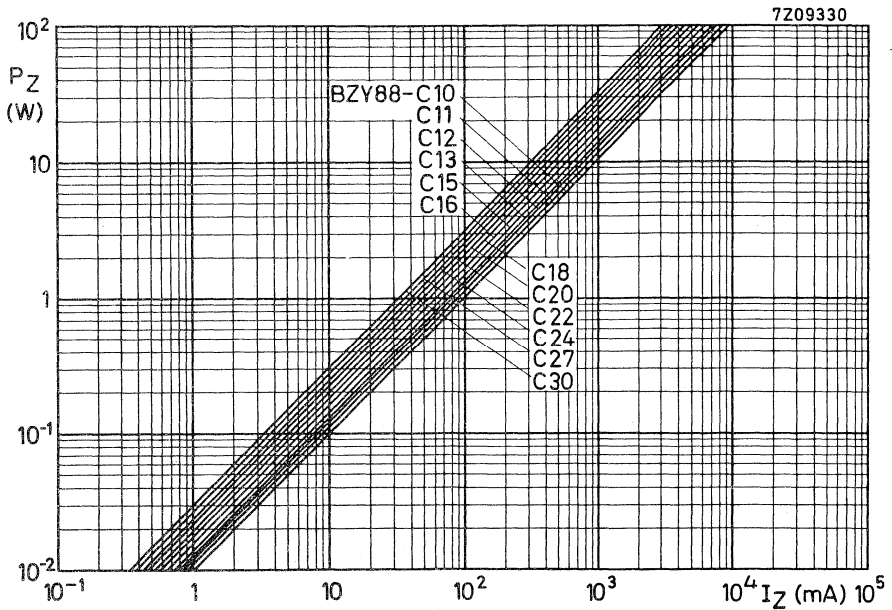
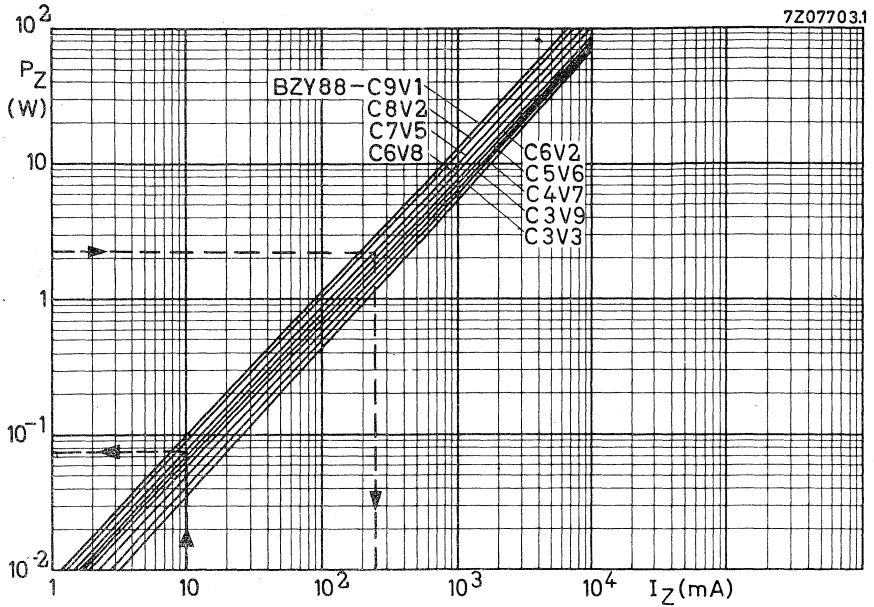

VOLTAGE REGULATOR DIODES

Silicon planar diodes in a DO-35 envelope intended for use as low power voltage stabilizers or voltage references.

The series consists of 29 types with nominal voltages ranging from 5,1 to 75V with tolerances to the international standardized E24 ($\pm 5\%$) range.

QUICK REFERENCE DATA			
Working voltage range (E24; $\pm 5\%$)	V_Z	nom. 5,1 to 75	V
Total power dissipation	P_{tot}	max. 400	mW 1)
		max. 500	mW 2)
Non-repetitive peak reverse power dissipation $t = 100 \mu s; T_j = 150 \text{ }^\circ\text{C}$	P_{ZSM}	max. 30	W
Junction temperature	T_j	max. 200	$^\circ\text{C}$
Thermal resistance from junction to ambient	$R_{th j-a}$	= 0,38	$^\circ\text{C}/\text{mW}$ 3)

- 1) In still air at maximum lead length up to $T_{amb} = 50 \text{ }^\circ\text{C}$.
- 2) If leads are kept at $T_{amb} = 25 \text{ }^\circ\text{C}$ at 8 mm from body.
- 3) Measured in still air at maximum lead length.

MECHANICAL DATA

Dimensions in mm

DO-35

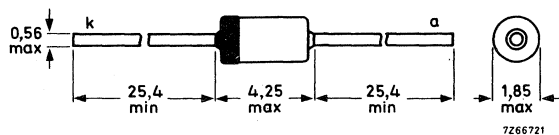

Cathode indicated by coloured band

IN5729B to IN5757B

RATINGS Limiting values in accordance with the Absolute Maximum System (IEC134)

Currents

Steady-state working current at $T_{amb} = 25\text{ }^{\circ}\text{C}$ | Non-repetitive peak working current

IN5729B	I_Z	max.	65	mA	I_{ZSM}	max.	2,90	A
IN5730B	I_Z	max.	60	mA	I_{ZSM}	max.	2,60	A
IN5731B	I_Z	max.	55	mA	I_{ZSM}	max.	2,40	A
IN5732B	I_Z	max.	50	mA	I_{ZSM}	max.	2,30	A
IN5733B	I_Z	max.	45	mA	I_{ZSM}	max.	2,10	A
IN5734B	I_Z	max.	40	mA	I_{ZSM}	max.	1,95	A
IN5735B	I_Z	max.	40	mA	I_{ZSM}	max.	1,80	A
IN5736B	I_Z	max.	35	mA	I_{ZSM}	max.	1,65	A
IN5737B	I_Z	max.	30	mA	I_{ZSM}	max.	1,50	A
IN5738B	I_Z	max.	30	mA	I_{ZSM}	max.	1,40	A
IN5739B	I_Z	max.	25	mA	I_{ZSM}	max.	1,28	A
IN5740B	I_Z	max.	25	mA	I_{ZSM}	max.	1,20	A
IN5741B	I_Z	max.	20	mA	I_{ZSM}	max.	1,13	A
IN5742B	I_Z	max.	20	mA	I_{ZSM}	max.	1,05	A
IN5743B	I_Z	max.	15	mA	I_{ZSM}	max.	0,98	A
IN5744B	I_Z	max.	15	mA	I_{ZSM}	max.	0,90	A
IN5745B	I_Z	max.	15	mA	I_{ZSM}	max.	0,83	A
IN5746B	I_Z	max.	10	mA	I_{ZSM}	max.	0,75	A
IN5747B	I_Z	max.	10	mA	I_{ZSM}	max.	0,68	A
IN5748B	I_Z	max.	10	mA	I_{ZSM}	max.	0,64	A
IN5749B	I_Z	max.	10	mA	I_{ZSM}	max.	0,60	A
IN5750B	I_Z	max.	9	mA	I_{ZSM}	max.	0,57	A
IN5751B	I_Z	max.	9	mA	I_{ZSM}	max.	0,53	A
IN5752B	I_Z	max.	8	mA	I_{ZSM}	max.	0,49	A
IN5753B	I_Z	max.	7	mA	I_{ZSM}	max.	0,45	A
IN5754B	I_Z	max.	6	mA	I_{ZSM}	max.	0,42	A
IN5755B	I_Z	max.	6	mA	I_{ZSM}	max.	0,38	A
IN5756B	I_Z	max.	5	mA	I_{ZSM}	max.	0,34	A
IN5757B	I_Z	max.	5	mA	I_{ZSM}	max.	0,30	A

Power dissipation

Total power dissipation P_{tot} max. 400 mW 1)
max. 500 mW 2)

Non-repetitive peak reverse power dissipation

$t = 100\text{ }\mu\text{s}$; $T_j = 150\text{ }^{\circ}\text{C}$; square wave

P_{ZSM} max. 30 W

Temperatures

Storage temperature T_{stg} -65 to +200 $^{\circ}\text{C}$

Junction temperature T_j max. 200 $^{\circ}\text{C}$

1) In still air at maximum lead length up to $T_{amb} = 50\text{ }^{\circ}\text{C}$

2) If leads are kept at $T_{amb} = 25\text{ }^{\circ}\text{C}$ at 8 mm from body.

THERMAL RESISTANCE

From junction to ambient in still air
at maximum lead length

$$R_{th\ j-a} = 0,38 \text{ } ^\circ\text{C/mW } 1)$$

CHARACTERISTICS E24 ($\pm 5\%$) logarithmic range $T_j = 25 \text{ } ^\circ\text{C}$

	Working voltage V_Z (V) at $I_Z = 10 \text{ mA}$			Temperature coefficient S_Z (mV/ $^\circ\text{C}$) at $I_Z = 10 \text{ mA}$	Differential impedance Z_{diff} (Ω) at $I_Z = 10 \text{ mA}$ $f = 1 \text{ kHz}$
	min.	nom.	max.	typ.	max.
1N5729B	4,8	5,1	5,4	-0,2	50
1N5730B	5,2	5,6	6,0	+1,2	25
1N5731B	5,8	6,2	6,6	+2,3	10
1N5732B	6,4	6,8	7,2	+3,0	10
1N5733B	7,0	7,5	7,9	+4,0	10
1N5734B	7,7	8,2	8,7	+5,0	15
1N5735B	8,5	9,1	9,6	+6,0	15
1N5736B	9,4	10,0	10,6	+7,0	20
	at $I_Z = 5 \text{ mA}$			at $I_Z = 5 \text{ mA}$	at $I_Z = 5 \text{ mA}$
1N5737B	10,4	11,0	11,6	+8,0	20
1N5738B	11,4	12,0	12,7	+9,0	25
1N5739B	12,4	13,0	14,1	+10,5	30
1N5740B	13,8	15,0	15,6	+12,5	30
1N5741B	15,3	16,0	17,1	+13,0	40
1N5742B	16,8	18,0	19,1	+15,0	45
1N5743B	18,8	20,0	21,2	+17,0	55
1N5744B	20,8	22,0	23,3	+19,0	55
1N5745B	22,8	24,0	25,6	+21,0	70
	at $I_Z = 2 \text{ mA}$			at $I_Z = 2 \text{ mA}$	at $I_Z = 2 \text{ mA}$
1N5746B	25,1	27,0	28,9	+23,5	80
1N5747B	28,0	30,0	32,0	+26	80
1N5748B	31,0	33,0	35,0	+29	90
1N5749B	34,0	36,0	38,0	+31	90
1N5750B	37,0	39,0	41,0	+34	130
1N5751B	40,0	43,0	46,0	+37	150
1N5752B	44,0	47,0	50,0	+40	170
1N5753B	48,0	51,0	54,0	+44	180
1N5754B	52,0	56,0	60,0	+47	200
1N5755B	58,0	62,0	66,0	+51	215
1N5756B	64,0	68,0	72,0	+56	240
1N5757B	70,0	75,0	79,0	+60	255

1) Measured in still air at maximum lead length.

1N5729B to 1N5757B

CHARACTERISTICS

$T_j = 25\text{ }^\circ\text{C}$ unless otherwise specified

Forward voltage

$I_F = 10\text{ mA}; T_{amb} = 25\text{ }^\circ\text{C}$

$V_F < 0,9\text{ V}$

Reverse current

1N5729B	$V_R = 2\text{ V}$	$I_R < 2000\text{ nA}$
1N5730B	$V_R = 2\text{ V}$	$I_R < 1000\text{ nA}$
1N5731B	$V_R = 4\text{ V}$	$I_R < 3000\text{ nA}$
1N5732B	$V_R = 4\text{ V}$	$I_R < 2000\text{ nA}$
1N5733B	$V_R = 5\text{ V}$	$I_R < 1000\text{ nA}$
1N5734B	$V_R = 5\text{ V}$	$I_R < 700\text{ nA}$
1N5735B	$V_R = 6\text{ V}$	$I_R < 500\text{ nA}$
1N5736B	$V_R = 7\text{ V}$	$I_R < 200\text{ nA}$
1N5737B	$V_R = 8\text{ V}$	$I_R < 100\text{ nA}$
1N5738B to 1N5757B	$V_R = 0,7 \times V_{Znom}$	$I_R < 50\text{ nA}$



Voltage reference diodes



VOLTAGE REFERENCE DIODES

The BZV10 to 14 are temperature compensated voltage reference diodes in a DO-35 envelope. They are primarily intended for use as voltage reference sources in measuring instruments such as digital voltmeters.

QUICK REFERENCE DATA					
		min.	nom.	max.	
Reference voltage at $I_Z = 2,0 \text{ mA}$	V_{ref}	6,175	6,5	6,825	V
Reference voltage excursion at $I_Z = 2,0 \text{ mA}$					
Ambient temperature test points: 0; +25 °C and +70 °C (see notes 1 and 2 on page 3 and the graph on page 4)	<u>BZV10</u>	$ \Delta V_{\text{ref}} $	<	46,0	mV
	<u>BZV11</u>	$ \Delta V_{\text{ref}} $	<	23,0	mV
	<u>BZV12</u>	$ \Delta V_{\text{ref}} $	<	9,0	mV
	<u>BZV13</u>	$ \Delta V_{\text{ref}} $	<	4,6	mV
	<u>BZV14</u>	$ \Delta V_{\text{ref}} $	<	2,3	mV
Operating ambient temperature	T_{amb}	0 to +70			°C

MECHANICAL DATA

Dimensions in mm

DO-35

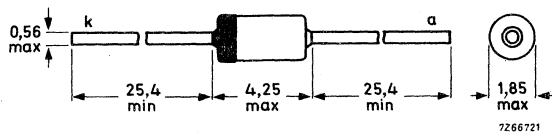

Cathode indicated by coloured band

RATINGS Limiting values in accordance with the Absolute Maximum System (IEC134)

Currents

Working current (d. c.)	I_Z	max.	50	mA
Working current (peak value)	I_{ZM}	max.	50	mA

Power dissipation

Total power dissipation up to $T_{amb} = 50\text{ }^\circ\text{C}$	P_{tot}	max.	400	mW
--	-----------	------	-----	----

Temperatures

Storage temperature	T_{stg}	-65 to +200	$^\circ\text{C}$
Operating ambient temperature	T_{amb}	0 to +70	$^\circ\text{C}$

THERMAL RESISTANCE

From junction to ambient in free air	$R_{th\ j-a}$	=	0,375	$^\circ\text{C}/\text{mW}$
--------------------------------------	---------------	---	-------	----------------------------

CHARACTERISTICS

$T_{amb} = 25\text{ }^\circ\text{C}$ unless otherwise specified

		min.	nom.	max.	
Reference voltage at $I_Z = 2,0\text{ mA}$	V_{ref}	6,175	6,5	6,825	V

Reference voltage excursion at $I_Z = 2,0\text{ mA}$

Ambient temperature test points: 0; +25 $^\circ\text{C}$ and +70 $^\circ\text{C}$ (see notes 1 and 2 on the next page and the graph on page 4)	<u>BZV10</u>	$ \Delta V_{ref} $	<	46,0	mV
	<u>BZV11</u>	$ \Delta V_{ref} $	<	23,0	mV
	<u>BZV12</u>	$ \Delta V_{ref} $	<	9,0	mV
	<u>BZV13</u>	$ \Delta V_{ref} $	<	4,6	mV
	<u>BZV14</u>	$ \Delta V_{ref} $	<	2,3	mV

Temperature coefficient at $I_Z = 2,0\text{ mA}$

(see notes 1 and 2 on the next page and the graph on page 4)	<u>BZV10</u>	S_Z	$\pm 0,01$	$\%/^\circ\text{C}$
	<u>BZV11</u>	S_Z	$\pm 0,005$	$\%/^\circ\text{C}$
	<u>BZV12</u>	S_Z	$\pm 0,002$	$\%/^\circ\text{C}$
	<u>BZV13</u>	S_Z	$\pm 0,001$	$\%/^\circ\text{C}$
	<u>BZV14</u>	S_Z	$\pm 0,0005$	$\%/^\circ\text{C}$

Differential resistance at $I_Z = 2,0\text{ mA}$

r_{diff}	typ.	30	Ω
	<	50	Ω

Note 1 I_Z tolerance and stability of I_Z .

The quoted values of ΔV_{ref} are based on a constant current I_Z . Two factors can cause V_{ref} to change, namely the differential resistance r_{diff} and the temperature coefficient S_Z .

- a As the max. r_{diff} of the device can be 50Ω , a change of $0,01 \text{ mA}$ in the current through the reference diode will result in a ΔV_{ref} of $0,01 \text{ mA} \times 50 \Omega = 0,5 \text{ mV}$. This level of ΔV_{ref} is not significant on a BZV10 ($\Delta V_{\text{ref}} < 46 \text{ mV}$), it is however very significant on a BZV14 ($\Delta V_{\text{ref}} < 2,3 \text{ mV}$).
- b The temperature coefficient of the reference voltage S_Z is a function of I_Z . Reference diodes are classified at the specified test current and the S_Z of the reference diode will be different at different levels of I_Z . The absolute value of I_Z is important, however, the stability of I_Z , once the level has been set, is far more significant. This applies particularly to the BZV13 and BZV14. The effect of I_Z stability on S_Z is shown in the graph on page 4.

Note 2 Voltage excursion (ΔV_{ref} and temperature coefficient).

All reference diodes are characterized by the 'box method'. This guarantees a maximum voltage excursion (ΔV_{ref}) over the specified temperature range, at the specified test current (I_Z), verified by tests at indicated temperature points within the range. V_Z is measured and recorded at each temperature specified. The ΔV_{ref} between the highest and lowest values must not exceed the maximum ΔV_{ref} given. The temperature coefficient, therefore is given only as a reference; but may be derived from:

$$S_Z = \frac{(V_{\text{ref } 1} - V_{\text{ref } 2}) \times 100}{(T_{\text{amb } 2} - T_{\text{amb } 1}) \times V_{\text{ref nom}}} \% / ^\circ\text{C}$$

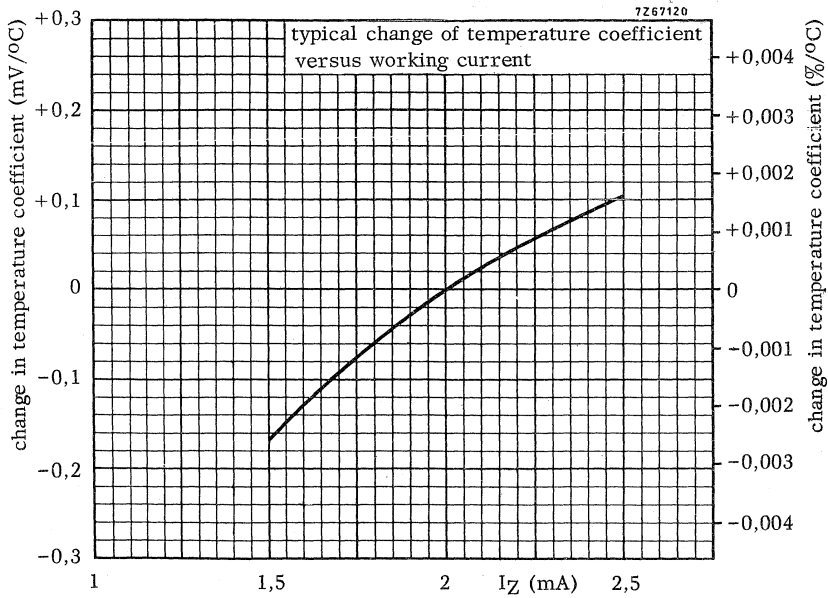
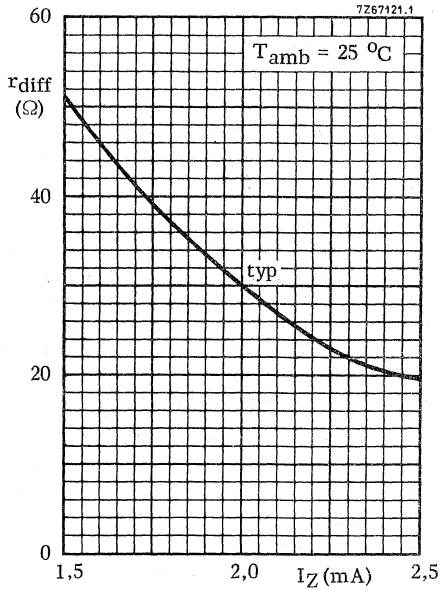

VOLTAGE REFERENCE DIODE

The BZV38 is a temperature-compensated voltage reference diode in a DO-35 envelope, primarily intended for use as the stabilizing element for the TCA750 integrated multi-stabilizer in radio and television receivers with variable capacitance diode tuning systems.

QUICK REFERENCE DATA			
	min.	nom.	max.
Reference voltage at $I_Z = 7,5 \text{ mA}$	V_{Ref} 6,08	6,40	6,72 V
Reference voltage excursion at $I_Z = 7,5 \text{ mA}$ (see also note 1 on page 2)	$ \Delta V_{\text{Ref}} $	< 20	mV
Operating ambient temperature	T_{amb}	+10 to +60	$^{\circ}\text{C}$

MECHANICAL DATA

Dimensions in mm

DO-35

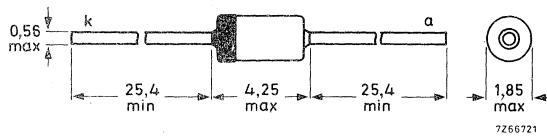

The coloured band indicates the cathode

RATINGS Limiting values in accordance with the Absolute Maximum System (IEC134)Currents

Working current (d. c.)	I_Z	max.	50	mA
Working current (peak value)	I_{ZM}	max.	50	mA

Temperatures

Storage temperature	T_{stg}	-65 to +200	°C
Operating ambient temperature	T_{amb}	+10 to +60	°C

THERMAL RESISTANCE

From junction to ambient in free air	$R_{th\ j-a}$	=	0,4	°C/mW
--------------------------------------	---------------	---	-----	-------

CHARACTERISTICS $T_{amb} = 25\text{ °C}$ unless otherwise specified

		<u>min.</u>	<u>nom.</u>	<u>max.</u>	
<u>Reference voltage</u> at $I_Z = 7,5\text{ mA}$	V_{ref}	6,08	6,40	6,72	V
<u>Reference voltage excursion</u> at $I_Z = 7,5\text{ mA}$ in the temperature range +10 to +60 °C	$ \Delta V_{ref} $	<	20		mV 1)
<u>Differential resistance</u> at $I_Z = 7,5\text{ mA}$	r_{diff}	<	20		Ω 2)
<u>Stabilizing time</u>	t_{stab}	<	1		s 3)
<u>Noise voltage</u> at $I_Z = 7,5\text{ mA}$ $f = 0,1\text{ Hz}$ to 15 kHz	$V_n (p-p)$	<	20		μV

- 1) The maximum absolute change of the diode voltage over the stated temperature range, at a constant working current setting of $I_Z = 7,5\text{ mA} \pm 2\%$.
- 2) Measured by superimposing a 1 kHz current on the specified working current. The r. m. s. value of the 1 kHz current is 10% of the specified working current.
- 3) Stabilizing time is the time it takes the voltage to approach within 3 mV of the specified reference voltage.

VOLTAGE REFERENCE DIODES

Voltage reference diodes in a DO-35 envelope. They have a very low temperature coefficient and are primarily intended for use as reference sources.

QUICK REFERENCE DATA				
		min.	nom.	max.
Reference voltage at $I_Z = 7,5 \text{ mA}$	V_{ref}	6,2	6,5	6,8 V
Temperature coefficient at $I_Z = 7,5 \text{ mA}$ ¹⁾				
	<u>BZX90:</u>	$ S_Z <$	0,01	%/°C
	<u>BZX91:</u>	$ S_Z <$	0,005	%/°C
	<u>BZX92:</u>	$ S_Z <$	0,002	%/°C
	<u>BZX93:</u>	$ S_Z <$	0,001	%/°C
Operating ambient temperature	T_{amb}	-55 to +100		°C

MECHANICAL DATA

Dimensions in mm

DO-35

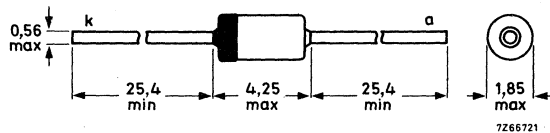

Cathode indicated by coloured band

¹⁾ For accuracy of I_Z see graphs on page 5.

RATINGS Limiting values in accordance with the Absolute Maximum System (IEC 134)

Currents

Working current (d. c.)	I_Z	max.	50	mA
Working current (peak value)	I_{ZM}	max.	50	mA

Power dissipation

Total power dissipation up to $T_{amb} = 50\text{ }^\circ\text{C}$	P_{tot}	max.	400	mW
--	-----------	------	-----	----

Temperatures

Storage temperature	T_{stg}	-65 to +200	$^\circ\text{C}$
Operating ambient temperature	T_{amb}	-55 to +100	$^\circ\text{C}$

THERMAL RESISTANCE

From junction to ambient in free air	$R_{th\ j-a}$	=	0,375	$^\circ\text{C}/\text{mW}$
--------------------------------------	---------------	---	-------	----------------------------

CHARACTERISTICS

$T_{amb} = 25\text{ }^\circ\text{C}$ unless otherwise specified

			<u>min.</u>	<u>nom.</u>	<u>max.</u>	
<u>Reference voltage at $I_Z = 7,5\text{ mA}$</u>	V_{ref}		6,2	6,5	6,8	V

Reference voltage excursion at $I_Z = 7,5\text{ mA}$ 1)

$T_{amb} = -55\text{ to }+25\text{ }^\circ\text{C}$	<u>BZX90:</u>	$ \Delta V_{ref} $	<	52	mV
	<u>BZX91:</u>	$ \Delta V_{ref} $	<	26	mV
	<u>BZX92:</u>	$ \Delta V_{ref} $	<	10,4	mV
	<u>BZX93:</u>	$ \Delta V_{ref} $	<	5,2	mV
$T_{amb} = +25\text{ to }+100\text{ }^\circ\text{C}$	<u>BZX90:</u>	$ \Delta V_{ref} $	<	48	mV
	<u>BZX91:</u>	$ \Delta V_{ref} $	<	24	mV
	<u>BZX92:</u>	$ \Delta V_{ref} $	<	9,6	mV
	<u>BZX93:</u>	$ \Delta V_{ref} $	<	4,8	mV

Temperature coefficient at $I_Z = 7,5\text{ mA}$ 1)

$T_{amb} = -55\text{ to }+100\text{ }^\circ\text{C}$	<u>BZX90:</u>	$ S_Z $	<	0,01	$\%/^\circ\text{C}$
	<u>BZX91:</u>	$ S_Z $	<	0,005	$\%/^\circ\text{C}$
	<u>BZX92:</u>	$ S_Z $	<	0,002	$\%/^\circ\text{C}$
	<u>BZX93:</u>	$ S_Z $	<	0,001	$\%/^\circ\text{C}$

Differential resistance at $I_Z = 7,5\text{ mA}$

r_{diff}	<	15	Ω
------------	---	----	----------

1) For accuracy of I_Z see graphs on page 5.

NOTE

The temperature coefficient (S_Z) of the reference voltage (V_{ref}) is obtained from the following equation:

$$S_Z = \frac{V_{ref1} - V_{ref2}}{(T_{amb2} - T_{amb1}) \times V_{refnom}} \times 100\text{ } \%/^\circ\text{C}$$

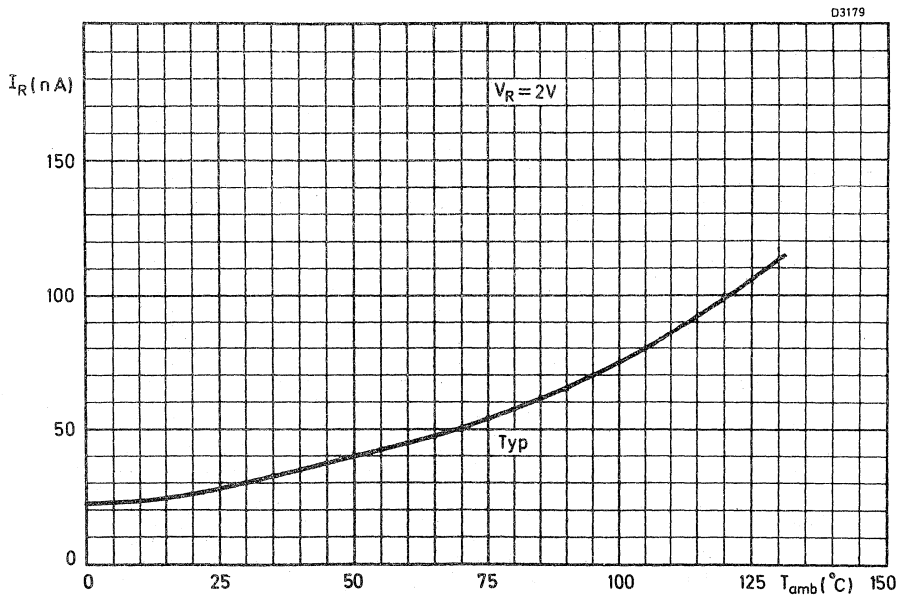
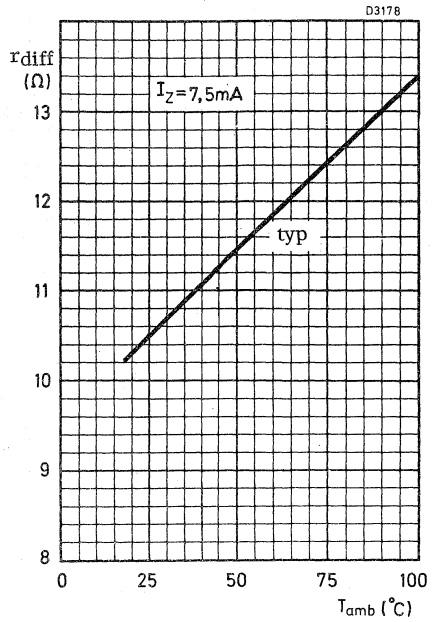
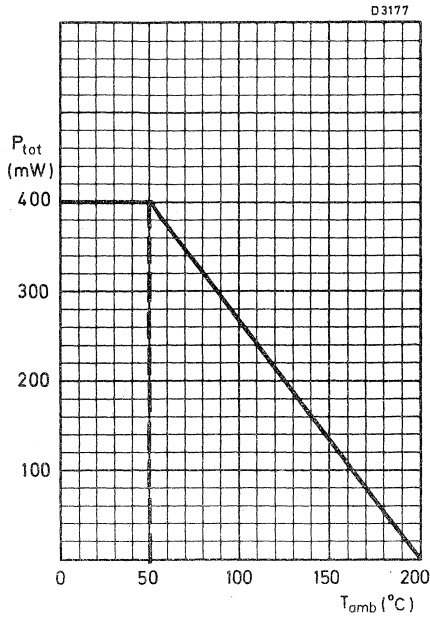

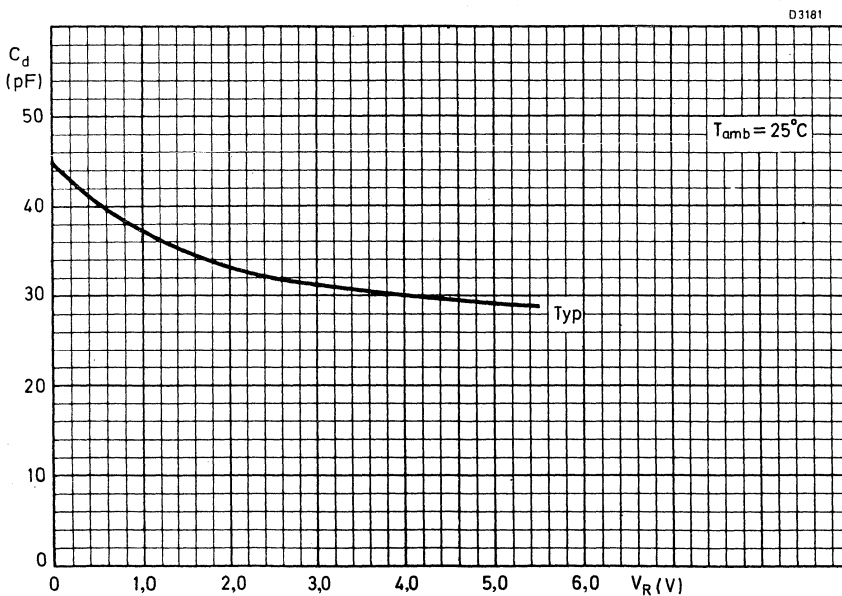
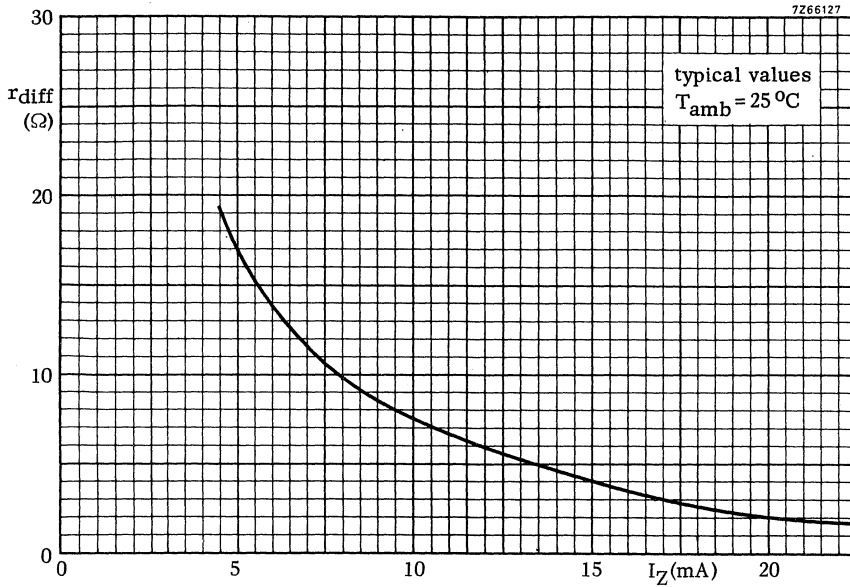

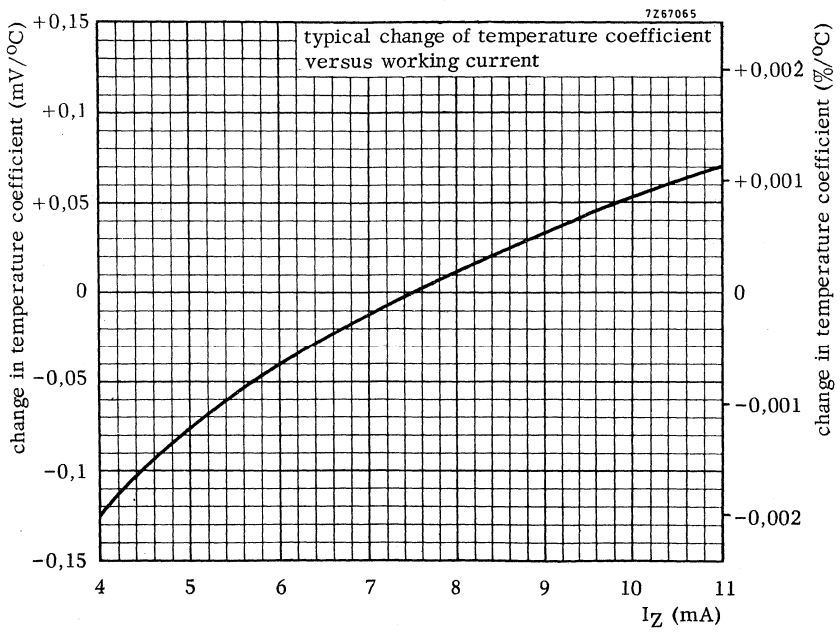
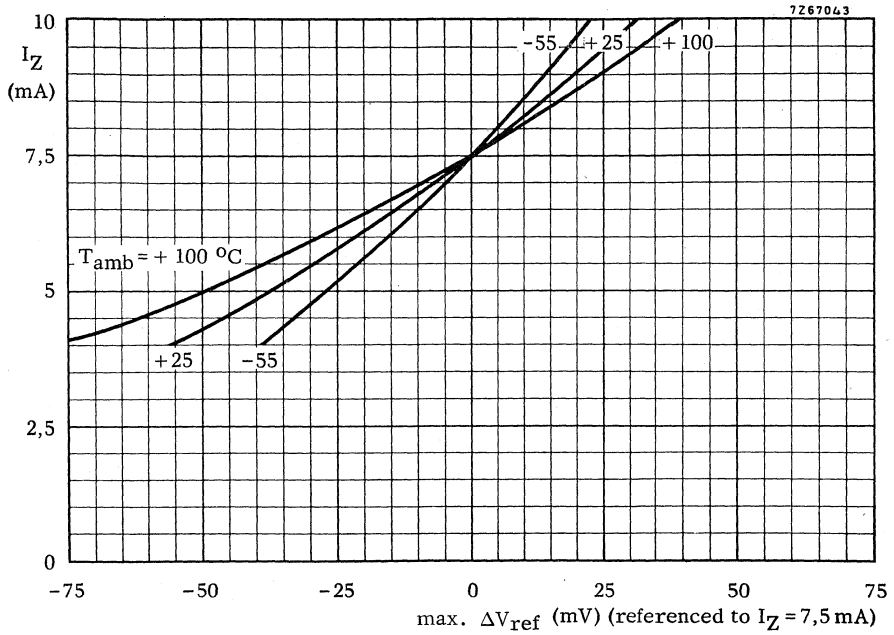

VOLTAGE REFERENCE DIODE

Silicon diode in a DO-7 envelope intended for use as a voltage reference diode in general industrial applications.

The BZY78 has an extremely high voltage stability ($\pm 1\%$ at a working current of 11,5 mA).

QUICK REFERENCE DATA			
Working voltage at $I_Z = 11,5 \text{ mA}$	V_Z	nom. 5,3 V 5,1 to 5,6 V	
Voltage stability at T_{amb} from -50 to $100 \text{ }^\circ\text{C}$ $I_Z = 11,5 \text{ mA} (\pm 10\%)$	$\frac{\Delta V_Z}{V_Z}$	-1 to +1	%
Repetitive peak working current	I_{ZRM}	max. 25	mA
Total power dissipation up to $T_{amb} = 50 \text{ }^\circ\text{C}$	P_{tot}	max. 400	mW
Operating junction temperature	T_j	max. 200	$^\circ\text{C}$
Thermal resistance	$R_{th \text{ j-a}}$	= 0,37	$^\circ\text{C}/\text{mW}$

MECHANICAL DATA

Dimensions in mm

DO-7

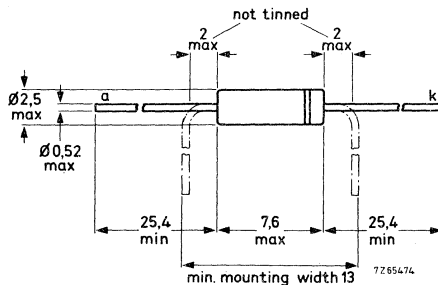

Cathode indicated by coloured band

RATINGS Limiting values in accordance with the Absolute Maximum System (IEC134)

Currents

Average forward current (averaged over any 20 ms period)	$I_{F(AV)}$	max.	50	mA
Repetitive peak forward current	I_{FRM}	max.	50	mA
Working current (d.c. or averaged over any 20 ms period)	I_Z	max.	25	mA
Repetitive peak working current	I_{ZRM}	max.	25	mA

Power dissipation

Total power dissipation up to $T_{amb} = 50\text{ }^\circ\text{C}$	P_{tot}	max.	400	mW
--	-----------	------	-----	----

Temperatures

Storage temperature	T_{stg}	-65 to +175	$^\circ\text{C}$
Operating junction temperature	T_j	max.	200 $^\circ\text{C}$

THERMAL RESISTANCE

From junction to ambient	$R_{th\ j-a}$	=	0,37	$^\circ\text{C}/\text{mW}$
--------------------------	---------------	---	------	----------------------------

CHARACTERISTICS

$T_j - 25\text{ }^\circ\text{C}$ unless otherwise specified

<u>Working voltage</u> at $I_Z = 11,5\text{ mA}$	V_Z	nom.	5,3	V
			5,1 to 5,6	V
<u>Forward voltage</u> at $I_F = 1\text{ mA}$	V_F		0,65 to 0,75	V
<u>Reverse current</u> at $V_R = 2\text{ V}$	I_R	<	1,0	μA

Temperature coefficient

$I_Z = 11,5\text{ mA}$ ($\pm 10\%$); $T_j = -40$ to $+25\text{ }^\circ\text{C}$	S_Z	typ.	+0,32	$\text{mV}/^\circ\text{C}$
$T_j = +25$ to $+100\text{ }^\circ\text{C}$	S_Z	typ.	-0,21	$\text{mV}/^\circ\text{C}$

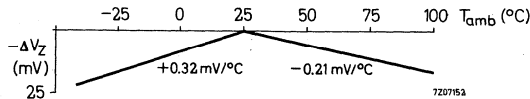

<u>Differential resistance</u> at $I_Z = 11,5\text{ mA}$	r_{diff}	typ.	18	Ω
			15 to 20	Ω

Voltage stability at $T_{amb} = -50$ to $+100\text{ }^\circ\text{C}$

$I_Z = 11,5\text{ mA}$ ($\pm 10\%$)	$\frac{\Delta V_Z}{V_Z}$	-1 to +1	%
---------------------------------------	--------------------------	----------	---

MOUNTING INSTRUCTIONS

1. When using a soldering iron, the diode may be soldered directly into a circuit, but heat conducted to the junction should be kept to a minimum by use of a thermal shunt.
2. Diodes may be dip soldered at a solder temperature of 245 °C for a maximum soldering time of 5 seconds. The case temperature during dip soldering may exceed the maximum storage temperature for a period not greater than 2 minutes, provided that it at no time exceeds 115 °C. These recommendations apply to a diode with the anode end mounted flush on the board with punched-through holes or spaced at least 1.5 mm above a board with plated-through holes. For mounting the cathode end onto the board the diode must be spaced at least 5 mm from the underside of the printed circuit board in the case of punched-through holes or 5 mm from the top of the board for plated-through holes.
3. Care should be taken not to bend the leads nearer than 1.5 mm from the seals.

APPLICATION INFORMATION

Typical reference-voltage circuit

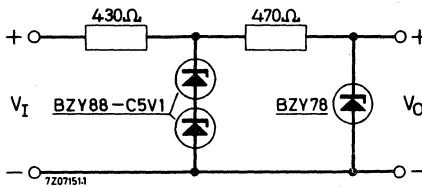

Temperature range	T_{amb}	0 to +50 °C	
Input voltage	V_I	24 V	± 10%
Output voltage	V_O	5.1 to 5.6 V	±0.3%

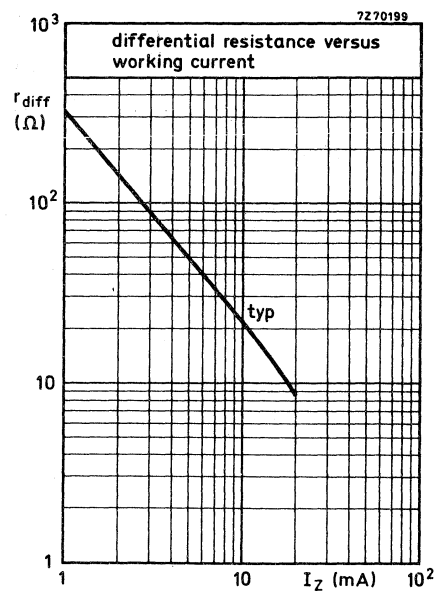
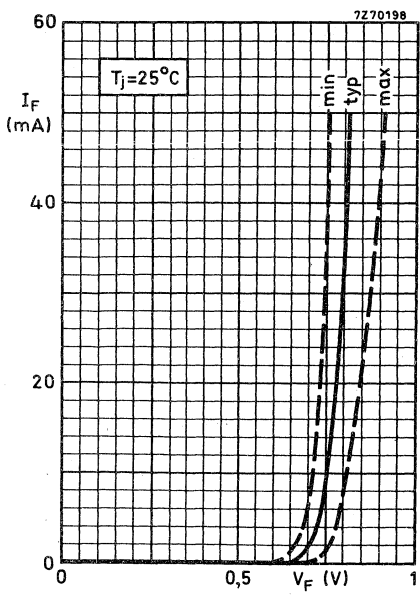
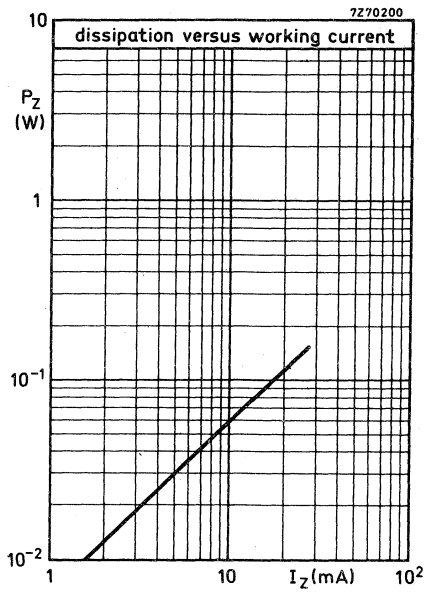

VOLTAGE REFERENCE DIODES

Voltage reference diodes in a DO-35 envelope. They have a very low temperature coefficient and are primarily intended for use as voltage reference sources in measuring instruments such as digital voltmeters.

QUICK REFERENCE DATA					
		min.	nom.	max.	
Reference voltage at $I_Z = 7,5 \text{ mA}$	V_{ref}	5,89	6,20	6,51	V
Reference voltage excursion at $I_Z = 7,5 \text{ mA}$ ¹⁾					
(see notes 1 and 2 on page 3 and the graphs on pages 4 and 5)	1N821	$ \Delta V_{\text{ref}} <$	96	mV	
	1N823	$ \Delta V_{\text{ref}} <$	48	mV	
	1N825	$ \Delta V_{\text{ref}} <$	19	mV	
	1N827	$ \Delta V_{\text{ref}} <$	9	mV	
	1N829	$ \Delta V_{\text{ref}} <$	5	mV	
Operating ambient temperature	T_{amb}	-55 to +100		°C	

MECHANICAL DATA

Dimensions in mm

DO-35

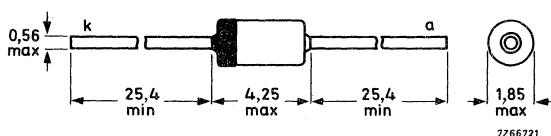

Cathode indicated by coloured band

1) For accuracy of I_Z see graphs on pages 4 and 5.

RATINGS Limiting values in accordance with the Absolute Maximum System (IEC134)

Currents

Working current (d. c.)	I_Z	max.	50	mA
Working current (peak value)	I_{ZM}	max.	50	mA

Power dissipation

Total power dissipation up to $T_{amb} = 50\text{ }^\circ\text{C}$	P_{tot}	max.	400	mW
--	-----------	------	-----	----

Temperatures

Storage temperature	T_{stg}	-65 to +200	$^\circ\text{C}$
Operating ambient temperature	T_{amb}	-55 to +100	$^\circ\text{C}$

THERMAL RESISTANCE

From junction to ambient in free air	$R_{th\ j-a}$	=	0,375	$^\circ\text{C}/\text{mW}$
--------------------------------------	---------------	---	-------	----------------------------

CHARACTERISTICS

$T_j = 25\text{ }^\circ\text{C}$ unless otherwise specified

	<u>min.</u>	<u>nom.</u>	<u>max.</u>
<u>Reference voltage</u> at $I_Z = 7,5\text{ mA}$	V_{ref} 5,89	6,20	6,51

Reference voltage excursion at $I_Z = 7,5\text{ mA}$ 1)

ambient temperature test points: -55; +25; +75; +100 $^\circ\text{C}$ (see notes 1 and 2 on the next page and the graphs on pages 4 and 5)	1N821	$ \Delta V_{ref} <$	96	mV
	1N823	$ \Delta V_{ref} <$	48	mV
	1N825	$ \Delta V_{ref} <$	19	mV
	1N827	$ \Delta V_{ref} <$	9	mV
	1N829	$ \Delta V_{ref} <$	5	mV

Effective temperature coefficient at $I_Z = 7,5\text{ mA}$ 1)

(see notes 1 and 2 on the next page and the graphs on pages 4 and 5)	1N821	S_Z	$\pm 0,01$	$\%/^\circ\text{C}$
	1N823	S_Z	$\pm 0,005$	$\%/^\circ\text{C}$
	1N825	S_Z	$\pm 0,002$	$\%/^\circ\text{C}$
	1N827	S_Z	$\pm 0,001$	$\%/^\circ\text{C}$
	1N829	S_Z	$\pm 0,0005$	$\%/^\circ\text{C}$

<u>Differential resistance</u> at $I_Z = 7,5\text{ mA}$	r_{diff}	$<$	15	Ω
---	------------	-----	----	----------

1) For accuracy of I_Z see graphs on pages 4 and 5.

Note 1 I_Z tolerance and stability of I_Z .

The quoted values of ΔV_{ref} are based on a constant current I_Z . Two factors can cause V_{ref} to change, namely the differential resistance r_{diff} and the temperature coefficient S_Z .

- a As the max. r_{diff} of the device can be 15Ω , a change of $0,01 \text{ mA}$ in the current through the reference diode will result in a ΔV_{ref} of $0,01 \text{ mA} \times 15 \Omega = 0,15 \text{ mV}$. This level of ΔV_{ref} is not significant on a 1N821 ($\Delta V_{ref} < 96 \text{ mV}$), it is however very significant on a 1N829 ($\Delta V_{ref} < 5 \text{ mV}$).
- b The temperature coefficient of the reference voltage S_Z is a function of I_Z . Reference diodes are classified at the specified test current and the S_Z of the reference diode will be different at different levels of I_Z . The absolute value of I_Z is important, however, the stability of I_Z , once the level has been set, is far more significant. This applies particularly to the 1N829. The effect of I_Z stability on S_Z is shown in the graph on page 5.

Note 2 Voltage excursion (ΔV_{ref} and temperature coefficient).

All reference diodes are characterized by the 'box method'. This guarantees a maximum voltage excursion (ΔV_{ref}) over the specified temperature range, at the specified test current (I_Z), verified by tests at indicated temperature points within the range. V_Z is measured and recorded at each temperature specified. The ΔV_{ref} between the highest and lowest values must not exceed the maximum ΔV_{ref} given. The temperature coefficient, therefore is given only as a reference; but may be derived from:

$$S_Z = \frac{(V_{ref 1} - V_{ref 2}) \times 100}{(T_{amb 2} - T_{amb 1}) \times V_{ref nom}} \% / ^\circ\text{C}$$



1N821 ; 1N823
 1N825 ; 1N827
 1N829

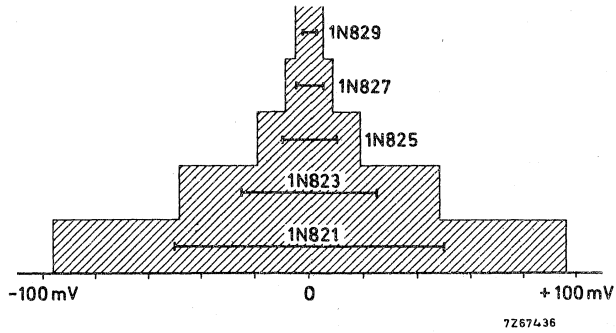

Maximum reference voltage variation (line section) caused by temperature variations within the range from -55°C to $+100^{\circ}\text{C}$ at a constant working current of $7,5\text{ mA}$. The voltage variations may shift horizontally within the shaded area. The zero point may vary from 5890 mV to 6510 mV and differs from diode to diode.

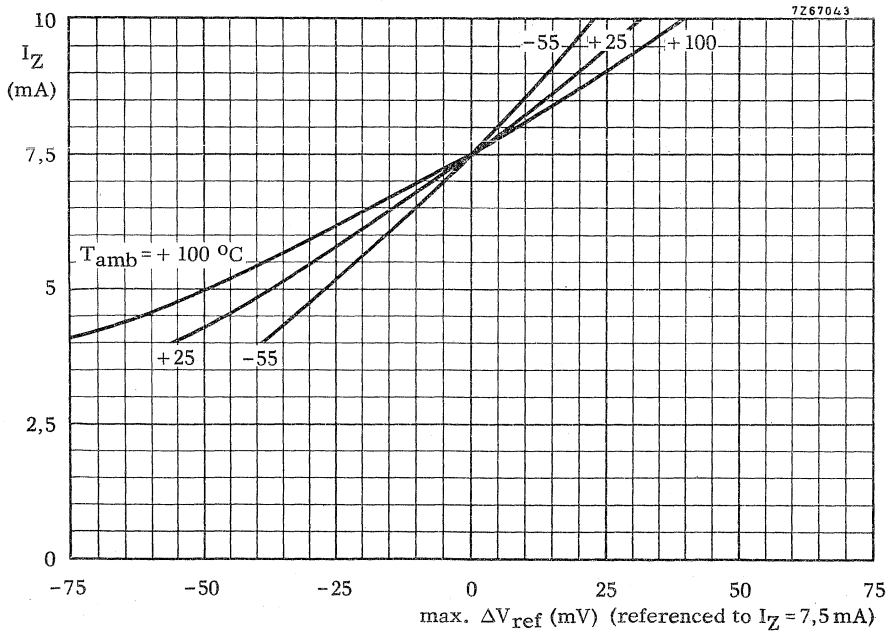

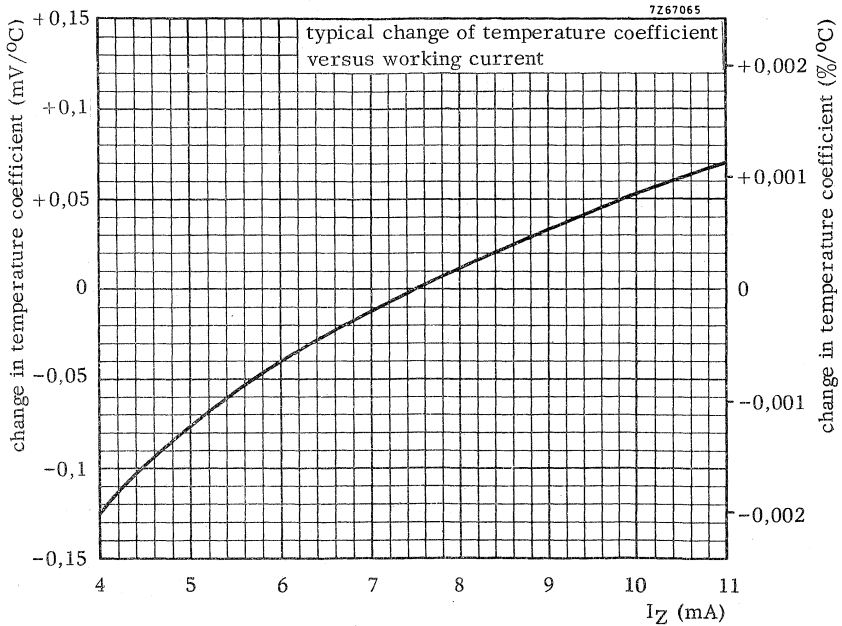
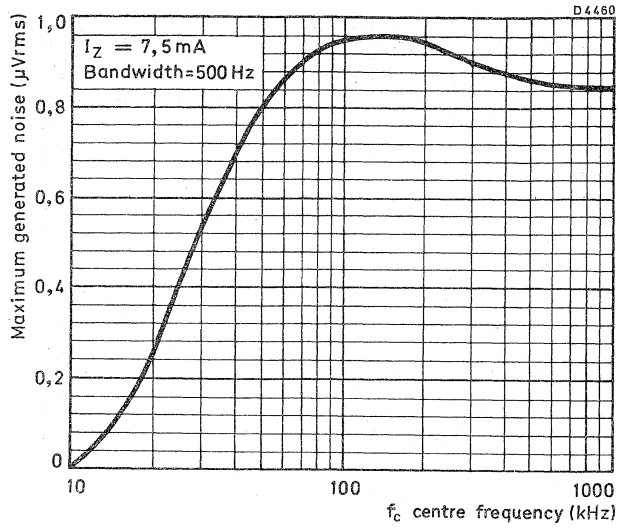

1N821; 1N823
1N825; 1N827
1N829

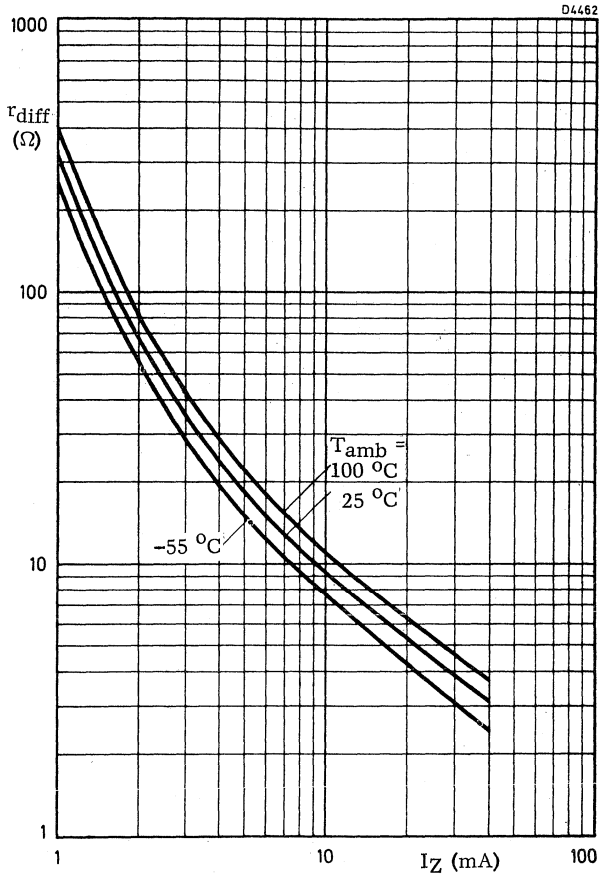

Tuner diodes

Variable capacitance diodes

Band switching diodes



TUNER DIODES

	type	envelope	V_R (V)	C_d at V_R (pF)	V_R (V)	C_d ratio at V_R (. V / . V)	
Variable capacitance diodes							
a. f. c. in radio and television	BB117	SOD-23	20	2, 2-4, 0	15	> 2, 0 4/15	
	BA102	DO-7	20	20 - 45	4	> 1, 4 4/10	
radio f. m. band II	→ BB204B	TO-92	30	37 - 42	3	= 2, 65 3/30	
	→ BB204G	TO-92	30	34 - 39	3	= 2, 65 3/30	
	BB110B	SOD-23	30	29 - 33	3	= 2, 65 3/30	
	BB110G	SOD-23	30	27 - 31	3	= 2, 65 3/30	
television v. h. f.							
Band I to 88 MHz Band III to 230 MHz	BB106	SOD-23	28	4, 0-5, 6	25	> 4, 5 3/25	
Band I to 88 MHz } Band III to 230 MHz }	→ {	BB105G	SOD-23	28	1, 8-2, 8	25	> 4, 0 3/25
		BB205G	SOD-23	28	1, 8-2, 6	25	> 4, 3 3/25
television u. h. f.							
Band IV and V to 790 MHz	BB105A	SOD-23	28	2, 3-2, 8	25	> 4, 0 3/25	
	→ BB205A	SOD-23	28	2, 0-2, 5	25	> 4, 3 3/25	
Band IV and V to 860 MHz	BB105B	SOD-23	28	2, 0-2, 3	25	> 4, 5 3/25	
	→ BB205B	SOD-23	28	1, 9-2, 2	25	> 5, 0 3/25	
Band switching diodes						r_D at I_F (Ω) (mA)	
switching	BA182	SOD-23	35	< 1, 0	20	< 0, 7 5	
switching	BA243	DO-35	20	< 2, 0	15	< 1, 0 10	
switching	BA244	DO-35	20	< 2, 0	15	< 0, 5 10	
attenuator (p-i-n diode)	BA379	-	30	= 0, 3	0	< 6, 5 10	

→ Note:

BB105A; BB105B; BB105G; BB106; BB205A; BB205B; BB205G will be supplied in matched sets.

Over the voltage range 0, 5 V to 28 V the diodes in a unit are capacitance matched to within

3%: BB105A; BB105B; BB106; BB205A; BB205B; BB205G

6%: BB105G

SILICON VARIABLE CAPACITANCE DIODE

Diode in all-glass DO-7 envelope intended for automatic frequency control in radio and television receivers.

QUICK REFERENCE DATA			
Continuous reverse voltage	V_R	max.	20 V
Reverse current at $V_R = 20$ V; $T_j = 80$ °C	I_R	<	5 μ A
Junction temperature	T_j	max.	90 °C
Diode capacitance at $f = 0,5$ MHz; $V_R = 4$ V (for selections see page 2)	C_d		20 to 45 pF
Capacitance ratio at $f < 300$ MHz	$\frac{C_d(V_R = 4\text{ V})}{C_d(V_R = 10\text{ V})}$	>	1,4
Series resistance at $V_R = 4$ V	r_D	<	3 Ω

MECHANICAL DATA

Dimensions in mm

DO-7

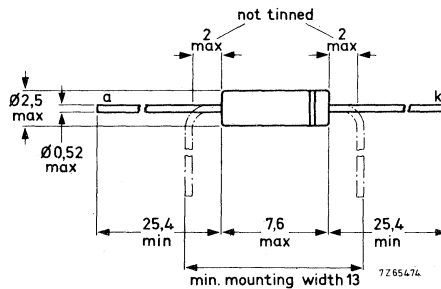

Cathode indicated by white band

RATINGS Limiting values in accordance with the Absolute Maximum System (IEC134)

Voltage

Continuous reverse voltage V_R max. 20 V

Current

Forward current (d.c.) I_F max. 50 mA

Temperatures

Storage temperature T_{stg} -55 to +90 °C

Junction temperature T_j max. 90 °C

THERMAL RESISTANCE

From junction to ambient in free air $R_{th j-a}$ = 0,5 °C/mW

CHARACTERISTICS

$T_j = 25$ °C unless otherwise specified

Reverse current at $T_j = 80$ °C

$V_R = 20$ V I_R < 5 μ A

Diode capacitance at $f = 0,5$ MHz

$V_R = 4$ V

Selections:	{	BA102	C_d	20 to 45 pF
		BA102A (white)	C_d	20 to 25 pF
		BA102B (yellow)	C_d	23 to 31 pF
		BA102C (blue)	C_d	29 to 38 pF
		BA102D (green)	C_d	36 to 45 pF

Capacitance ratio at $f < 300$ MHz

$\frac{C_d (V_R = 4 V)}{C_d (V_R = 10 V)} > 1,4$

Series resistance

$V_R = 4$ V r_D typ. 1,7 Ω
< 3 Ω

Simplified equivalent circuit:

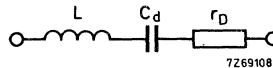

L = lead inductance ≈ 6 nH

r_D = series resistance

C_d = diode capacitance (see page 3)

frequency independent
up to $f = 300$ MHz

These data apply for a distance of 10 mm between the two measuring points.

APPLICATION INFORMATION

Application information available on request.

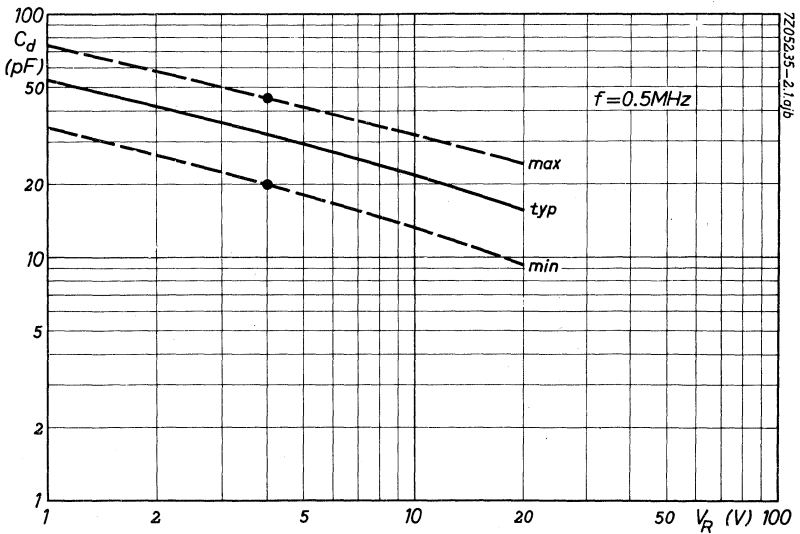
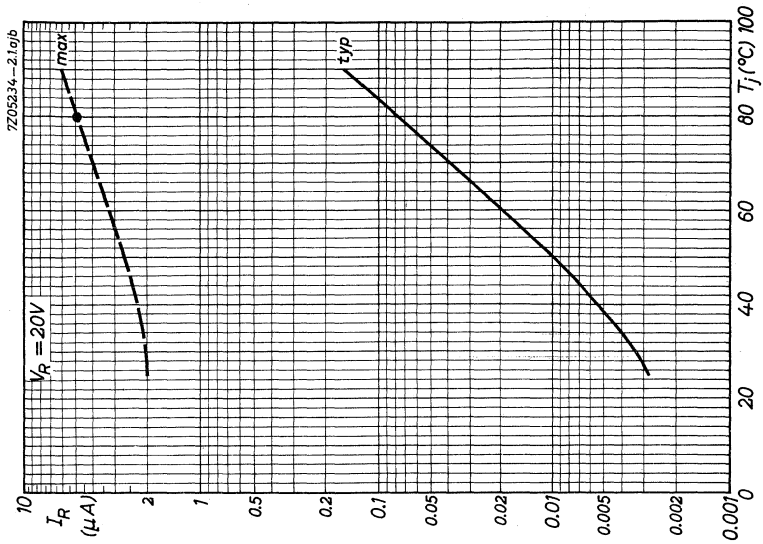

SILICON PLANAR DIODE

The BA182 is a switching diode in a plastic envelope. It is intended for band switching in v.h.f. television tuners.

QUICK REFERENCE DATA			
Continuous reverse voltage	V_R	max.	35 V
Forward current (d. c.)	I_F	max.	100 mA
Junction temperature	T_j	max.	100 °C
Diode capacitance at $f = 1$ MHz $V_R = 20$ V	C_d	typ.	0,8 pF
		<	1,0 pF
Series resistance at $f = 200$ MHz $I_F = 5$ mA	r_D	typ.	0,5 Ω
		<	0,7 Ω

MECHANICAL DATA

Dimensions in mm

SOD-23

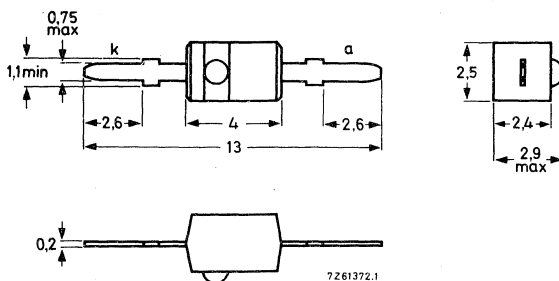

The blue band indicates the cathode

The sealing of the plastic envelope withstands the accelerated damp heat test of IEC recommendation 68 - 2 (test D, severity IV, 6 cycles).

RATINGS (Limiting values) 1)VoltageContinuous reverse voltage V_R max. 35 VCurrentForward current (d.c.) I_F max. 100 mATemperaturesStorage temperature T_{stg} -55 to +100 °CJunction temperature T_j max. 100 °C**THERMAL RESISTANCE**From junction to ambient in free air $R_{th\ j-a}$ = 0.4 °C/mW**CHARACTERISTICS**Forward voltage at $I_F = 100$ mA V_F < 1.2 VReverse current $V_R = 20$ V I_R < 100 nA $V_R = 20$ V; $T_j = 60$ °C I_R < 1 μADiode capacitance at $f = 1$ MHz $V_R = 20$ V C_d typ. 0.8 pF
< 1 pFSeries resistance at $f = 200$ MHz $I_F = 5$ mA r_D typ. 0.5 Ω
< 0.7 Ω

1) Limiting values according to the Absolute Maximum System as defined in IEC publication 134.

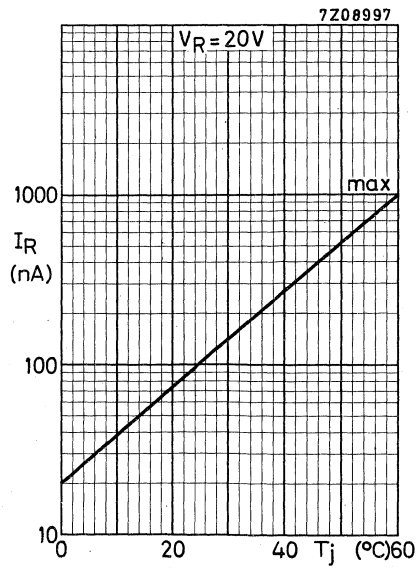
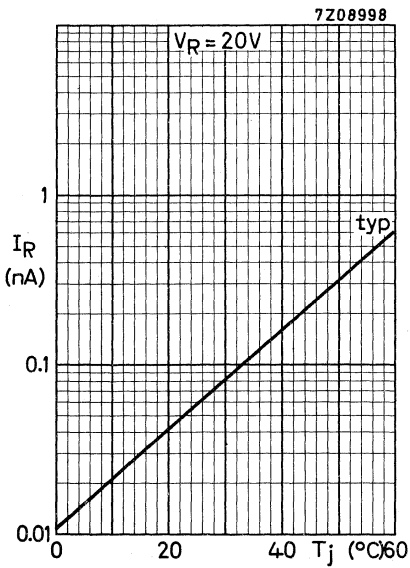
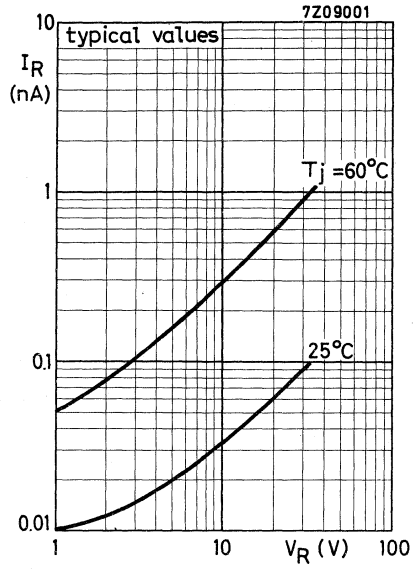
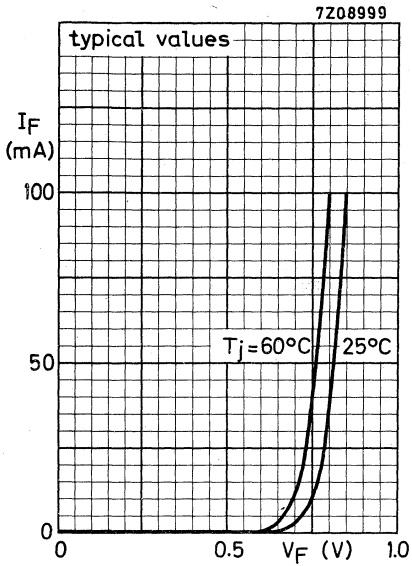

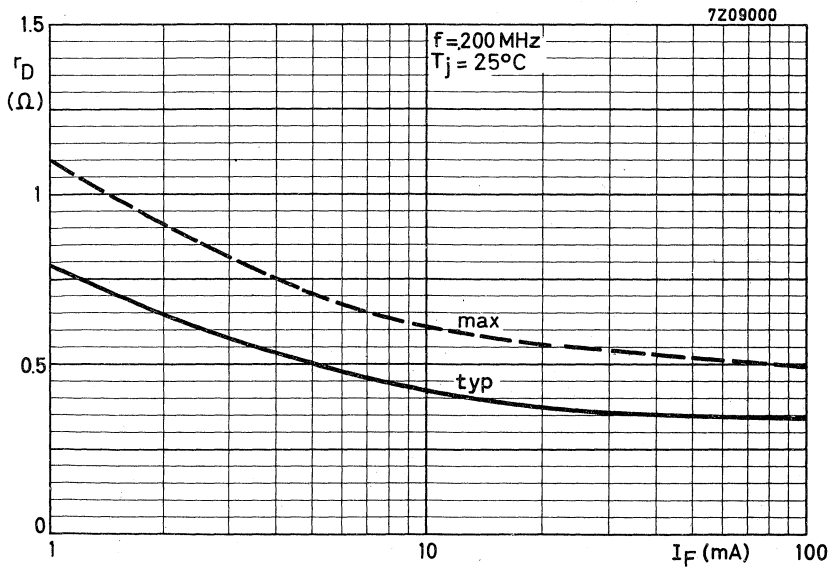
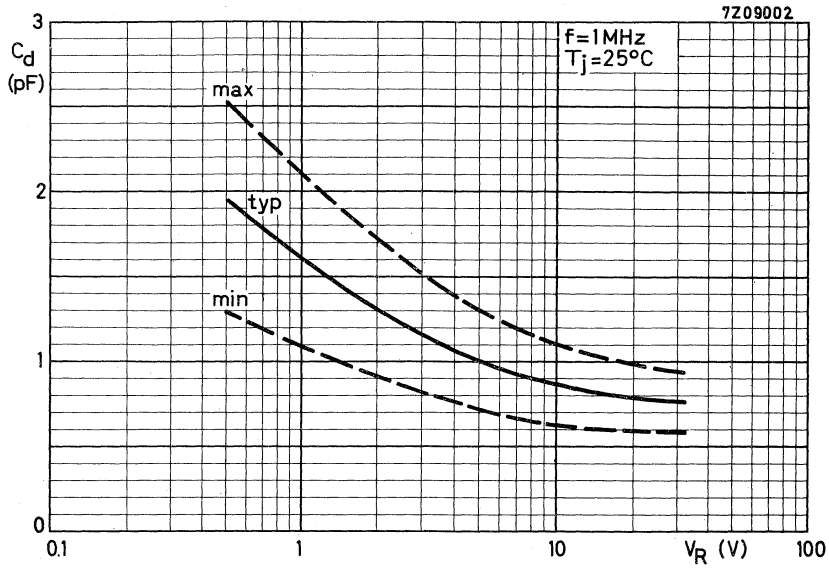

SILICON PLANAR DIODES

Switching diodes in a DO-35 envelope, intended for band switching in v. h. f. television tuners.

QUICK REFERENCE DATA				
Continuous reverse voltage	V_R	max.	20	V
Forward current (d. c.)	I_F	max.	100	mA
Junction temperature	T_j	max.	150	°C
Diode capacitance at $f = 1$ to 100 MHz $V_R = 15$ V	C_d	typ.	1, 1	pF
		<	2	pF
Series resistance at $f = 200$ MHz $I_F = 10$ mA	r_D	typ	0, 7	Ω
		<	1	Ω

MECHANICAL DATA

Dimensions in mm

DO-35

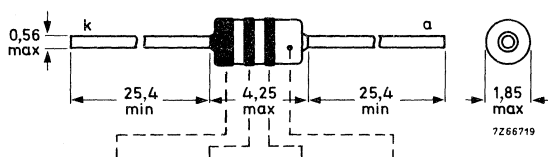

BA243: red yellow orange natural
 (cathode)

BA244: red yellow yellow natural
 (cathode)

RATINGS Limiting values in accordance with the Absolute Maximum System (IEC 134)

Voltage

Continuous reverse voltage V_R max. 20 V

Current

Forward current (d. c.) I_F max. 100 mA

Temperatures

Storage temperature T_{stg} -55 to +150 °C

Junction temperature T_j max. 150 °C

THERMAL RESISTANCE

From junction to ambient in free air $R_{th\ j-a}$ = 0,6 °C/mW

CHARACTERISTICS

$T_j = 25$ °C unless otherwise specified

Forward voltage at $I_F = 100$ mA

V_F < 1 V

Reverse current at $V_R = 15$ V

I_R < 100 nA

$V_R = 15$ V; $T_{amb} = 60$ °C

I_R < 1 µA

Diode capacitance at $f = 1$ to 100 MHz

$V_R = 15$ V

C_d typ. 1,1 pF
< 2 pF

Relative capacitance variation

due to reverse voltage variation
at $V_R = 7$ to 20 V; $f = 1$ to 100 MHz
related to $V_R = 7$ V

$\frac{\Delta C_d}{C_d \cdot \Delta V_R}$ typ. 1 %/V

Series resistance at $f = 200$ MHz

$I_F = 10$ mA

		BA243	BA244
r_D	typ.	0,7	0,4 Ω
	<	1	0,5 Ω

Relative series resistance variation

due to forward current variation
at $I_F = 2$ to 40 mA; $f = 200$ MHz
related to $I_F = 2$ mA

$\frac{\Delta r_D}{r_D \cdot \Delta I_F}$ typ. 2 %/mA

Series inductance (measured on envelope)

L_s typ. 2,5 nH

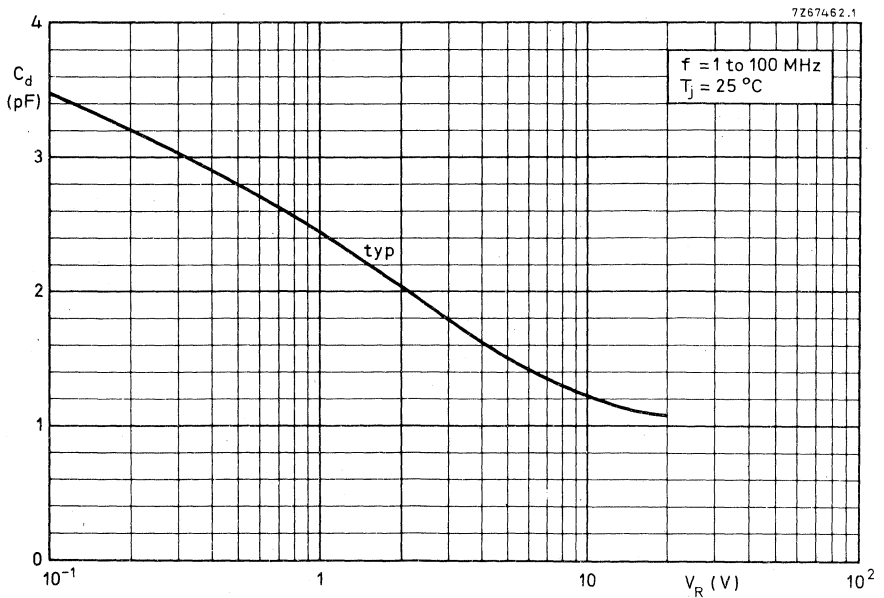
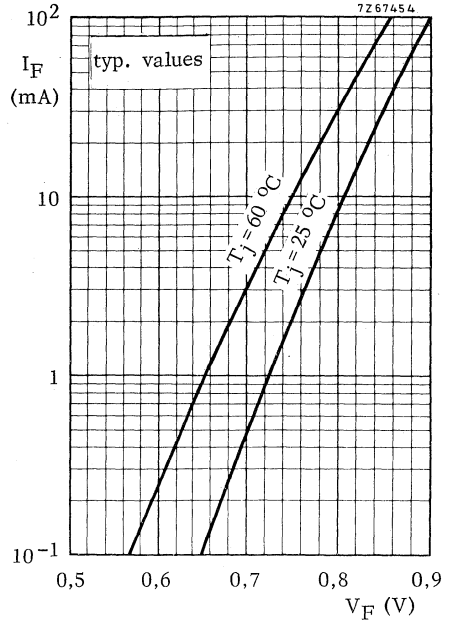
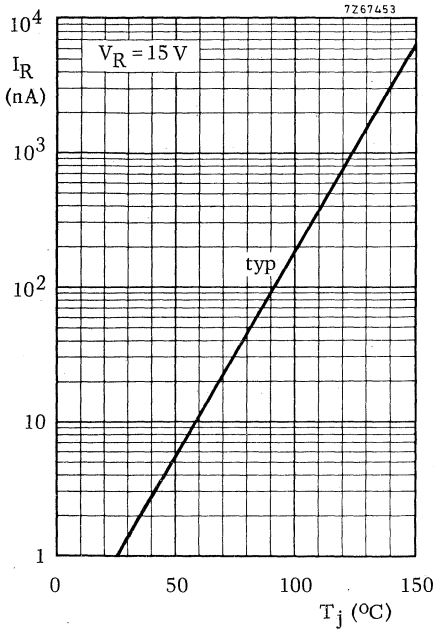

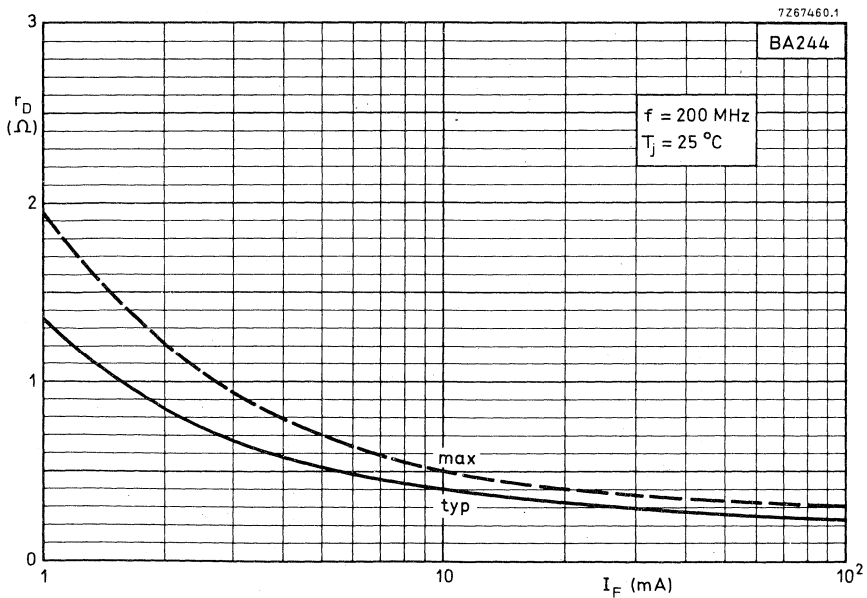
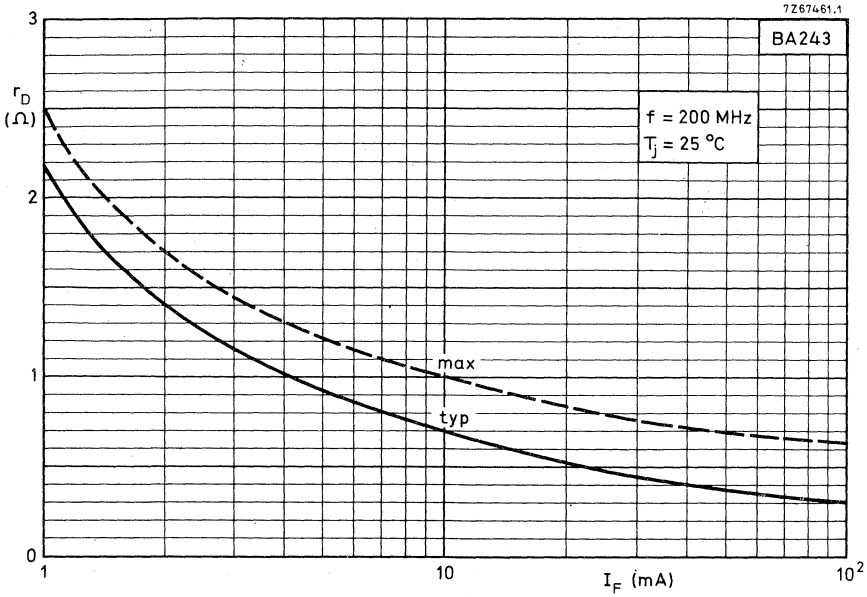

SILICON P-I-N DIODE

Primarily for use in controlled attenuators in v. h. f. and u. h. f. television tuners.

QUICK REFERENCE DATA			
Continuous reverse voltage	V_R	max.	30 V
Forward current (d. c.)	I_F	max.	20 mA
Operating ambient temperature	T_{amb}	max.	60 °C
Diode capacitance $V_R = 0$; $f = 900$ MHz	C_d	typ.	0,3 pF
R. F. forward resistance $I_F = 10 \mu A$; $f = 35$ MHz	r_D	typ.	1,7 k Ω
$I_F = 10$ mA; $f = 35$ MHz	r_D	typ.	4,5 Ω

MECHANICAL DATA

Dimensions in mm

SOD-52

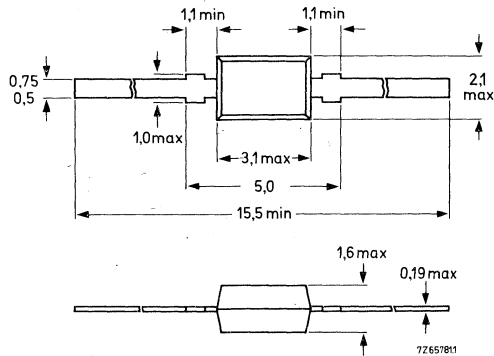

The coloured end indicates the cathode

RATINGS Limiting values in accordance with the Absolute Maximum System (IEC134)

Voltage

Continuous reverse voltage V_R max. 30 V

Current

Forward current (d. c.) I_F max. 20 mA

Temperatures

Storage temperature T_{stg} -55 to +100 °C

Operating ambient temperature T_{amb} max. 60 °C

CHARACTERISTICS at $T_{amb} = 25$ °C

Forward voltage

$I_F = 20$ mA $V_F < 1$ V

Reverse current

$V_R = 10$ V $I_R < 1$ μ A

Diode capacitance

$V_R = 1$ V; $f = 100$ MHz C_d typ. 0,34 pF

$V_R = 0$; $f = 900$ MHz C_d typ. 0,30 pF

R. F. forward resistance

$I_F = 10$ μ A ; $f = 35$ MHz r_D typ. 1,7 k Ω

$I_F = 10$ mA; $f = 35$ MHz r_D typ. 4,5 Ω
< 6,5 Ω

Series inductance 1)

L_s typ. 2 nH

Cross modulation 2)

$f_o = 55$ MHz; $f_{int} = 50$ MHz

$I_F = 50$ μ A V_{int} typ. 0,5 V

1) Measured directly to the envelope.

2) Cross modulation is defined as the interfering voltage with 80% modulation depth over the p-i-n diode, causing 0,8% modulation depth on the wanted signal. (K = 1%)

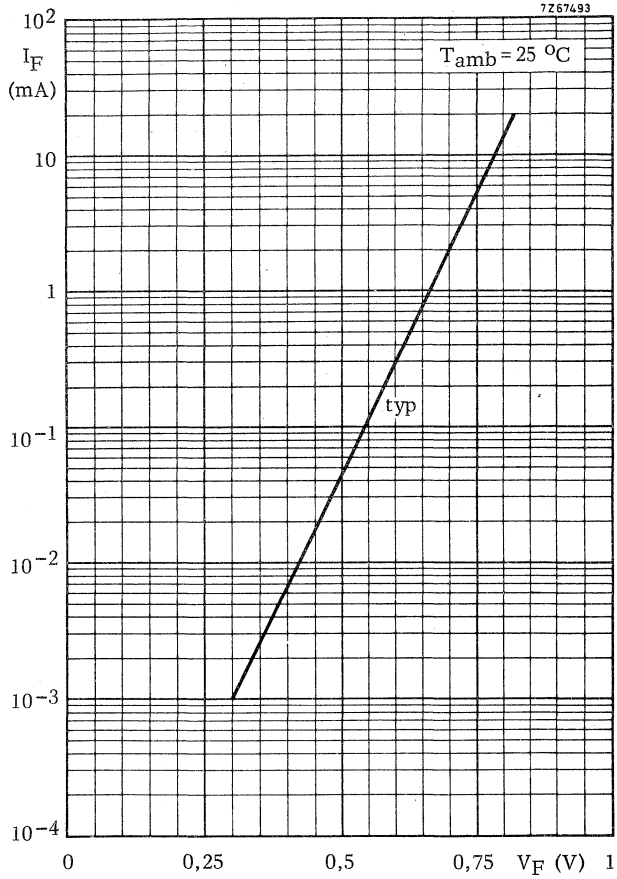

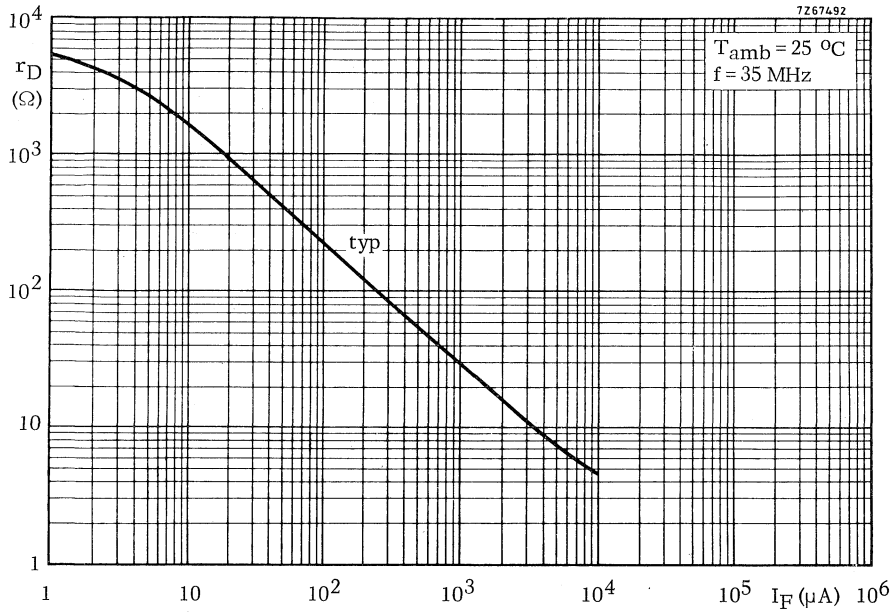

SILICON PLANAR VARIABLE CAPACITANCE DIODES

The BB105A, BB105B and BB105G are variable capacitance diodes in plastic envelopes.

The BB105A is intended for use in u. h. f. tuners up to frequencies of 790 MHz.

The BB105B is meant for u. h. f. tuners up to frequencies of 860 MHz.

The BB105G is meant for v. h. f. tuners.

Diodes will be supplied in matched sets.

The capacitance difference between any two diodes in one set is less than 3% for the BB105A and BB105B, and less than 6% for the BB105G, over the voltage range from 0,5 V to 28 V.

QUICK REFERENCE DATA					
Continuous reverse voltage	V_R	max.	28	V	
Reverse current at $V_R = 28$ V	I_R	<	50	nA	
			BB105A	BB105B	BB105G
Diode capacitance at $f = 1$ MHz $V_R = 25$ V	C_d	>	2,3	2,0	1,8 pF
		<	2,8	2,3	2,8 pF
Capacitance ratio at $f = 1$ MHz	$\frac{C_d(V_R = 3\text{ V})}{C_d(V_R = 25\text{ V})}$	>	4	4,5	4
		<	5	6,0	6
Series resistance at $f = 470$ MHz V_R is that value at which $C_d = 9$ pF	r_D	typ.	0,6	0,7	0,9 Ω
		<	0,8	0,8	1,2 Ω

MECHANICAL DATA

Dimensions in mm

SOD-23

BB105A and BB105B: marked on packing

BB105G : green dot on the envelope

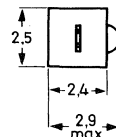
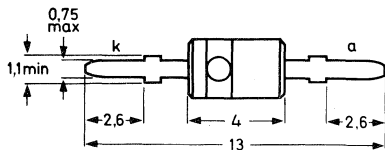

The white band indicates the cathode

The sealing of the plastic envelope withstands the accelerated damp heat test of IEC recommendation 68-2 (test D, severity IV, 6 cycles).

RATINGS Limiting values in accordance with the Absolute Maximum System (IEC134)

Voltages

Continuous reverse voltage	V_R	max.	28	V
Reverse voltage (peak value)	V_{RM}	max.	30	V

Current

Forward current (d. c.)	I_F	max.	20	mA
-------------------------	-------	------	----	----

Temperatures

Storage temperature	T_{stg}	-55 to +100	°C
Operating junction temperature	T_j	max. 60	°C

THERMAL RESISTANCE

From junction to ambient in free air	$R_{th\ j-a}$	=	0,4	°C/mW
--------------------------------------	---------------	---	-----	-------

CHARACTERISTICS

$T_j = 25\ ^\circ\text{C}$ unless otherwise specified

Reverse current

		BB105A	BB105B	BB105G	
$V_R = 28\ \text{V}$	I_R	< 50	50	50	nA
$V_R = 28\ \text{V}; T_j = 60\ ^\circ\text{C}$	I_R	< 500	500	500	nA

Diode capacitance at $f = 1\ \text{MHz}$

$V_R = 1\ \text{V}$	C_d	typ. 17,0	17,5	17,5	pF
$V_R = 3\ \text{V}$	C_d	typ. 11,5	11,5	11,5	pF
$V_R = 25\ \text{V}$	C_d	> 2,3	2,0	1,8	pF
	C_d	< 2,8	2,3	2,8	pF

Capacitance ratio at $f = 1\ \text{MHz}$

$\frac{C_d(V_R = 3\ \text{V})}{C_d(V_R = 25\ \text{V})}$	>	4	4,5	4
	<	5	6,0	6

Series resistance

at $f = 470\ \text{MHz}$ and at that value of V_R at which $C_d = 9\ \text{pF}$	r_D	typ. 0,6	0,7	0,9	Ω
		< 0,8	0,8	1,2	Ω
at $f = 200\ \text{MHz}$ and $I_F = 5\ \text{mA}$	r_D	typ. 0,4	0,4	0,4	Ω

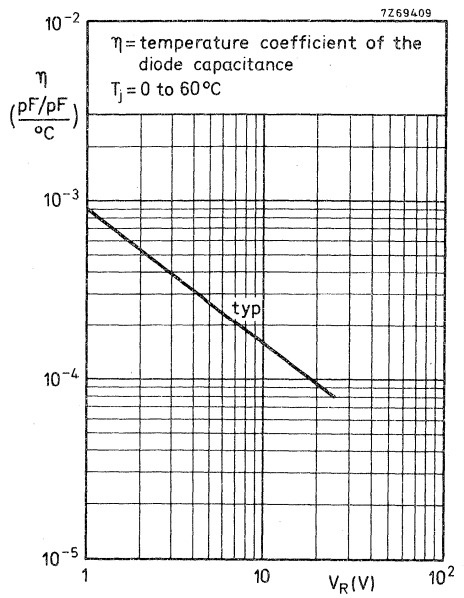
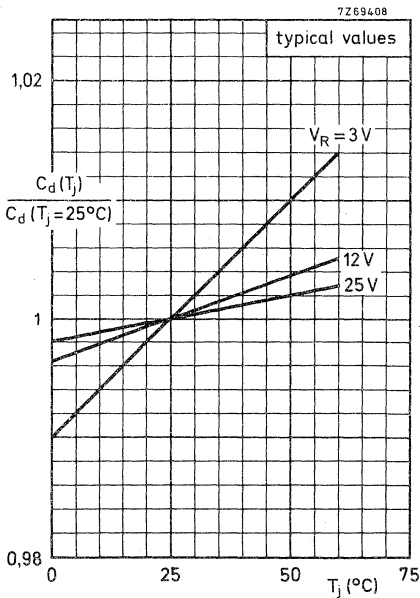
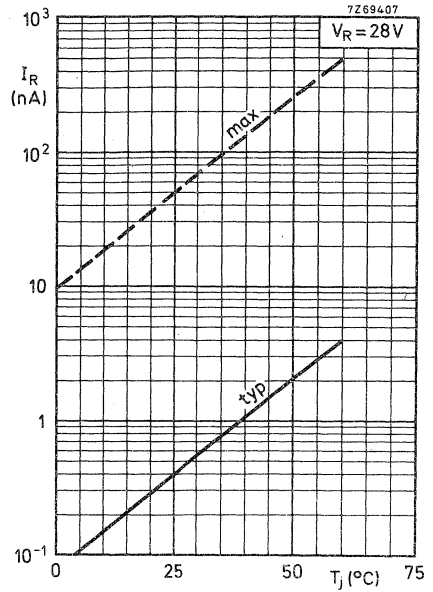
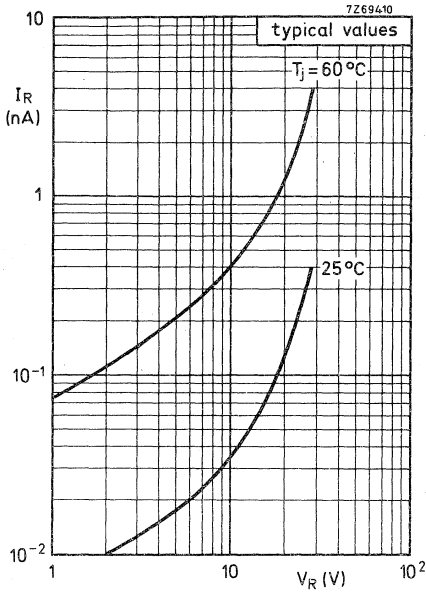

BB105A
BB105B
BB105G

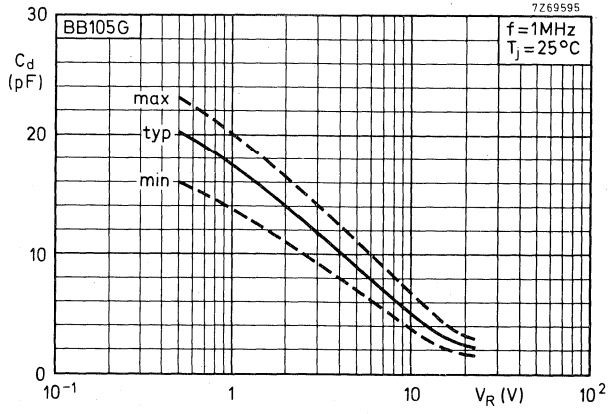
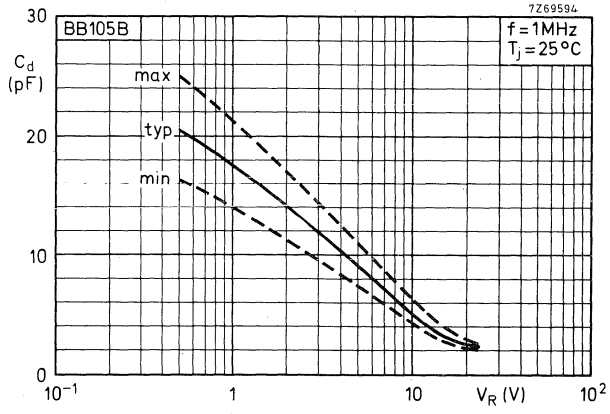
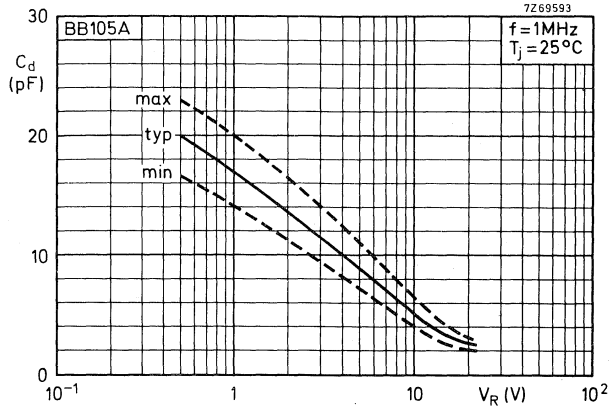

SILICON PLANAR VARIABLE CAPACITANCE DIODE

The BB106 is a variable capacitance diode in a plastic envelope intended for electronic tuning in v. h. f. tuners with extended Band I (FCC norm).

Diodes will be supplied in matched sets.

The capacitance difference between any two diodes in one set is less than 3% over the voltage range from 0,5 V to 28 V.

QUICK REFERENCE DATA			
Continuous reverse voltage	V_R	max.	28 V
Diode capacitance at $f = 0,5$ MHz	$V_R = 3$ V	C_d	> 20 pF
	$V_R = 25$ V	C_d	4,0 to 5,6 pF
Reverse current at $V_R = 28$ V		I_R	< 50 nA
Capacitance ratio at $f = 0,5$ MHz	$C_d (V_R = 3 \text{ V})$		4,5 to 6,0
	$C_d (V_R = 25 \text{ V})$		
Series resistance at $f = 200$ MHz V_R is that value at which $C_d = 25$ pF		r_D	typ. 0,4 Ω
			< 0,6 Ω

MECHANICAL DATA

Dimensions in mm

SOD-23

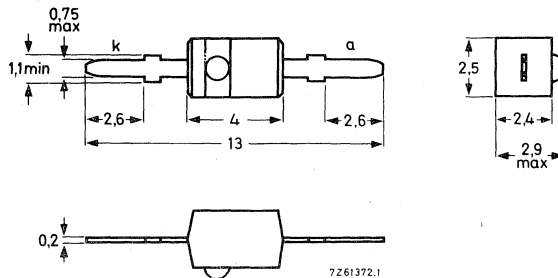

The red band indicates the cathode

The sealing of the plastic envelope withstands the accelerated damp heat test of IEC recommendation 68-2 (test D, severity IV, 6 cycles).

RATINGS Limiting values in accordance with the Absolute Maximum System (IEC134)

Voltages

Continuous reverse voltage	V_R	max.	28	V
Reverse voltage (peak value)	V_{RM}	max.	30	V

Current

Forward current (d. c.)	I_F	max.	20	mA
-------------------------	-------	------	----	----

Temperatures

Storage temperature	T_{stg}	-55 to +100	°C
Operating junction temperature	T_j	max. 60	°C

THERMAL RESISTANCE

From junction to ambient in free air	$R_{th\ j-a}$	=	0,4	°C/mW
--------------------------------------	---------------	---	-----	-------

CHARACTERISTICS

$T_{amb} = 25\ ^\circ\text{C}$ unless otherwise specified

Reverse current

$V_R = 28\ \text{V}$	I_R	<	50	nA
$V_R = 28\ \text{V}; T_{amb} = 60\ ^\circ\text{C}$	I_R	<	200	nA

Series resistance at $f = 200\ \text{MHz}$

V_R is that value at which $C_d = 25\ \text{pF}$	r_D	typ.	0,4	Ω
		<	0,6	Ω

Diode capacitance at $f = 0,5\ \text{MHz}$

$V_R = 3\ \text{V}$	C_d	>	20	pF
$V_R = 25\ \text{V}$	C_d		4,0 to 5,6	pF

Capacitance ratio at $f = 0,5\ \text{MHz}$

$$\frac{C_d(V_R = 3\ \text{V})}{C_d(V_R = 25\ \text{V})} \quad 4,5\ \text{to}\ 6,0$$



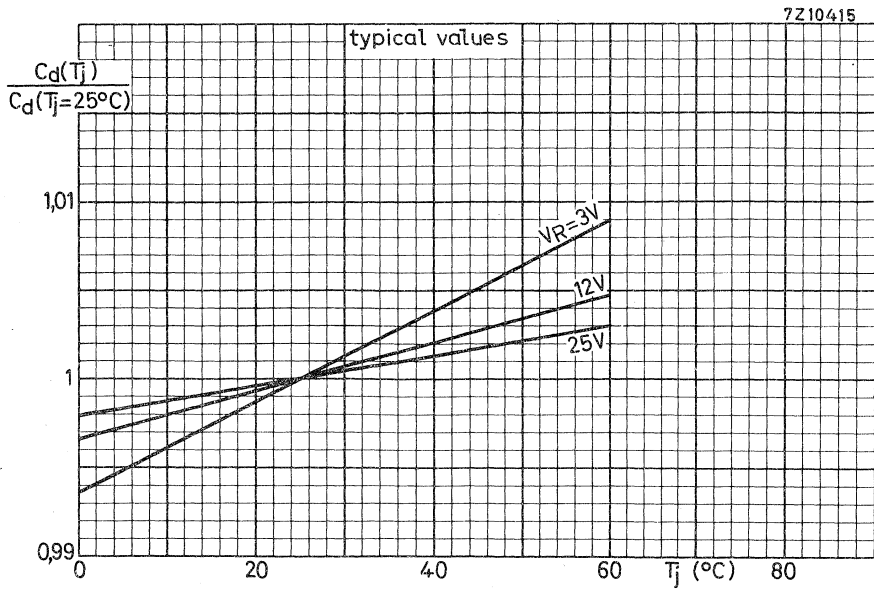
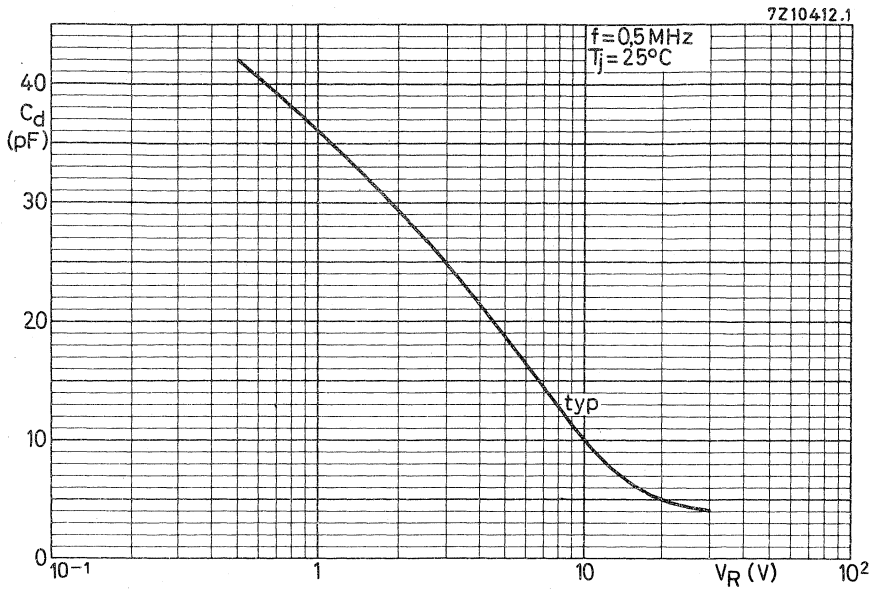

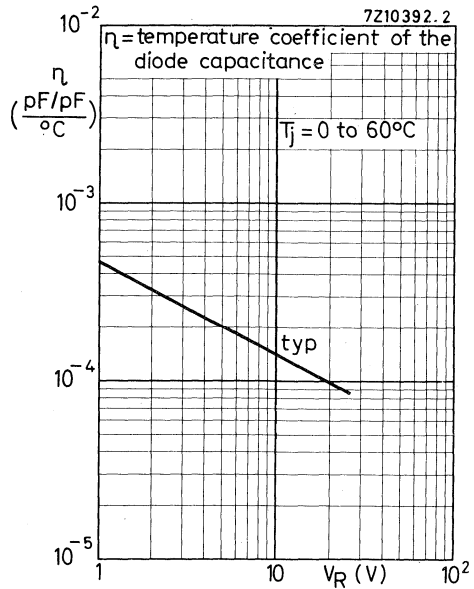
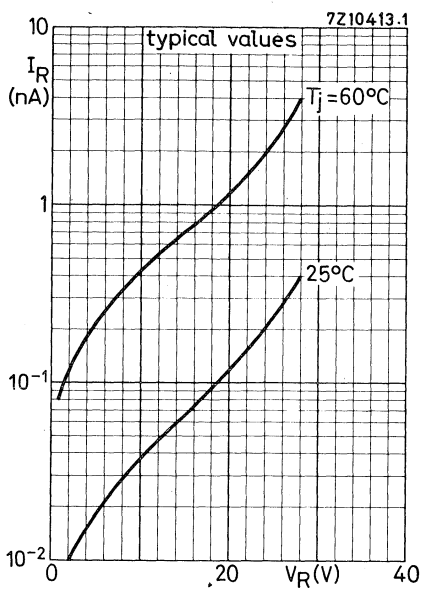
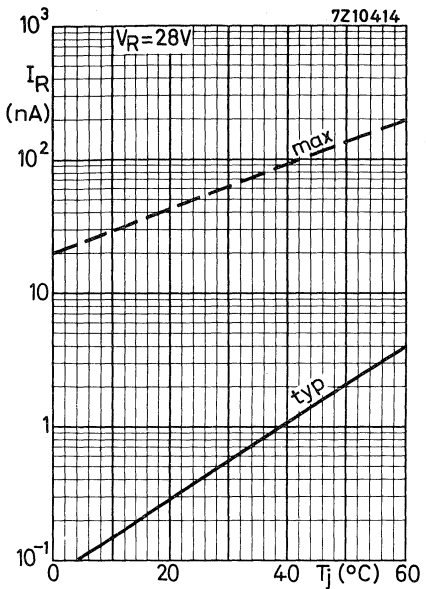

SILICON PLANAR VARIABLE CAPACITANCE DIODES

The BB110B and BB110G are variable capacitance diodes in a plastic envelope primarily intended for electronic tuning in band II (f.m.). They are recommended for r.f. and interstage circuits.

QUICK REFERENCE DATA				
Continuous reverse voltage	V_R	max.	30	V
Junction temperature	T_j	max.	100	$^{\circ}\text{C}$
Reverse current at $V_R = 30\text{ V}$	I_R	<	20	nA
Diode capacitance at $f = 1\text{ MHz}$ $V_R = 3\text{ V}$	C_d	BB110G BB110B		pF
		27 - 31 29 - 33		
Capacitance ratio	$\frac{C_d(V_R = 3\text{ V})}{C_d(V_R = 30\text{ V})}$	typ.	2,65	
Series resistance at $f = 100\text{ MHz}$ V_R is that value at which $C_d = 30\text{ pF}$	r_D	typ.	0,3	Ω
		<	0,4	Ω

MECHANICAL DATA

Dimensions in mm

SOD-23

BB110B: blue dot

BB110G: green dot

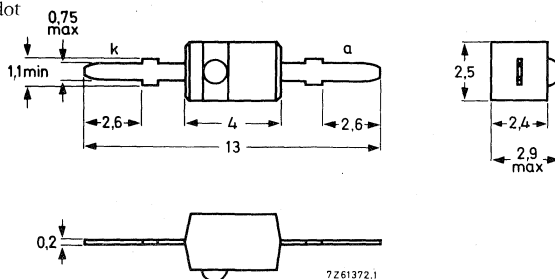

The yellow band indicates the cathode

The sealing of the plastic envelope withstands the accelerated damp heat test of IEC recommendation 68-2 (test D, severity IV, 6 cycles).

RATINGS Limiting values in accordance with the Absolute Maximum System (IEC 134)

Voltage

Continuous reverse voltage V_R max. 30 V

Current

Forward current (d.c.) I_F max. 100 mA

Temperatures

Storage temperature T_{stg} - 55 to +100 °C

Junction temperature T_j max. 100 °C

THERMAL RESISTANCE

From junction to ambient in free air $R_{th\ j-a}$ = 0,4 °C/mW

CHARACTERISTICS

$T_j = 25$ °C unless otherwise specified

Reverse current at $V_R = 30$ V I_R typ. 1 nA
< 20 nA

$V_R = 30$ V; $T_j = 60$ °C I_R typ. 5 nA
< 200 nA

Diode capacitance at $f = 1$ MHz

$V_R = 3$ V C_d BB110G | BB110B
27-31 | 29-33 pF

$V_R = 30$ V C_d typ. 11 pF

Capacitance ratio at $f = 1$ MHz

$\frac{C_d(V_R = 3\text{ V})}{C_d(V_R = 30\text{ V})}$ typ. 2,65

Series resistance at $f = 100$ MHz

V_R is that value at which $C_d = 30$ pF r_D typ. 0,3 Ω
< 0,4 Ω

Temperature coefficient of the diode capacitance

$V_R = 30$ V η typ. 0,04 %/°C

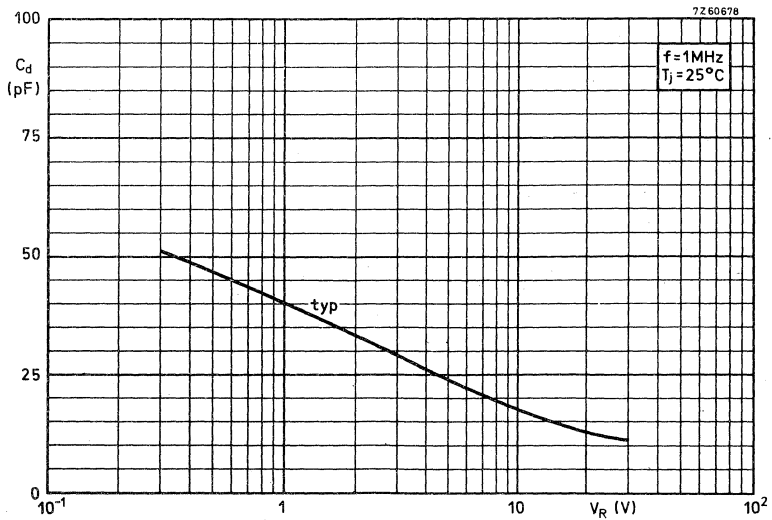
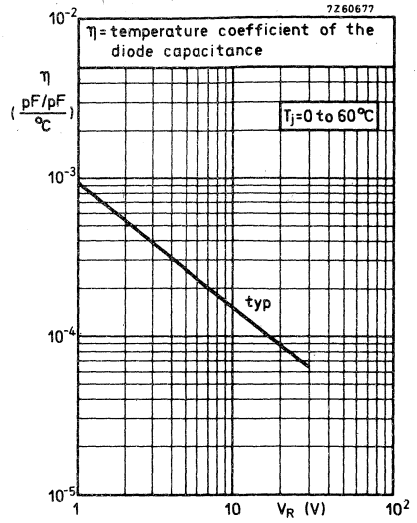
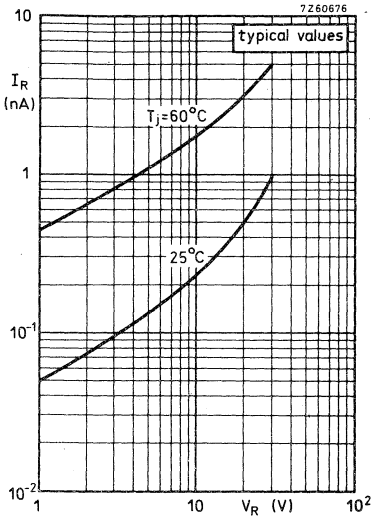

SILICON PLANAR VARIABLE CAPACITANCE DIODE

The BB117 is a variable capacitance diode in a plastic envelope. The diode is primarily intended for automatic frequency control in television receivers.

QUICK REFERENCE DATA				
Reverse voltage	V_R	max.	20	V
Reverse current at $V_R = 20$ V	I_R	<	100	nA
Diode capacitance at $f = 0,5$ MHz $V_R = 15$ V	C_d		2,2 to 4,0	pF
Capacitance ratio	$\frac{C_d(V_R = 4 \text{ V})}{C_d(V_R = 15 \text{ V})}$		2,0 to 5,0	
Series resistance at $f = 470$ MHz V_R is that value at which $C_d = 9$ pF	r_D	<	1,2	Ω

MECHANICAL DATA

Dimensions in mm

SOD-23

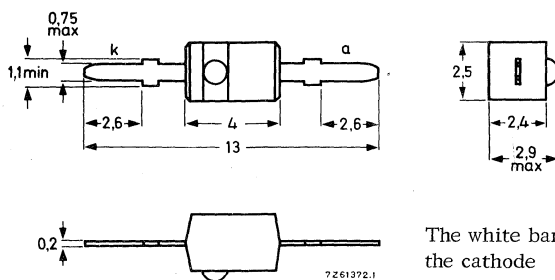

The sealing of the plastic envelope withstands the accelerated damp heat test of IEC recommendation 68-2 (test D, severity IV, 6 cycles) .

RATINGS Limiting values in accordance with the Absolute Maximum System (IEC 134)

Continuous reverse voltage	V_R	max.	20	V
Forward current (d. c.)	I_F	max.	20	mA
Storage temperature	T_{stg}		-55 to +100	°C
Operating junction temperature	T_j	max.	60	°C

THERMAL RESISTANCE

From junction to ambient in free air	$R_{th\ j-a}$	=	0,4	°C/mW
--------------------------------------	---------------	---	-----	-------

CHARACTERISTICS

$T_j = 25\text{ °C}$ unless otherwise specified

Reverse current

$V_R = 20\text{ V}$	I_R	<	100	nA
$V_R = 20\text{ V}; T_j = 60\text{ °C}$	I_R	<	500	nA

Diode capacitance at $f = 0,5\text{ MHz}$

$V_R = 4\text{ V}$	C_d		8 to 11	pF
$V_R = 15\text{ V}$	C_d		2,2 to 4,0	pF

Capacitance ratio at $f = 0,5\text{ MHz}$

$\frac{C_d(V_R = 4\text{ V})}{C_d(V_R = 15\text{ V})}$			2,0 to 5,0	
--	--	--	------------	--

Series resistance at $f = 470\text{ MHz}$

V_R is that value at which $C_d = 9\text{ pF}$	r_D	<	1,2	Ω
--	-------	---	-----	---



SILICON PLANAR VARIABLE CAPACITANCE DOUBLE DIODES

The BB204B and BB204G are double diodes with common cathode in a plastic TO-92 variant, primarily intended for electronic tuning in band II (f. m.). They are recommended for stages where large signals occur (e.g. oscillator circuits).

QUICK REFERENCE DATA								
For each diode:								
Continuous reverse voltage	V_R	max.	30	V				
Junction temperature	T_j	max.	100	°C				
Reverse current at $V_R = 30$ V	I_R	<	50	nA				
Diode capacitance at $f = 1$ MHz $V_R = 3$ V	C_d		<table border="1" style="display: inline-table; border-collapse: collapse;"> <tr> <td style="text-align: center;">BB204G</td> <td style="text-align: center;">BB204B</td> </tr> <tr> <td style="text-align: center;">34 - 39</td> <td style="text-align: center;">37 - 42</td> </tr> </table>	BB204G	BB204B	34 - 39	37 - 42	pF
BB204G	BB204B							
34 - 39	37 - 42							
Capacitance ratio at $f = 1$ MHz	$\frac{C_d(V_R = 3\text{ V})}{C_d(V_R = 30\text{ V})}$	typ.	2,65					
Series resistance at $f = 100$ MHz V_R is that value at which $C_d = 38$ pF	r_D	typ.	0,2	Ω				
		<	0,4	Ω				

MECHANICAL DATA

Dimensions in mm

TO-92 variant

BB204B: blue type marking

BB204G: green type marking

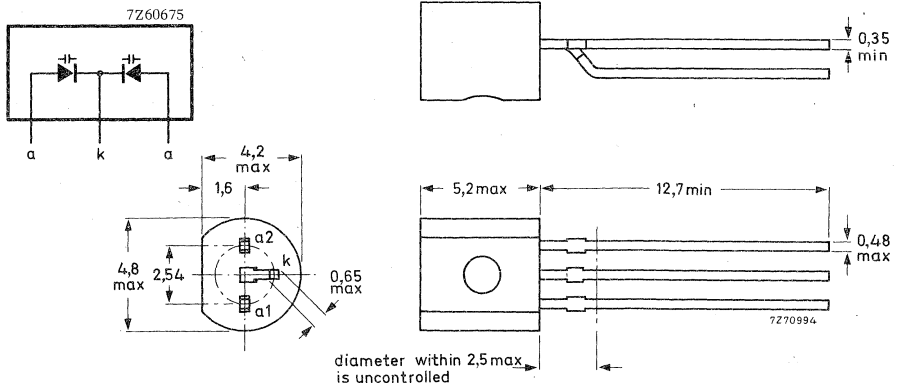

RATINGS Limiting values in accordance with the Absolute Maximum System (IEC134)

For each diode:

Voltage

Continuous reverse voltage V_R max. 30 V

Current

Forward current (d. c.) I_F max. 100 mA

Temperatures

Storage temperature T_{stg} -55 to +100 °C

Junction temperature T_j max. 100 °C

CHARACTERISTICS (for each diode)

Reverse current at $V_R = 30$ V I_R < 50 nA

Diode capacitance at $f = 1$ MHz

$V_R = 3$ V	C_d			
		BB204G	BB204B	
		34 - 39	37 - 42	pF

$V_R = 30$ V	C_d	typ.	14	pF
--------------	-------	------	----	----

Capacitance ratio at $f = 1$ MHz $\frac{C_d (V_R = 3 \text{ V})}{C_d (V_R = 30 \text{ V})}$ typ. 2,65

Series resistance at $f = 100$ MHz

V_R is that value at which $C_d = 38$ pF r_D typ. 0,2 Ω
< 0,4 Ω



SILICON PLANAR VARIABLE CAPACITANCE DIODES

The BB205A is intended for use in u. h. f. tuners up to frequencies of 790 MHz.

The BB205B is meant for u. h. f. tuners up to frequencies of 860 MHz.

The BB205G is meant for v. h. f. tuners.

Diodes will be supplied in matched sets.

The capacitance difference between any diode in one set is less than 3% over the voltage range from 0,5 V to 28 V.

QUICK REFERENCE DATA					
Continuous reverse voltage	V_R max.	28	V		
Reverse current at $T_j = 25^\circ\text{C}$ $V_R = 28\text{ V}$	I_R <	50	nA		
Diode capacitance at $f = 500\text{ kHz}$ $V_R = 25\text{ V}$	C_d >	BB205A	BB205B	BB205G	
		<	2,1	1,9	1,8
Capacitance ratio at $f = 500\text{ kHz}$	$\frac{C_d(V_R = 3\text{ V})}{C_d(V_R = 25\text{ V})}$ >	4,3	5,0	4,3	
	<	5,3	6,0	6,0	
Series resistance at $f = 470\text{ MHz}$ V_R is that value at which $C_d = 9\text{ pF}$	r_D typ.	0,6	0,7	0,9	Ω
		<	0,8	0,8	1,2

MECHANICAL DATA

Dimensions in mm

SOD-23

BB205A; BB205B: marked on packing

BB205G : green dot on the envelope

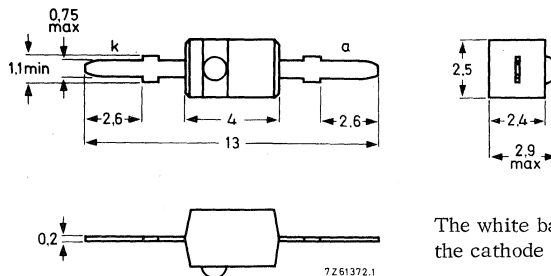

The white band indicates the cathode

The sealing of the plastic envelope withstands the accelerated damp heat test of IEC recommendation 68-2 (test D, severity IV, 6 cycles).

RATINGS Limiting values in accordance with the Absolute Maximum System (IEC134)

Continuous reverse voltage	V_R	max.	28	V
Reverse voltage (peak value)	V_{RM}	max.	30	V
Forward current (d. c.)	I_F	max.	20	mA
Storage temperature	T_{stg}		-55 to +100	°C
Operating junction temperature	T_j	max.	60	°C

THERMAL RESISTANCE

From junction to ambient in free air	$R_{th\ j-a}$	=	0,4	°C/mW
--------------------------------------	---------------	---	-----	-------

CHARACTERISTICS

$T_j = 25\text{ °C}$ unless otherwise specified

Reverse current

			BB205A	BB205B	BB205G	
$V_R = 28\text{ V}$	I_R	<	50	50	50	nA
$V_R = 28\text{ V}; T_j = 60\text{ °C}$	I_R	<	500	500	500	nA

Diode capacitance at $f = 500\text{ kHz}$

			BB205A	BB205B	BB205G	
$V_R = 1\text{ V}$	C_d	typ.	17	17	17	pF
$V_R = 3\text{ V}$	C_d	typ.	11	11	11	pF
$V_R = 25\text{ V}$	C_d	>	2,1	1,9	1,8	pF
		<	2,5	2,2	2,6	pF

Capacitance ratio at $f = 500\text{ kHz}$

			BB205A	BB205B	BB205G
$\frac{C_d(V_R = 3\text{ V})}{C_d(V_R = 25\text{ V})}$	>		4,3	5,0	4,3
	<		5,3	6,0	6,0

Series resistance

			BB205A	BB205B	BB205G	
at $f = 470\text{ MHz}$ and at that value of V_R at which $C_d = 9\text{ pF}$	r_D	typ.	0,6	0,7	0,9	Ω
		<	0,8	0,8	1,2	Ω
at $f = 200\text{ MHz}$ and $I_F = 5\text{ mA}$	r_D	typ.	0,4	0,4	0,4	Ω



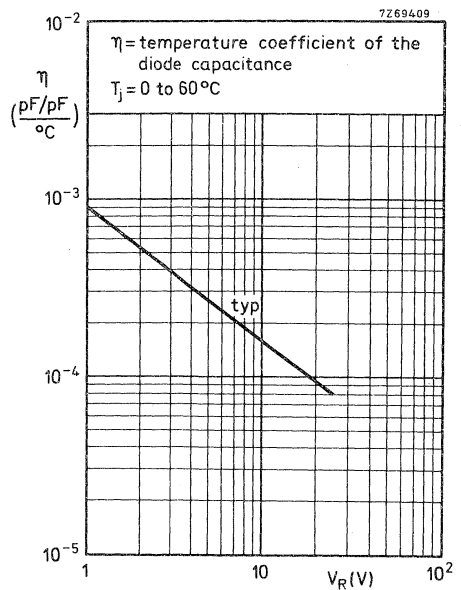
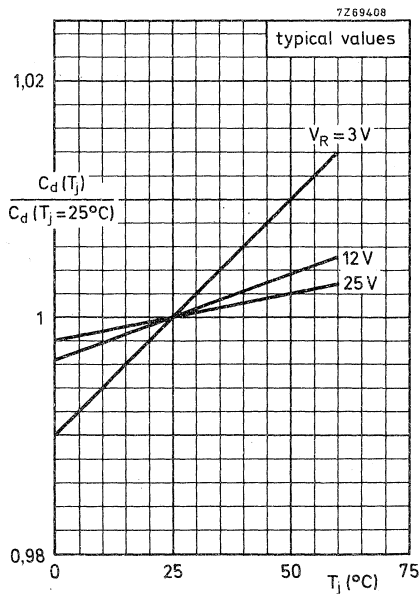
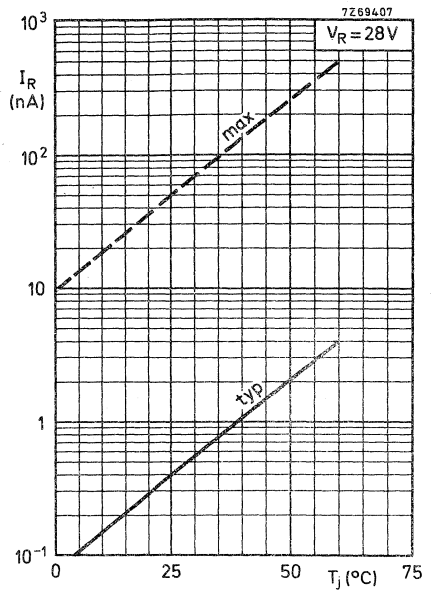
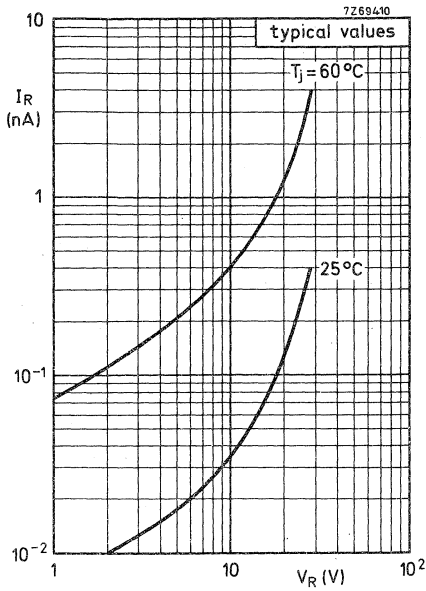

INDEX OF TYPE NUMBERS

The inclusion of a type number in this publication does not necessarily imply its availability.

Type No.	Part	Section	Type No.	Part	Section	Type No.	Part	Section
AA119	1b	PC	AF369	3	HF	BA315	1b	Vrg
AAY21	1b	PC	ASY26	3	Sw	BA316	1b	WD
AAY30	1b	GB	ASY27	3	Sw	BA317	1b	WD
AAY32	1b	GB	ASY28	3	Sw	BA318	1b	WD
AAZ13	1b	GB	ASY29	3	Sw	BA379	1b	T
AAZ15	1b	GB	ASY73	3	Sw	BAV10	1b	WD
AAZ17	1b	GB	ASY74	3	Sw	BAV18	1b	WD
AAZ18	1b	GB	ASY75	3	Sw	BAV19	1b	WD
AC125	2	LF	ASY76	3	Sw	BAV20	1b	WD
AC126	2	LF	ASY77	3	Sw	BAV21	1b	WD
AC127	2	LF	ASY80	3	Sw	BAV45	1b	Sp
AC127/01	2	LF	ASZ15	2	P	BAV70	4a	Mm
AC128	2	LF	ASZ16	2	P	BAV99	4a	Mm
AC128/01	2	LF	ASZ17	2	P	BAW56	4a	Mm
AC132	2	LF	ASZ18	2	P	BAW62	1b	WD
AC132/01	2	LF	BA100	1b	AD	BAX12	1b	WD
AC187	2	LF	BA102	1b	T	BAX13	1b	WD
AC187/01	2	LF	BA145	1a	R	BAX14	1b	WD
AC188	2	LF	BA148	1a	R	BAX15	1b	WD
AC188/01	2	LF	BA182	1b	T	BAX16	1b	WD
AD161	2	P	BA216	1b	WD	BAX17	1b	WD
AD162	2	P	BA217	1b	WD	BAX18	1b	WD
AF124	3	HF	BA218	1b	WD	BB105A	1b	T
AF125	3	HF	BA219	1b	WD	BB105B	1b	T
AF126	3	HF	BA220	1b	WD	BB105G	1b	T
AF127	3	HF	BA221	1b	WD	BB106	1b	T
AF139	3	HF	BA222	1b	WD	BB110B	1b	T
AF239	3	HF	BA243	1b	T	BB110G	1b	T
AF239S	3	HF	BA244	1b	T	BB117	1b	T
AF367	3	HF	BA314	1b	Vrg	BB204B	1b	T

AD = Silicon alloyed diodes
 GB = Germanium gold bonded diodes
 HF = High frequency transistors
 LF = Low frequency transistors
 Mm = Microminiature devices for
 thick- and thin-film circuits
 P = Low frequency power transistors

PC = Germanium point contact diodes
 R = Rectifier diodes
 Sp = Special diodes
 Sw = Switching transistors
 T = Tuner diodes
 Vrg = Voltage regulator diodes
 WD = Silicon whiskerless diodes

INDEX

Type No.	Part	Section	Type No.	Part	Section	Type No.	Part	Section
BB204G	1b	T	BC559	2	LF	BCY89	4a	DT
BB205A	1b	T	BC635	2	LF	BD115	2	P
BB205B	1b	T	BC636	2	LF	BD131	2	P
BB205G	1b	T	BC637	2	LF	BD132	2	P
BBY 31	4a	Mm	BC638	2	LF	BD133	2	P
BC107	2	LF	BC639	2	LF	BD135	2	P
BC108	2	LF	BC640	2	LF	BD136	2	P
BC109	2	LF	BCW29	4a	Mm	BD137	2	P
BC146	2	LF	BCW30	4a	Mm	BD138	2	P
BC147	2	LF	BCW31	4a	Mm	BD139	2	P
BC148	2	LF	BCW32	4a	Mm	BD140	2	P
BC149	2	LF	BCW33	4a	Mm	BD181	2	P
BC157	2	LF	BCW69	4a	Mm	BD182	2	P
BC158	2	LF	BCW70	4a	Mm	BD183	2	P
BC159	2	LF	BCW71	4a	Mm	BD201	2	P
BC177	2	LF	BCW72	4a	Mm	BD202	2	P
BC178	2	LF	BCX17	4a	Mm	BD203	2	P
BC179	2	LF	BCX18	4a	Mm	BD204	2	P
BC200	2	LF	BCX19	4a	Mm	BD226	2	P
BC264A	4a	FET	BCX20	4a	Mm	BD227	2	P
BC264B	4a	FET	BCY30	2	LF	BD228	2	P
BC264C	4a	FET	BCY31	2	LF	BD229	2	P
BC264D	4a	FET	BCY32	2	LF	BD230	2	P
BC327	2	LF	BCY33	2	LF	BD231	2	P
BC328	2	LF	BCY34	2	LF	BD232	2	P
BC337	2	LF	BCY55	4a	DT	BD233	2	P
BC338	2	LF	BCY56	2	LF	BD234	2	P
BC546	2	LF	BCY57	2	LF	BD235	2	P
BC547	2	LF	BCY58	2	LF	BD236	2	P
BC548	2	LF	BCY59	2	LF	BD237	2	P
BC549	2	LF	BCY70	2	LF	BD238	2	P
BC550	2	LF	BCY71	2	LF	BD262	2	P
BC556	2	LF	BCY72	2	LF	BD262A	2	P
BC557	2	LF	BCY87	4a	DT	BD262B	2	P
BC558	2	LF	BCY88	4a	DT	BD263	2	P

DT = Dual transistors

FET = Field-effect transistors

LF = Low frequency transistors

Mm = Microminiature devices for
thick- and thin-film circuits

P = Low frequency power transistors

T = Tuner diodes

Type No.	Part	Section	Type No.	Part	Section	Type No.	Part	Section
BD263A	2	P	BF 167	3	HF	BF450	3	HF
BD263B	2	P	BF 173	3	HF	BF451	3	HF
BD291	2	P	BF 177	3	HF	BF457	3	HF
BD292	2	P	BF 178	3	HF	BF458	3	HF
BD293	2	P	BF 179	3	HF	BF459	3	HF
BD294	2	P	BF 180	3	HF	BF480	3	HF
BD433	2	P	BF 181	3	HF	BF494	3	HF
BD434	2	P	BF 182	3	HF	BF495	3	HF
BD435	2	P	BF 183	3	HF	BFQ 10	4a	FET
BD436	2	P	BF 184	3	HF	BFQ 11	4a	FET
BD437	2	P	BF 185	3	HF	BFQ 12	4a	FET
BD438	2	P	BF 194	3	HF	BFQ 13	4a	FET
BDX62	2	P	BF 195	3	HF	BFQ 14	4a	FET
BDX62A	2	P	BF 196	3	HF	BFQ 15	4a	FET
BDX62B	2	P	BF 197	3	HF	BFQ 16	4a	FET
BDX63	2	P	BF 198	3	HF	BFR29	4a	FET
BDX63A	2	P	BF 199	3	HF	BFR30	4a	Mm
BDX63B	2	P	BF200	3	HF	BFR31	4a	Mm
BDX64	2	P	BF240	3	HF	BFR53	4a	Mm
BDX64A	2	P	BF241	3	HF	BFR63	3	HF
BDX64B	2	P	BF244A	4a	FET	BFR64	3	HF
BDX65	2	P	BF244B	4a	FET	BFR65	3	HF
BDX65A	2	P	BF244C	4a	FET	BFR90	3	HF
BDX65B	2	P	BF245A	4a	FET	BFR91	3	HF
BDX77	2	P	BF245B	4a	FET	BFR92	4a	Mm
BDX78	2	P	BF245C	4a	FET	BFR93	4a	Mm
BDY20	2	P	BF256A	4a	FET	BFR94	3	HF
BDY90	2	P	BF256B	4a	FET	BFS17	4a	Mm
BDY91	2	P	BF256C	4a	FET	BFS18	4a	Mm
BDY92	2	P	BF324	3	HF	BFS19	4a	Mm
BDY93	2	P	BF336	3	HF	BFS20	4a	Mm
BDY94	2	P	BF337	3	HF	BFS21	4a	FET
BDY96	2	P	BF338	3	HF	BFS21A	4a	FET
BDY97	2	P	BF362	3	HF	BFS22A	4a	Tr
BF 115	3	HF	BF363	3	HF	BFS23A	4a	Tr

FET = Field-effect transistors
 HF = High frequency transistors
 Mm = Microminiature devices for
 thick- and thin-film circuits

P = Low frequency power transistors
 Tr = Transmitting transistors

INDEX

Type No.	Part	Section	Type No.	Part	Section	Type No.	Part	Section
BFS28	4a	FET	BLX68	4a	Tr	BSS28	3	Sw
BFS92	3	HF	BLX69	4a	Tr	BSS29	3	Sw
BFS93	3	HF	BLX91	4a	Tr	BSS40	3	Sw
BFS94	3	HF	BLX92	4a	Tr	BSS41	3	Sw
BFS95	3	HF	BLX93	4a	Tr	BSS50	3	Sw
BFT24	3	HF	BLX94A	4a	Tr	BSS51	3	Sw
BFT25	3	Mm	BLX95	4a	Tr	BSS52	3	Sw
BFW10	4a	FET	BLX96	4a	Tr	BSV15	3	Sw
BFW11	4a	FET	BLX97	4a	Tr	BSV16	3	Sw
BFW12	4a	FET	BLY83	4a	Tr	BSV17	3	Sw
BFW13	4a	FET	BLY84	4a	Tr	BSV52	4a	Mm
BFW16A	3	HF	BLY87A	4a	Tr	BSV64	3	Sw
BFW17A	3	HF	BLY88A	4a	Tr	BSV68	3	Sw
BFW30	3	HF	BLY89A	4a	Tr	BSV78	4a	FET
BFW45	3	HF	BLY90	4a	Tr	BSV79	4a	FET
BFW61	4a	FET	BLY91A	4a	Tr	BSV80	4a	FET
BFW92	3	HF	BLY92A	4a	Tr	BSV81	4a	FET
BFW93	3	HF	BLY93A	4a	Tr	BSW41	3	Sw
BFX34	3	Sw	BLY94	4a	Tr	BSW66	3	Sw
BFX44	3	HF	BPX25	4b	PDT	BSW67	3	Sw
BFX89	3	HF	BPX29	4b	PDT	BSW68	3	Sw
BFY50	3	HF	BPX40	4b	PDT	BSX19	3	Sw
BFY51	3	HF	BPX41	4b	PDT	BSX20	3	Sw
BFY52	3	HF	BPX42	4b	PDT	BSX21	3	Sw
BFY55	3	HF	BPX66P	4b	PDT	BSX59	3	Sw
BFY90	3	HF	BPX70	4b	PDT	BSX60	3	Sw
BG1895-541	1a	R	BPX71	4b	PDT	BSX61	3	Sw
BG1895-641	1a	R	BPX72	4b	PDT	BT128series	1a	Th
BLW60	4a	Tr	BPX95	4b	PDT	BT129series	1a	Th
BLX13	4a	Tr	BR100	1a	Th	BTW23series	1a	Th
BLX14	4a	Tr	BR101	3	Sw	BTW24series	1a	Th
BLX15	4a	Tr	BRY39	1a	Th	BTW30series	1a	Th
BLX65	4a	Tr	BRY39(SCS)	3	Sw	BTW31series	1a	Th
BLX66	4a	Tr	BRY39(PUT)	3	Sw	BTW32series	1a	Th
BLX67	4a	Tr	BSS27	3	Sw	BTW33series	1a	Th

FET = Field-effect transistors
 HF = High frequency transistors
 Mm = Microminiature devices for
 thick- and thin-film circuits
 PDT = Photodiodes or transistors

R = Rectifier diodes
 Sw = Switching transistors
 Th = Thyristors, diacs, triacs
 Tr = Transmitting transistors

Type No.	Part	Section	Type No.	Part	Section	Type No.	Part	Section
BTW34series	1a	Th	BYX29series	1a	R	BZX87series	1b	Vrg
BTW47series	1a	Th	BYX30series	1a	R	BZX90	1b	Vrf
BTW92series	1a	Th	BYX32series	1a	R	BZX91	1b	Vrf
BTX18series	1a	Th	BYX35	1a	R	BZX92	1b	Vrf
BTX41series	1a	Th	BYX36series	1a	R	BZX93	1b	Vrf
BTX94series	1a	Th	BYX38series	1a	R	BZY78	1b	Vrf
BTX95series	1a	Th	BYX39series	1a	R	BZY88series	1b	Vrg
BTY79series	1a	Th	BYX40series	1a	R	BZY91series	1a	Vrg
BTY87series	1a	Th	BYX42series	1a	R	BZY93series	1a	Vrg
BTY91series	1a	Th	BYX45series	1a	R	BZY95series	1a	Vrg
BU105	2	P	BYX46series	1a	R	BZY96series	1a	Vrg
BU108	2	P	BYX48series	1a	R	BZZ14	1a	Vrg
BU126	2	P	BYX49series	1a	R	BZZ15	1a	Vrg
BU132	2	P	BYX50series	1a	R	BZZ16	1a	Vrg
BU133	2	P	BYX52series	1a	R	BZZ17	1a	Vrg
BU204	2	P	BYX55series	1a	R	BZZ18	1a	Vrg
BU205	2	P	BYX56series	1a	R	BZZ19	1a	Vrg
BU206	2	P	BYX71series	1a	R	BZZ20	1a	Vrg
BU207	2	P	BYX90series	1a	R	BZZ21	1a	Vrg
BU208	2	P	BYX91series	1a	R	BZZ22	1a	Vrg
BU209	2	P	BZV10	1b	Vrf	BZZ23	1a	Vrg
BY126	1a	R	BZV11	1b	Vrf	BZZ24	1a	Vrg
BY127	1a	R	BZV12	1b	Vrf	BZZ25	1a	Vrg
BY164	1a	R	BZV13	1b	Vrf	BZZ26	1a	Vrg
BY176	1a	R	BZV14	1b	Vrf	BZZ27	1a	Vrg
BY179	1a	R	BZV38	1b	Vrf	BZZ28	1a	Vrg
BY184	1a	R	BZW86series	1a	TS	BZZ29	1a	Vrg
BY187	1a	R	BZW91series	1a	TS	CNY22	4b	PhC
BY188	1a	R	BZW93series	1a	TS	CNY23	4b	PhC
BY206	1a	R	BZX55series	1b	Vrg	CNY42	4b	PhC
BY207	1a	R	BZX61series	1b	Vrg	CNY43	4b	PhC
BY209	1a	R	BZX70series	1a	Vrg	CNY44	4b	PhC
BYX10	1a	R	BZX75series	1b	Vrg	CNY46	4b	PhC
BYX22series	1a	R	BZX79series	1b	Vrg	CNY47	4b	PhC
BYX25series	1a	R	BZX84series	4a	Mm	CNY47A	4b	PhC

Mm = Microminiature devices for
thick- and thin-film circuits
P = Low frequency power transistors
PhC = Photocouplers
R = Rectifier diodes

Th = Thyristors, diacs, triacs
TS = Transient suppressor diodes
Vrf = Voltage reference diodes
Vrg = Voltage regulator diodes

INDEX

Type No.	Part	Section	Type No.	Part	Section	Type No.	Part	Section
CQY11B	4b	LED	OSS9210	1a	St	1N5733B	1b	Vrg
CQY24	4b	LED	OSS9310	1a	St	1N5734B	1b	Vrg
CQY46	4b	LED	OSS9410	1a	St	1N5735B	1b	Vrg
CQY47	4b	LED	RPY18	4b	Ph	1N5736B	1b	Vrg
CQY50	4b	LED	RPY19	4b	Ph	1N5737B	1b	Vrg
CQY52	4b	LED	RPY20	4b	Ph	1N5738B	1b	Vrg
CQY53	4b	LED	RPY33	4b	Ph	1N5739B	1b	Vrg
CQY54	4b	LED	RPY55	4b	Ph	1N5740B	1b	Vrg
CQY61	4b	LED	RPY58A	4b	Ph	1N5741B	1b	Vrg
OA47	1b	GB	RPY71	4b	Ph	1N5742B	1b	Vrg
OA90	1b	PC	RPY76A	4b	I	1N5743B	1b	Vrg
OA91	1b	PC	RPY82	4b	Ph	1N5744B	1b	Vrg
OA95	1b	PC	RPY84	4b	Ph	1N5745B	1b	Vrg
OA200	1b	AD	RPY85	4b	Ph	1N5746B	1b	Vrg
OA202	1b	AD	1N821	1b	Vrf	1N5747B	1b	Vrg
ORP10	4b	I	1N823	1b	Vrf	1N5748B	1b	Vrg
ORP13	4b	I	1N825	1b	Vrf	1N5749B	1b	Vrg
ORP23	4b	Ph	1N827	1b	Vrf	1N5750B	1b	Vrg
ORP52	4b	Ph	1N829	1b	Vrf	1N5751B	1b	Vrg
ORP60	4b	Ph	1N914	1b	WD	1N5752B	1b	Vrg
ORP61	4b	Ph	1N914A	1b	WD	1N5753B	1b	Vrg
ORP62	4b	Ph	1N916	1b	WD	1N5754B	1b	Vrg
ORP66	4b	Ph	1N916A	1b	WD	1N5755B	1b	Vrg
ORP68	4b	Ph	1N916B	1b	WD	1N5756B	1b	Vrg
ORP69	4b	Ph	1N4009	1b	WD	1N5757B	1b	Vrg
ORP90	4b	Ph	1N4148	1b	WD	2N918	3	HF
OSB9110	1a	St	1N4150	1b	WD	2N929	2	LF
OSB9210	1a	St	1N4151	1b	WD	2N930	2	LF
OSB9310	1a	St	1N4154	1b	WD	2N1302	3	Sw
OSB9410	1a	St	1N4446	1b	WD	2N1303	3	Sw
OSM9110	1a	St	1N4448	1b	WD	2N1304	3	Sw
OSM9210	1a	St	1N5729B	1b	Vrg	2N1305	3	Sw
OSM9310	1a	St	1N5730B	1b	Vrg	2N1306	3	Sw
OSM9410	1a	St	1N5731B	1b	Vrg	2N1307	3	Sw
OSS9110	1a	St	1N5732B	1b	Vrg	2N1308	3	Sw

11/11/75
 11/11/75
 11/11/75
 11/11/75
 11/11/75

AD = Silicon alloyed diodes
 GB = Germanium gold bonded diodes
 HF = High frequency transistors
 I = Infrared devices
 LED = Light emitting diodes
 LF = Low frequency transistors
 PC = Germanium point contact diodes

Ph = Photoconductive devices
 St = Rectifier stacks
 Sw = Switching transistors
 Vrf = Voltage reference diodes
 Vrg = Voltage regulator diodes
 WD = Silicon whiskerless diodes

INDEX

Type No.	Part	Section	Type No.	Part	Section	Type No.	Part	Section
2N1309	3	Sw	2N3632	4a	Tr	56233	1a	A
2N1613	3	HF	2N3819	4a	FET	56234	1a	A
2N1711	3	HF	2N3823	4a	FET	56239	2	A
2N1893	3	HF	2N3866	4a	Tr	56245	2,3,4a	A
2N2218	3	Sw	2N3924	4a	Tr	56246	1a to 4a	A
2N2218A	3	Sw	2N3926	4a	Tr	56253	1a	DH
2N2219	3	Sw	2N3927	4a	Tr	56256	1a	DH
2N2219A	3	Sw	2N3966	4a	FET	56261	2	A
2N2221	3	Sw	2N4036	3	Sw	56262A	1a	A
2N2221A	3	Sw	2N4091	4a	FET	56263	1a to 4a	A
2N2222	3	Sw	2N4092	4a	FET	56264A	1a	A
2N2222A	3	Sw	2N4093	4a	FET	56268	1a	DH
2N2297	3	HF	2N4347	2	P	56271	1a	DH
2N2368	3	Sw	2N4391	4a	FET	56278	1a	DH
2N2369	3	Sw	2N4392	4a	FET	56280	1a	DH
2N2369A	3	Sw	2N4393	4a	FET	56290	1a	HE
2N2483	3	HF	2N4427	4a	Tr	56293	1a	HE
2N2484	3	HF	2N4856	4a	FET	56295	1a	A
2N2894	3	Sw	2N4857	4a	FET	56299	1a	A
2N2894A	3	Sw	2N4858	4a	FET	56309B	1a	A
2N2904	3	Sw	2N4859	4a	FET	56309R	1a	A
2N2904A	3	Sw	2N4860	4a	FET	56312	1a	DH
2N2905	3	Sw	2N4861	4a	FET	56313	1a	DH
2N2905A	3	Sw	61SV	4b	I	56314	1a	DH
2N2906	3	Sw	40809	2	LF	56315	1a	DH
2N2906A	3	Sw	40820	3	HF	56316	1a	A
2N2907	3	Sw	40835	3	HF	56318	1a	DH
2N2907A	3	Sw	56200	2,3,4a	A	56319	1a	DH
2N3055	2	P	56201	2	A	56326	2,3	A
2N3375	4a	Tr	56201c	2	A	56333	2,3	A
2N3442	2	P	56201d	2	A	56334	1a	DH
2N3553	4a	Tr	56203	2	A	56339	2	A
2N3570	3	HF	56218	2,3,4a	A	56348	1a	DH
2N3571	3	HF	56230	1a	HE	56349	1a	DH
2N3572	3	HF	56231	1a	HE	56350	1a	DH

A = Accessories
 DH = Diecast heatsinks
 FET = Field-effect transistors
 HE = Heatsink extrusions
 HF = High frequency transistors

I = Infrared devices
 LF = Low frequency transistors
 P = Low frequency power transistors
 Sw = Switching transistors
 Tr = Transmitting transistors

INDEX

Type No.	Part	Section
56351	2	A
56352	2	A
56353	2	A
56354	2	A

A = Accessories



General

Germanium small signal diodes (point contact)

(gold bonded)

Silicon small signal diodes (alloyed)

(whiskerless)

special diodes

voltage regulator diodes

voltage reference diodes

tuner diodes

Index

Electronic components and materials for professional, industrial and consumer uses from a world-wide Group of Companies

Argentina: FAPESA I.y.C., Av. Crovara 2550, Tel. 652-7438/7478, BUENOS AIRES.
Australia: Philips Industries Ltd., Elcoma Division, 67 Mars Road, Tel. 42 1261, LANE COVE, 2066, N.S.W.
Austria: Österreichische Philips, Bauelemente Industrie G.m.b.H., Zieglergasse 6, Tel. 93 26 11, A-1072 WIEN.
Belgium: M.B.L.E., 80, rue des Deux Gares, Tel. 523 00 00, B-1070 BRUXELLES.
Brazil: IBRAPE S.A., Av. Paulista 2073-S/Loja, Tel. 278-7144, SAO PAULO, SP.
Canada: Philips Electron Devices, 116 Vanderhoof Ave., Tel. 425-5161, TORONTO 17, Ontario.
Chile: Philips Chilena S.A., Av. Santa Maria 0760, Tel. 39-40 01, SANTIAGO.
Colombia: SADAPE S.A., Calle 19, No. 5-51, Tel. 422-175, BOGOTA D.E. 1.
Denmark: Miniwatt A/S, Emdrupvej 115A, Tel. (01) 69 16 22, DK-2400 KØBENHAVN NV.
Finland: Oy Philips Ab, Elcoma Division, Kaivokatu 8, Tel. 1 72 71, SF-00100 HELSINKI 10.
France: R.T.C., La Radiotechnique-Compelec, 130 Avenue Ledru Rollin, Tel. 355-44-99, F-75540 PARIS 11.
Germany: Valvo, U.B. Bauelemente der Philips G.m.b.H., Valvo Haus, Burchardstrasse 19, Tel. (040) 3296-1, D-2 HAMBURG 1.
Greece: Philips S.A. Hellénique, Elcoma Division, 52, Av. Syngrou, Tel. 915 311, ATHENS.
Hong Kong: Philips Hong Kong Ltd., Components Dept., 11th Fl., Din Wai Ind. Bldg., 49 Hoi Yuen Rd, Tel. K-42 72 32, KWUNTONG.
India: INBELEC Div. of Philips India Ltd., Band Box House, 254-D, Dr. Annie Besant Rd, Tel. 457 311-5, Prabhadevi, BOMBAY-25-DD.
Indonesia: P.T. Philips-Ralin Electronics, Elcoma Division, 'TIMAH' Building, Jl. Jen. Gatot Subroto, Tel. 44 163, JAKARTA.
Ireland: Philips Electrical (Ireland) Ltd., Newstead, Clonskeagh, Tel. 69 33 55, DUBLIN 14.
Italy: Philips S.p.A., Sezione Elcoma, Piazza IV Novembre 3, Tel. 2-6994, I-20124 MILANO.
Japan: NIHON PHILIPS, 32nd Fl., World Trade Center Bldg., 5, 3-chome, Shiba Hamamatsu-cho, Minato-ku, Tel. 03-435-5268, TOKYO.
Korea: Philips Korea Ltd., Philips House, 260-199 Itaewon-dong, Yongsan ku, Tel. 73-7222, C.P.O. Box 3680, SEOUL.
Mexico: Electrónica S.A. de C.V., Varsovia No. 36, Tel. 5-33-11-80, MEXICO 6, D.F.
Netherlands: Philips Nederland B.V., Afd. Elonco, Boschdijk 525, Tel. (040) 79 33 33, NL-4510 EINDHOVEN.
New Zealand: EDAC Ltd., 70-72 Kingsford Smith Street, Tel. 873 159, WELLINGTON.
Norway: Electronica A.S., Vitaminveien 11, Tel. (02) 15 05 90, P.O. Box 29, Grefsen, OSLO 4.
Peru: CADESA, Jr. Ito, No. 216, Apartado 10132, Tel. 27 73 17, LIMA.
Philippines: ELDAC, Philips Industrial Dev. Inc., 2246 Pasong Tamo, Tel. 86-89-51 to 59, MAKATI-RIZAL.
Portugal: Philips Portuguesa S.A.R.L., Av. Eng. Duharte Pacheco 6, Tel. 68 31 21, LISBOA 1.
Singapore: Philips Singapore Private Ltd., Elcoma Div., P.O. Box 340, Toa Payoh Central P.O., Lorong 1, Toa Payoh, Tel. 53 88 11, SINGAPORE 12.
South Africa: EDAC (Pty.) Ltd., South Park Lane, New Doornfontein, Tel. 24/6701-2, JOHANNESBURG.
Spain: COPRESA S.A., Balmes 22, Tel. 329 63 12, BARCELONA 7.
Sweden: ELCOMA A.B., Lidingsvägen 50, Tel. 08/67 97 80, S-10 250 STOCKHOLM 27.
Switzerland: Philips A.G., Edenstrasse 20, Tel. 01/44 22 11, CH-8027 ZUERICH.
Taiwan: Philips Taiwan Ltd., 3rd Fl., San Min Building, 57-1, Chung Shan N. Rd, Section 2, P.O. Box 22978, Tel. 5513101-5, TAIPEI.
Turkey: Türk Philips Ticaret A.S., EMET Department, Gümüssuyu Cad. 78-80, Tel. 45.32.50, Beyoğlu, ISTANBUL.
United Kingdom: Mullard Ltd., Mullard House, Torrington Place, Tel. 01-580 6633, LONDON WC1E 7HD.
United States: North American Philips Electronic Component Corp., 230, Duffy Avenue, Tel. (516) 931-6200, HICKSVILLE, N.Y. 11802.
Uruguay: Luzilectron S.A., Rondeau 1567, piso 5, Tel. 9 43 21, MONTEVIDEO.
Venezuela: Industrias Venezolanas Philips S.A., Elcoma Dept., Av. Principal de los Ruices, Edif. Centro Colgate, Apdo 1167, Tel. 36.05.11, CARACAS.

©N.V. Philips' Gloeilampfabrieken